

GLORY STAR - G3



KTA19-G3/G4 零件图册

KTA19-G3/G4 PARTS CATALOG

零件号: 3166155-00

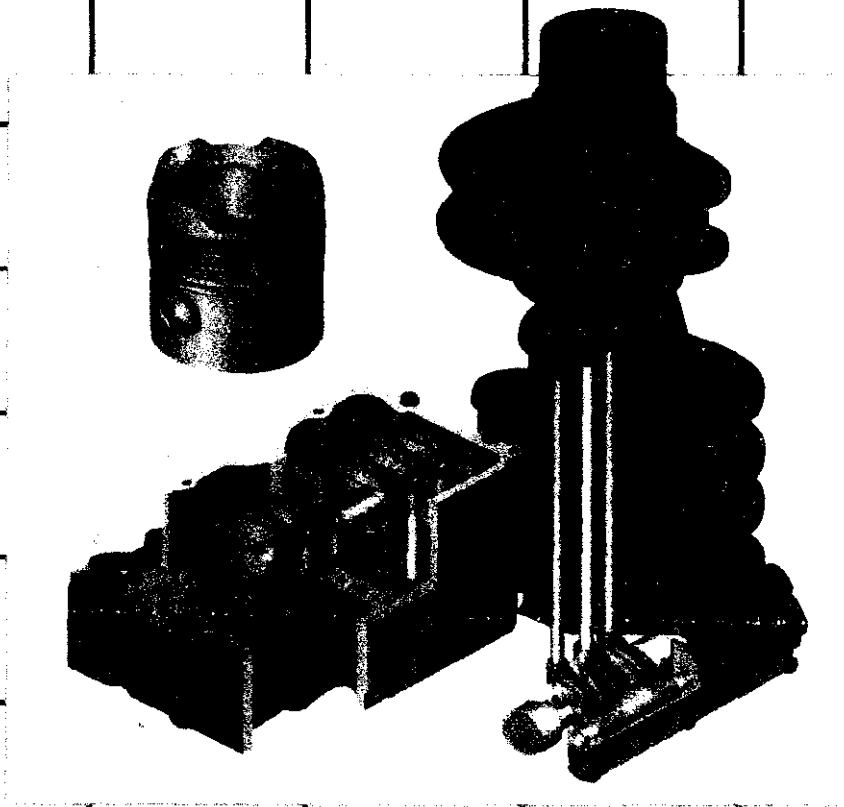

重庆康明斯发动机有限公司
CHONGQING CUMMINS ENGINE COMPANY Ltd.

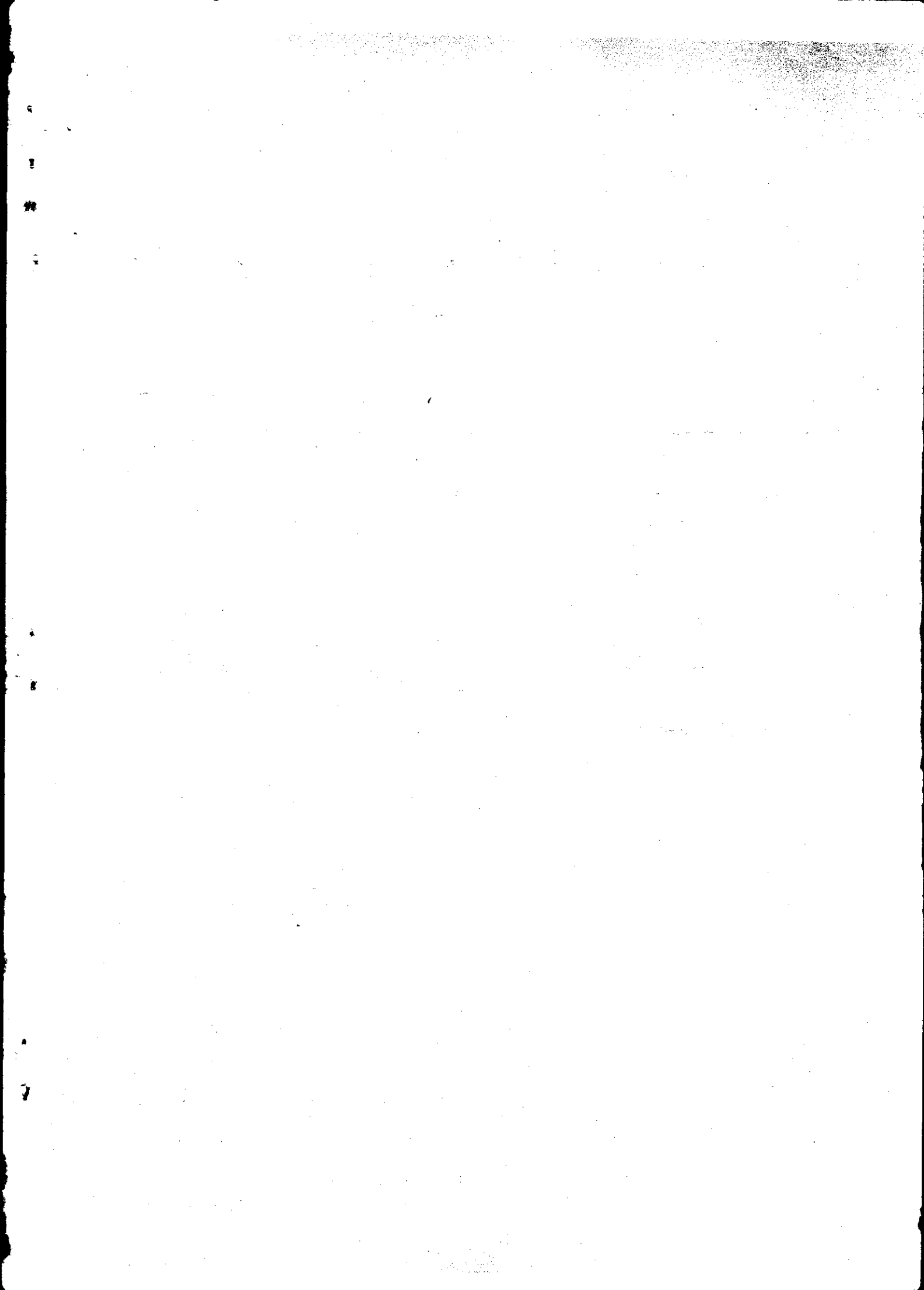

重庆康明斯发动零件图册
适用机型 KTA19-G3 及 KTA19-G4

使用 说 明

本图册是根据公司开发发电机组需要编制的K系列G3/G4驱动发动机零件图册,它以直观的形式显现出了发动机的易损零件和一般零件。是用户选购零部件指导性的资料。

随着发动机的不断改进,图册零件号 and 实际使用零件号可能有出入,请用户在选购零件时尽可能提供以下情况:

- 一、发动机铭牌或合格证上的机型和生产指令号(S.O)、以及发动机出厂序号。
- 二、写明图册中的图册零件号(最好注明页次)。

我公司可根据用户提供的以上资料,查到对应的实际使用零件号。用户在使用此图过程中,如有问题,可随时向我公司提出,我们会尽快的作出答复。

重庆康明斯发动机有限公司

2001年6月

INSTRUCTION

The catalog is compiled for the K series engine, which used on generator. It's very easy for you to find what kinds of engine parts to be ordered and replaced, since K series engine has a high communality, the catalog is guideline for our customers to order the parts he/she wants.

With improvements on the engines were producing, the part no. in the catalog may be different from that in present production.

The following information will be supplied when you order the parts.

*Engine model and shop order No.(s.o.) on the nameplate of your engine or the certificate, and the series no. of engine.

**The exact part no. in the catalog (it's better to put down the page No. in the catalog).

We can find out the present part no. upon your correct information, then we'll take prompt action to resolve your problems.

chongqing cummins engine company ltd.

目 录 ABLE OF CONTENTS

标题	TITLE	页次 PAGE NO
空气滤清器	AIR CLEANER	1
正时轮盘	TIMING DISK	3
发电机皮带轮	ALTERNATOR PULLEY	5
气缸体	CYLINDER BLOCK	7, 9
中间齿轮	IDLER GEAR	11
曲轴和主轴瓦	CRANKSHAFT & MAIN BEARINGS	13
摇臂	ROCKER LEVER	15
凸轮轴从动件(G3)	CAM FOLLOWER	17
凸轮轴从动件(G4)	CAM FOLLOWER	19
机油管	OIL MANIFOLD	21
HVT机油供油管(G3)	HVT OIL SUPPLY PLUMBING	22
机油泵	LUB OIL PUMP	23
曲轴箱通风器	BREATHER LOCATION	25
空气阻力指示器	RESTRICTION INDICATOR	27
减振器	VIBRATION DAMPER,	28
油压报警开关	LOW OIL PRESSURE SWITCH	29
水温报警开关	COOLANT TEMPERATURE SWITCH	30
发电机安装	ALTERNATOR MOUNTING	31
发电机	ALTERNATOR	32
齿轮室盖	FRONT ENGINE SUPPORT	33, 35
齿轮室盖安装	GEAR COVER MOUNTING	37
磁力开关	MAGNETIC SWITCH	39
风扇轮毂	FAN HUB	41, 43
燃油滤清器	FUEL FILTER	45
燃油滤清器管路	FUEL FILTER PLUMBING	47
飞轮壳	FLYWHEEL HOUSING	49
电磁传感器	MAGNETIC PICKUP	51
加机油口	OIL FILL LOCATION	52
控制器	CUMMINS EFC GOVERNOR	53
附件驱动	FUEL PUMP DRIVE	54
燃油泵	FUEL PUMP	55
燃油管路	FUEL TUBING	57, 59
飞轮	FLYWHEEL	61
液压泵法兰盖	COVE PLATE	62
水箱连接	RADIATOR CONNECTION	63
进气管	INTAKE MANIFOLD	65

目 录 ABLE OF CONTENTS

标题	TITLE	页次 PAGE NO
进气管安装	INTAKE MANIFOLD MOUNTING	67
节温器壳	THERMOSTAT HOUSING ASSY	69
机油滤清器	LUB OIL FILTER	71
机油滤清器连接件	OIL FILTER CONNECTION	73
机油尺	OIL LEVEL GAUGE	74
手孔盖	HAND HOLE COVERS	75
机油旁通滤清器	BYPASS OIL FILTER	76
机油旁通滤清器管路	OIL BYPASS FILTER PLUMBING	77
机油盘	OIL PAN	79, 81
活塞和连杆	PISTON AND CONNROD	83
凸轮轴和齿轮(G3)	CAMSHAFT AND GEAR	85
凸轮轴和齿轮(G4)	CAMSHAFT AND GEAR	86
中冷器芯	AFTERCOOLER CORE	87
气缸盖	CYLINDER HAND	89
气缸盖安装	CYLINDER HAND MOUNTING	91
喷油器(G3)	INJECTOR	93
喷油器(G4)	INJECTOR	95
增压器(G3)	TURBOCHARGER	97
增压器(G4)	TURBOCHARGER	99
机油控制阀(STC)(G4)	OIL CONTROL VALVE	101, 103
机油控制阀(HVT)(G3)	OIL CONTROL VALVE	105
摇臂室	ROCKER HOUSING	107
起动机	STARING MOTOR	108
排气管	EXHAUST MANIFOLD	109
增压器安装	TURBO MOUNTING	111
机油冷却器	OIL COOLER	113
出水管接头	OIL COOLER CONNECTION	115
水滤器	CORROSION RESISTOR	116
进水管接头	WATER INLET CONNECTION	117
输水管	WATER MANIFOLD	118
出水接头	WATER OUTLET CONNECTION	119
水泵	WATER PUMP	121, 123
排气管接头	EXHAUST BLBOW	125
排气波纹管	FLEX EXHAUST TUBING	126



表-01

S/N

Item

空气滤清器

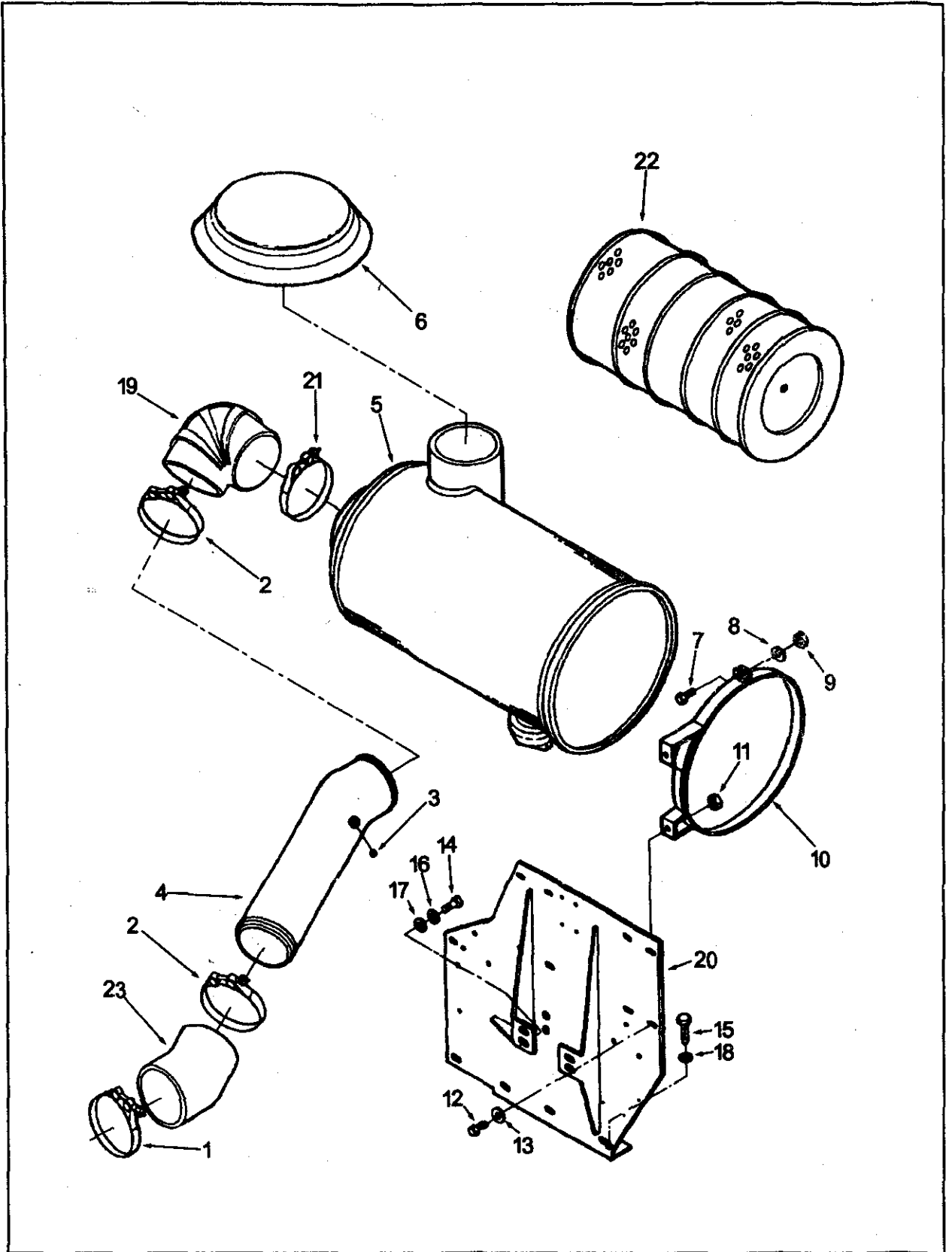
56/ly AC 4040

级别	零件号	图上 标号	零件名称		数量	备注
			中文	英文		
02	125741	1	抱箍	CLAMP,T BOLT	1	
02	140313	2	抱箍	CLAMP,T BOLT	2	
02	3001870	4	进气管	TUBE,AIR INLET	1	
02	3017002		空气滤清器	CLEANER,AIR	1	
	(3018042)	22	空气滤清器芯	ELEMENT,AIR CLEANER	1	
	(3165205)	5	空气滤清器壳	HOUSING,AIR CLEANER	1	
02	3017003	6	空滤器帽	CAP,AIR CLEANER	1	
02	3022323		空滤器安装	MTG,AIR CLEANER	1	
03	103023	12	六角螺栓	SCREW,HEXAGON HEAD CAP	4	
03	3000082	13	平垫圈	WASHER,PLAIN	4	
03	S 217	11	六角厚螺母	NUT,HEAVY HEXAGON	4	
02	3022325		空滤器支架安装	MTG,SUPPORT	1	
03	108330	16	平垫圈	WASHER,PLAIN	4	
03	203310	18	平垫圈	WASHER,PLAIN	2	
03	S 109	14	六角螺栓	SCREW,HEXAGON HEAD CAP	4	
03	S 145	15	六角螺栓	SCREW,HEXAGON HEAD	2	
02	3025458	3	管塞	PLUG,PIPE	1	
02	3030514	19	软管	HOSE,ELBOW	1	
02	3030782	23	软管	HOSE,ELBOW	1	
02	3034735	20	空滤器支架	BRACKET,AIR CLEANER	1	
02	3175623	21	抱箍	CLMP,T BOLT	1	
02	4067603		箍带安装	MTG,STRAPS	1	
03	69832	9	六角螺母	NUT,REGULER HEXAGON	2	
03	197221	10	空滤器箍带	STRAP,AIR.CLEANER	2	
03	S 111	7	六角螺栓	SCREW,HEXAGON HEAD	2	
03	S 605	8	弹簧垫圈	WASHER,LOCK	2	

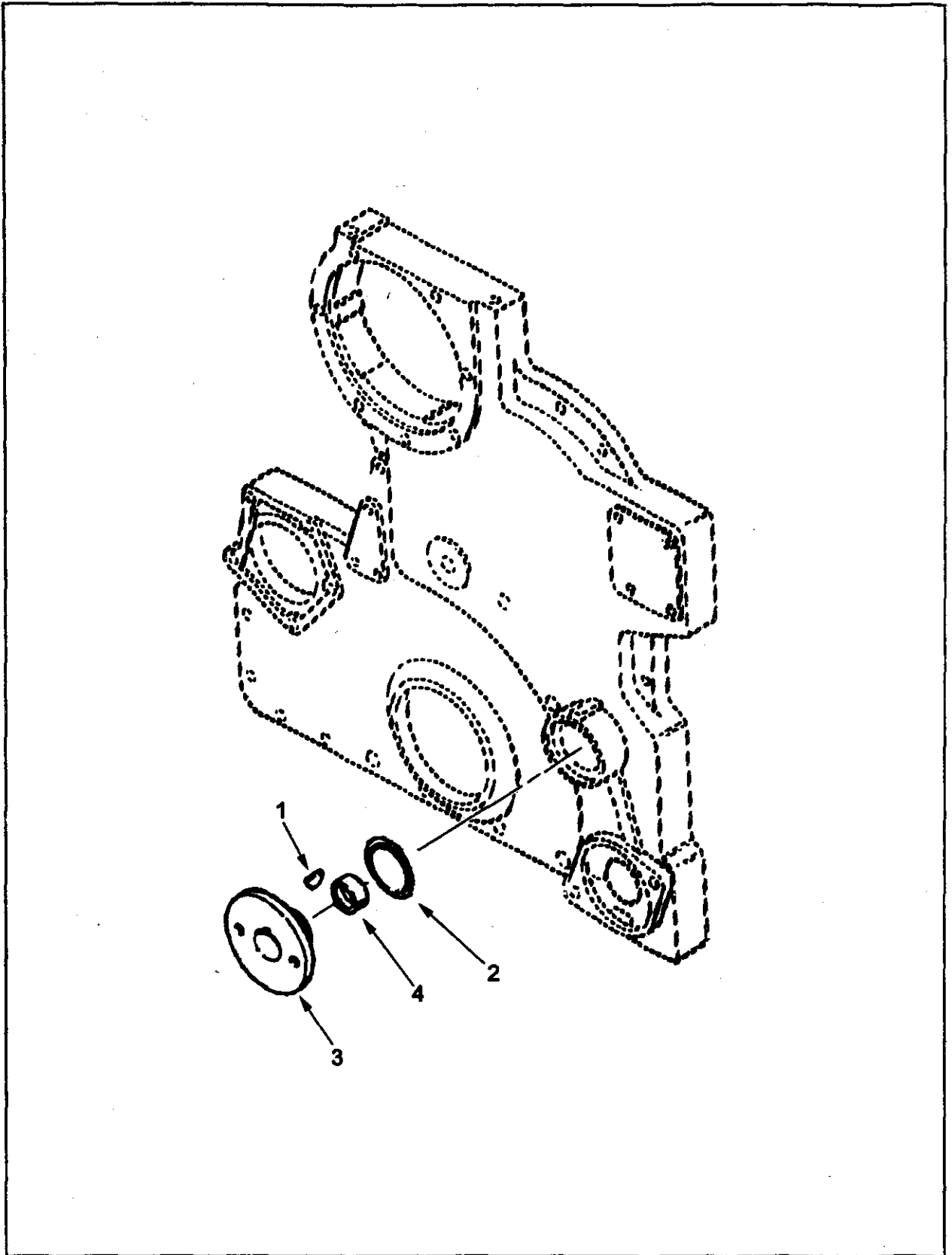

级别	零件号	图上 标号	零件名称		数量	备注
			中文	英文		
02	3007111		正时盘轮毂	HUB,TIMING	1	
03	3007201	3	正时盘轮毂	HUB,TIMING	1	
03	190397	4	耐磨套	SLEEVE,WEAR	1	
02	MP 4986		附件驱动皮带轮安装	PULLEY,ACCESSORY MTG	1	
03	3200287	2	键槽密封件	SEAL,KEYWAY	1	
03	S 316	1	半园键	KEY,PLAIN WOODRUFF	1	

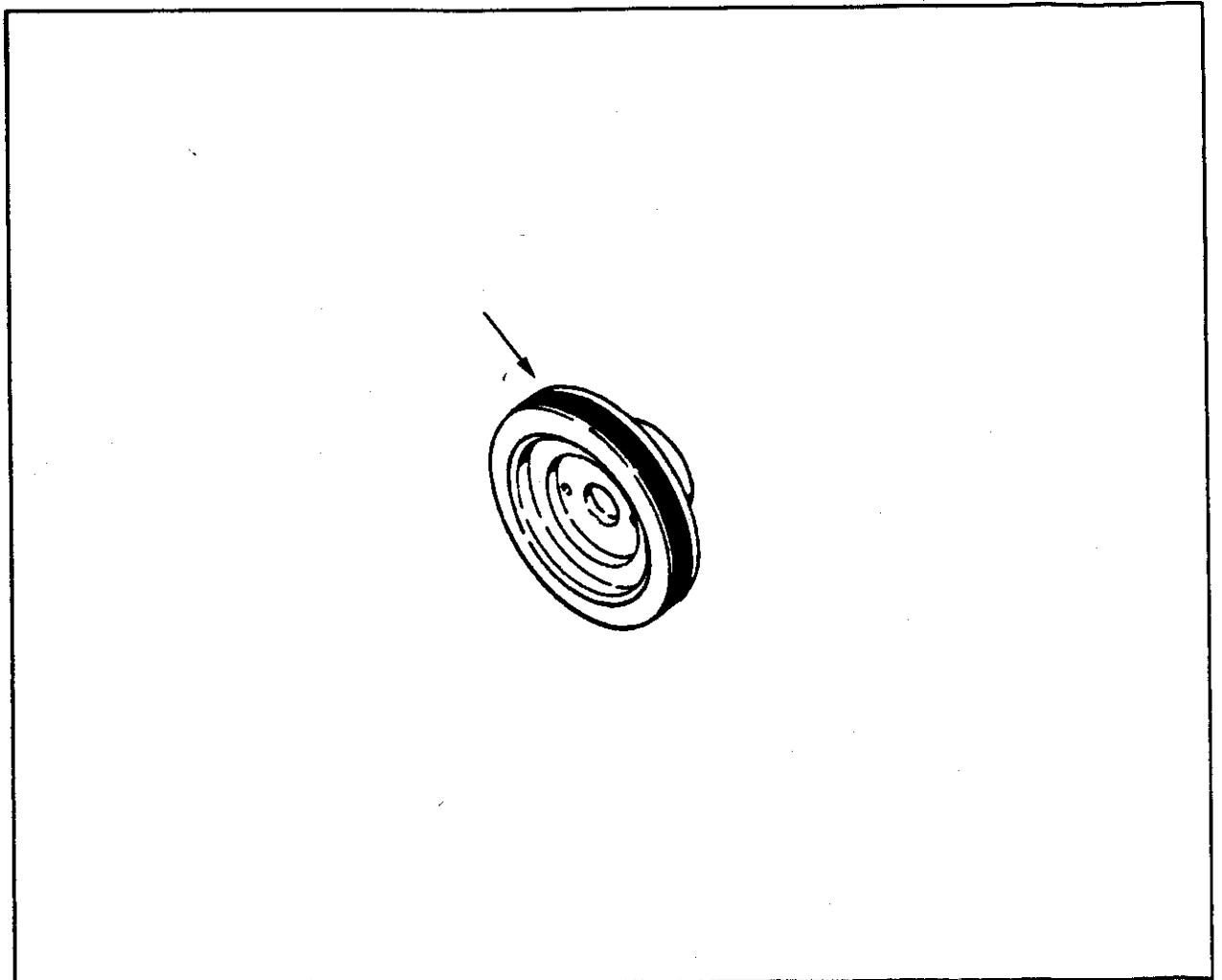

级别	零件号	图上 标号	零件名称		数量	备注
			中文	英文		
02	3002331	1	发电机皮带轮	PULLEY,ATLERNATOR	1	

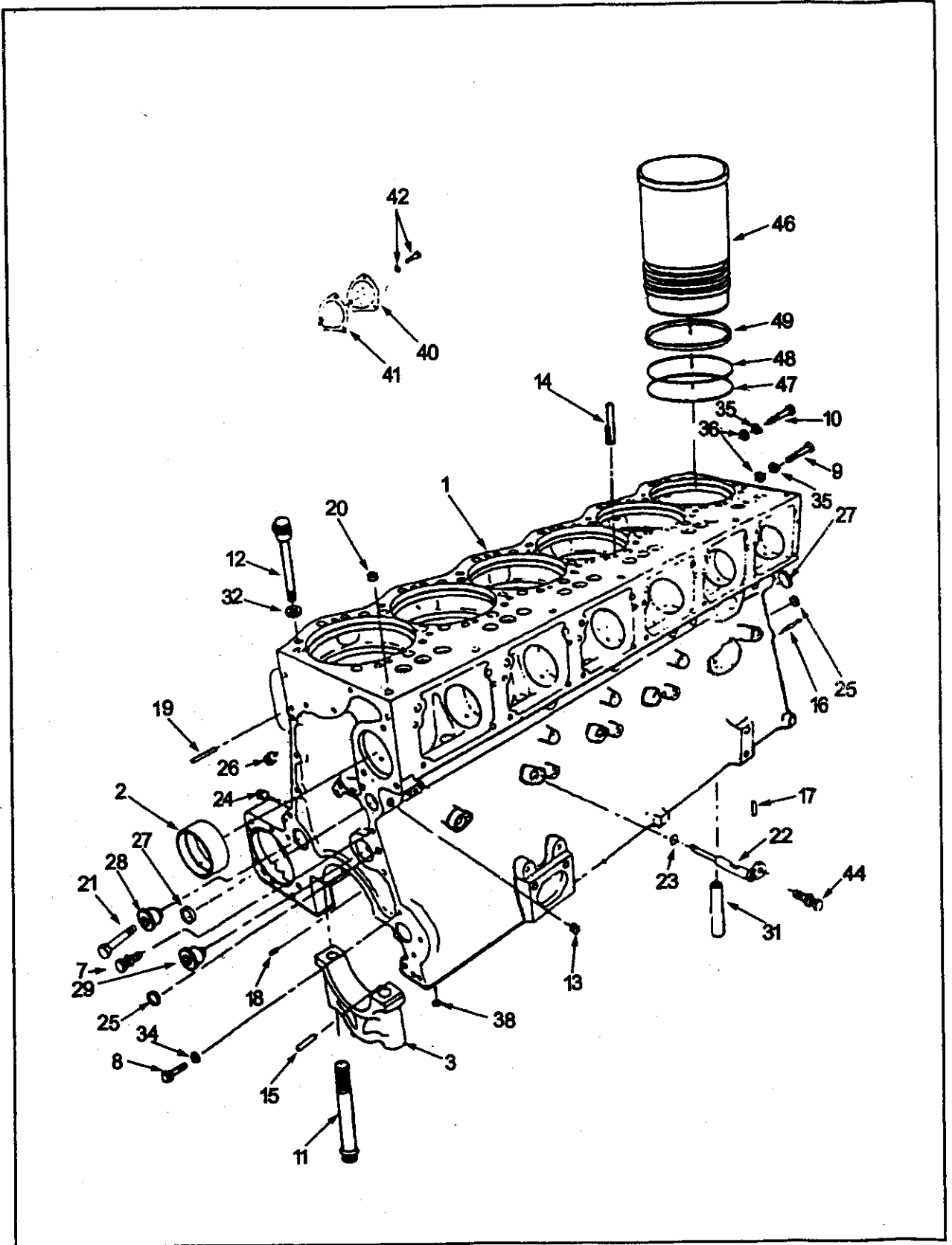

气 缸 体

级 别	零 件 号	图 上 标 号	零 件 名 称		数 量	备 注
			中 文	英 文		
02	3044517		气缸体总成	BLOCK,CYLINDER	1	
03	147416	25	碗形塞	PLUG,EXPANSION	2	
03	175830	27	碗形塞	PLUG,EXPANSION	2	
03	3007632	20	碗形塞	PLUG,EXPANSION	8	
03	3044516		气缸体分总成	BLOCK,CYLINDER	1	
04	67211	17	后主轴承定位销	DOWEL,REAR MAIN	2	
04	124921	18	定位销	DOWEL	2	
04	205021	3	主轴承盖	CAP,MAIN BEARING	4	
04	205022	3	主轴承盖	CAP,MAIN BEARING	1	
04	205023	3	主轴承盖	CAP,MAIN BEARING	1	
04	205075	3	主轴承盖	CAP,MAIN BEARING	1	
04	205298	31	机油输油管	TUBE,LUB OIL TRANSFER	1	
04	3002834	2	衬套	BUSHING	7	
04	3025482	11	十二角螺栓	SCREW,TWELVE POINT CAP	14	
04	3044515	1	气缸体	BLOCK,CYLINDER	1	
02	3028438		气缸体安装	BLOCK,CYLINDER MTG	1	
03	68445	14	带槽圆柱销	PIN,GROOVE	12	
03	3008470	26	管塞	PLUG,PIPE	1	
03	3025458	24	管塞	PLUG,PIPE	1	
03	3025460	13	管塞	PLUG,PIPE	2	
02	3028434		气缸套组件	KIT,LINER	6	
03	3011076	48	O型密封圈	SEAL,O RING	1	
03	3014668	47	O型密封圈	SEAL,O RING	1	
03	3081489	49	缝隙密封圈	SEAL,OIL	1	
03	3202240	46	气缸套	KIT,LINER	1	
02	3200936		活塞冷却喷嘴	NOZZLE,PISTON COO	6	
03	3007517	22	活塞冷却喷嘴	NOZZLE,PISTON COO	1	
	(3015067)	23	O型密封圈	SEAL,O RING	1	
03	3033822	44	带垫圈螺栓	SCREW,CAPTIVE WAS	1	
02	3013962		气缸盖安装	HEAD,CYLINDER MTG	6	
03	205059	32	平垫圈	WASHER,PLAIN	6	
03	3032633	12	十二角螺栓	SCREW,TWELVE POINT CAP	6	
03	3086362		丁字压板	CROSSHEAD,VALVE	2	

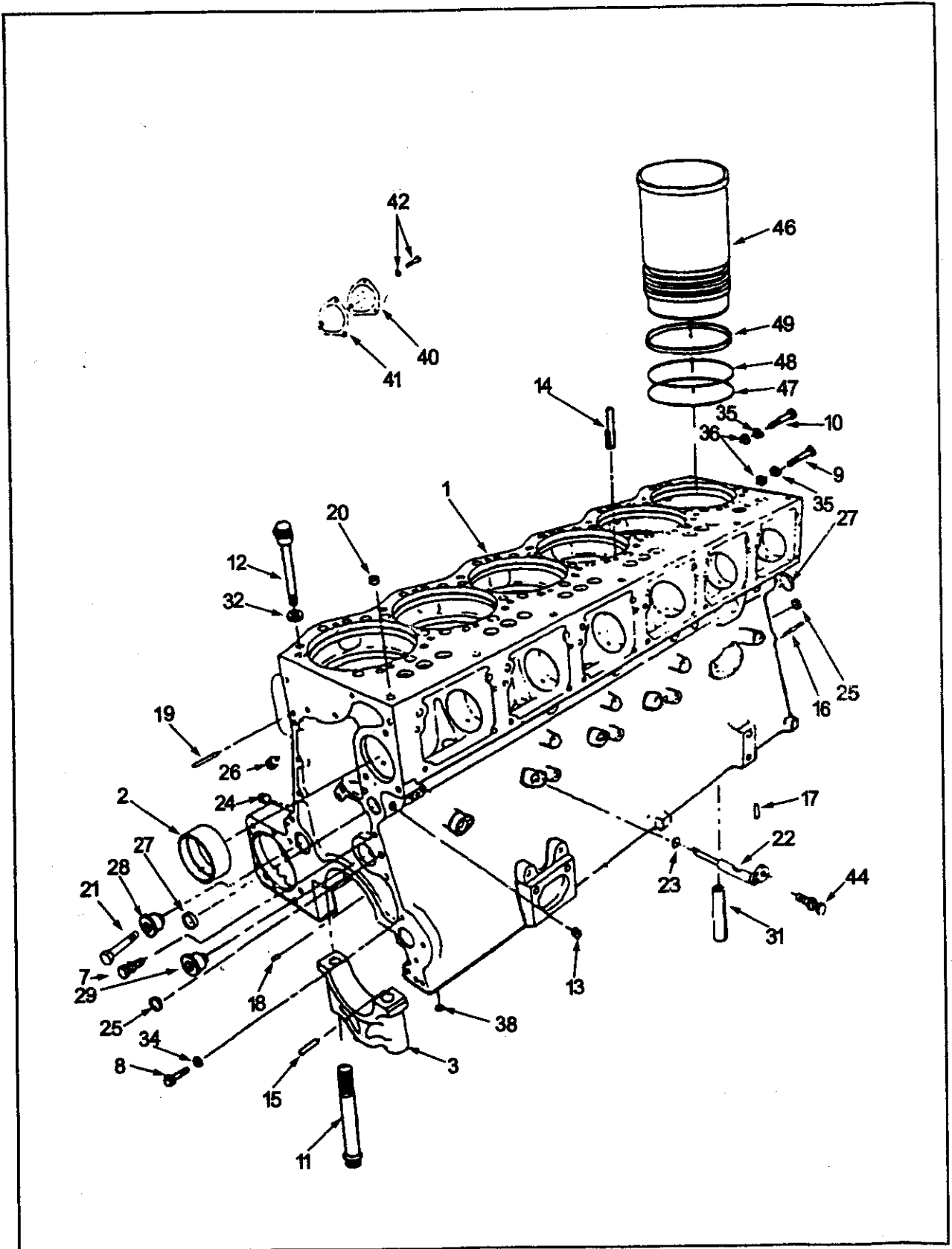

级 别	零 件 号	图 上 标 号	零 件 名 称		数 量	备 注
			中 文	英 文		
02	3007803		惰齿轮安装	IDLER,GEAR MTG	2	
03	130083		止推轴承	BEARING,THRUST	2	
03	207527	21	十二角螺栓	SCREW,TWELVE POINT	1	
03	3200772		平垫圈	WASHER,PLAIN	1	
03	3202114	28	惰轮轴	SHAFT,IDLER	1	
02	3028968		飞轮壳安装	HOUSING,FLYWHEEL MTG	1	
03	9226	16	飞轮壳定位销	DOWEL,FLYWEEL HOUSING	2	
03	172648		矩形圈	SEAL,RECTANGULAR RING	14	
03	3096260		矩形密封圈	SEAL,RECTANGULAR RING	1	
03	S 103	A 10	六角螺栓	SCREW,HEXAGON HEAD	10	
03	S 144	9	六角螺栓	SCREW,HEXAGON HEAD	2	
03	S 603	35	弹簧垫圈	WASHER,LOCK	12	
02	3016717		正时齿轮室板安装	MTG,GEAR COVER	1	
03	70645	15	主定位销	DOWEL PIN	1	
03	102957	19	定位销	DOWEL,DIAMOND	1	
03	3014766	7	带垫螺栓	SCREW,CAPTIVE WASHER CAP	12	
03	3410141		衬垫	GASKET,COVER PIAT	1	
02	207373	40	凸轮轴端盖	COVER,CAMSHAFT	1	
02	MP 4981		凸轮轴盖安装	WASHER,LOCK	1	
03	3014766	42	带垫螺栓	SCREW,CAPTIVE WASHER CAP	3	
03	3040722	41	凸轮轴盖衬垫	GASKET,CAMSHAFT COVER	1	

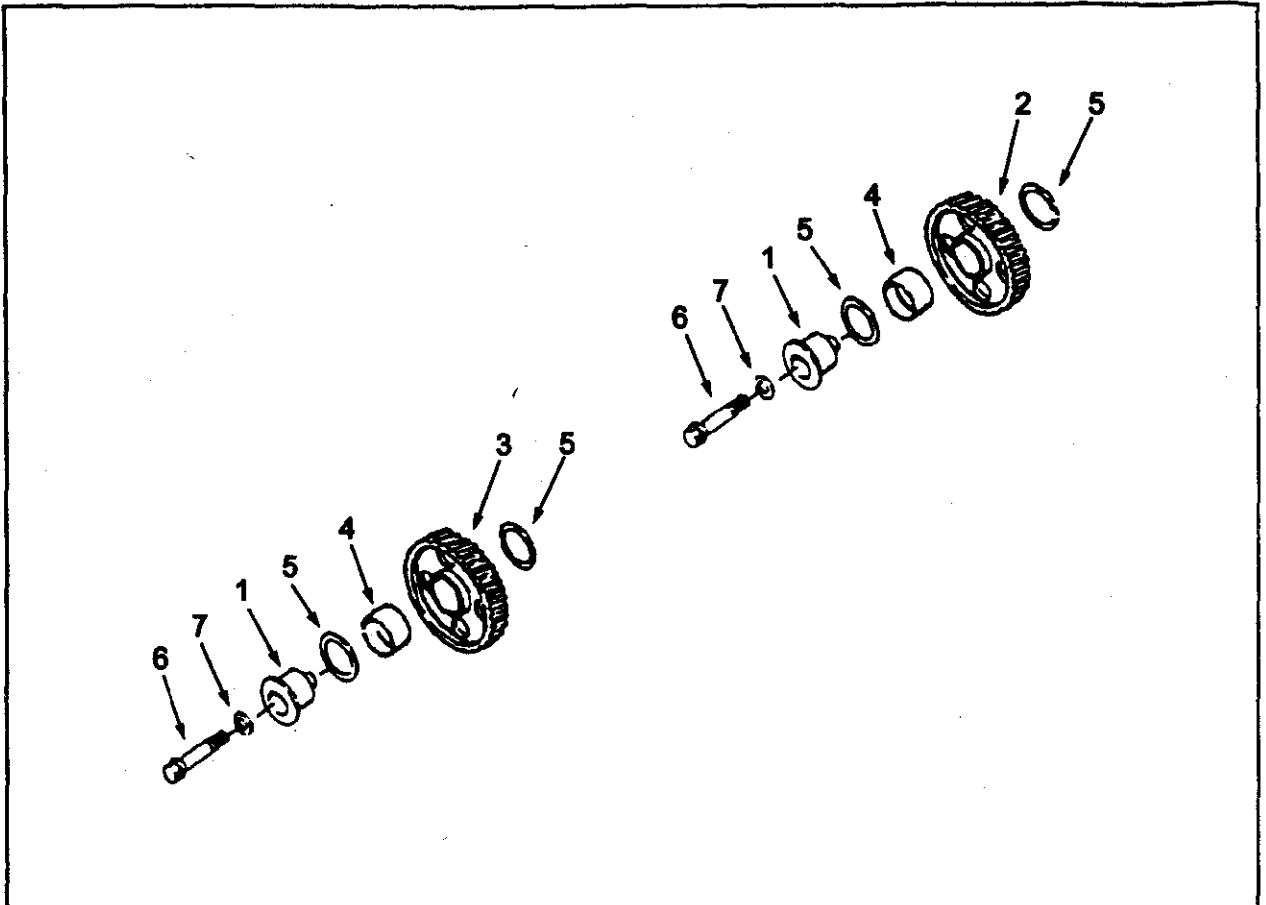

级别	零件号	图上 标号	零件名称		数量	备注
			中文	英文		
02	3004684		凸轮轴中间齿轮	GEAR,BUSHING CAM IDLER	1	
	(3004599)	2	凸轮轴中间齿轮	GEAR,IDLER	1	
	(3004686)	4	衬套	BUSHING	1	
02	3004685		水泵中间齿轮	GEAR,BUSHING WTR IDLER	1	
	(3004680)	3	水泵中间齿轮	GEAR,IDLER	1	
	(3004686)	4	衬套	BUSHING	1	
02	3007803		惰齿轮安装	IDLER,GEAR MTG	2	
03	130083	5	止推轴承	BEARING,THRUST	2	
03	207527	6	十二角螺栓	SCREW,TWELVE POINT	1	
03	3200772	7	平垫圈	WASHER,PLAIN	1	
03	3202114	1	惰轮轴	SHAFT,IDLER	1	

曲轴和主轴瓦

级别	零件号	图上 标号	零件名称		数量	备注
			中文	英文		
02	3418910		曲轴总成	CRANKSHAFT	1	
03	206904	3	半圆键	KEY,WOODRUFF	1	
03	207259	2	曲轴齿轮	GEAR,CRANKSHFT	1	
03	3418898	1	曲轴	CRANKSHAFT	1	
02	AR12270		主轴瓦组	SHELL,MAIN BEARIN	1	标准
03	205112	9	止推轴承	BEARING,THRUST	4	
03	205140	4	主轴承	BEARING,MAIN	5	第2,3,4,5,6上瓦
03	205150	5	主轴承	BEARING,MAIN	5	第2,3,4,5,6下瓦
03	205160	6	主轴承	BEARING,MAIN	2	第1,7下瓦
03	205170	7	主轴承	BEARING,MAIN	2	第1,7上瓦
02	AR12271		主轴瓦组	SHELL,MAIN BEARIN	1	加厚0.10英寸
03	205112	9	止推轴承	BEARING,THRUST	4	
03	205141	4	主轴承	BEARING,MAIN	5	第2,3,4,5,6上瓦
03	205151	5	主轴承	BEARING,MAIN	5	第2,3,4,5,6下瓦
03	205161	6	主轴承	BEARING,MAIN	2	第1,7下瓦
03	205171	7	主轴承	BEARING,MAIN	2	第1,7上瓦
02	AR12272		主轴瓦组	SHELL,MAIN BEARIN	1	加厚0.20英寸
03	205112	9	止推轴承	BEARING,THRUST	4	Standard
03	205142	4	主轴承	BEARING,MAIN	5	第2,3,4,5,6上瓦
03	205152	5	主轴承	BEARING,MAIN	5	第2,3,4,5,6下瓦
03	205162	6	主轴承	BEARING,MAIN	2	第1,7下瓦
03	205172	7	主轴承	BEARING,MAIN	2	第1,7上瓦
02	AR12273		主轴瓦组	SHELL,MAIN BEARIN	1	加厚0.30英寸
03	205112	9	止推轴承	BEARING,THRUST	4	
03	205143	4	主轴承	BEARING,MAIN	5	第2,3,4,5,6上瓦
03	205153	5	主轴承	BEARING,MAIN	5	第2,3,4,5,6下瓦
03	205163	6	主轴承	BEARING,MAIN	2	第1,7下瓦
03	205173	7	主轴承	BEARING,MAIN	2	第1,7上瓦
	3001196	9	止推轴承	BEARING,THRUST	4	加厚0.10英寸
	3001197	9	止推轴承	BEARING,THRUST	4	加厚0.20英寸

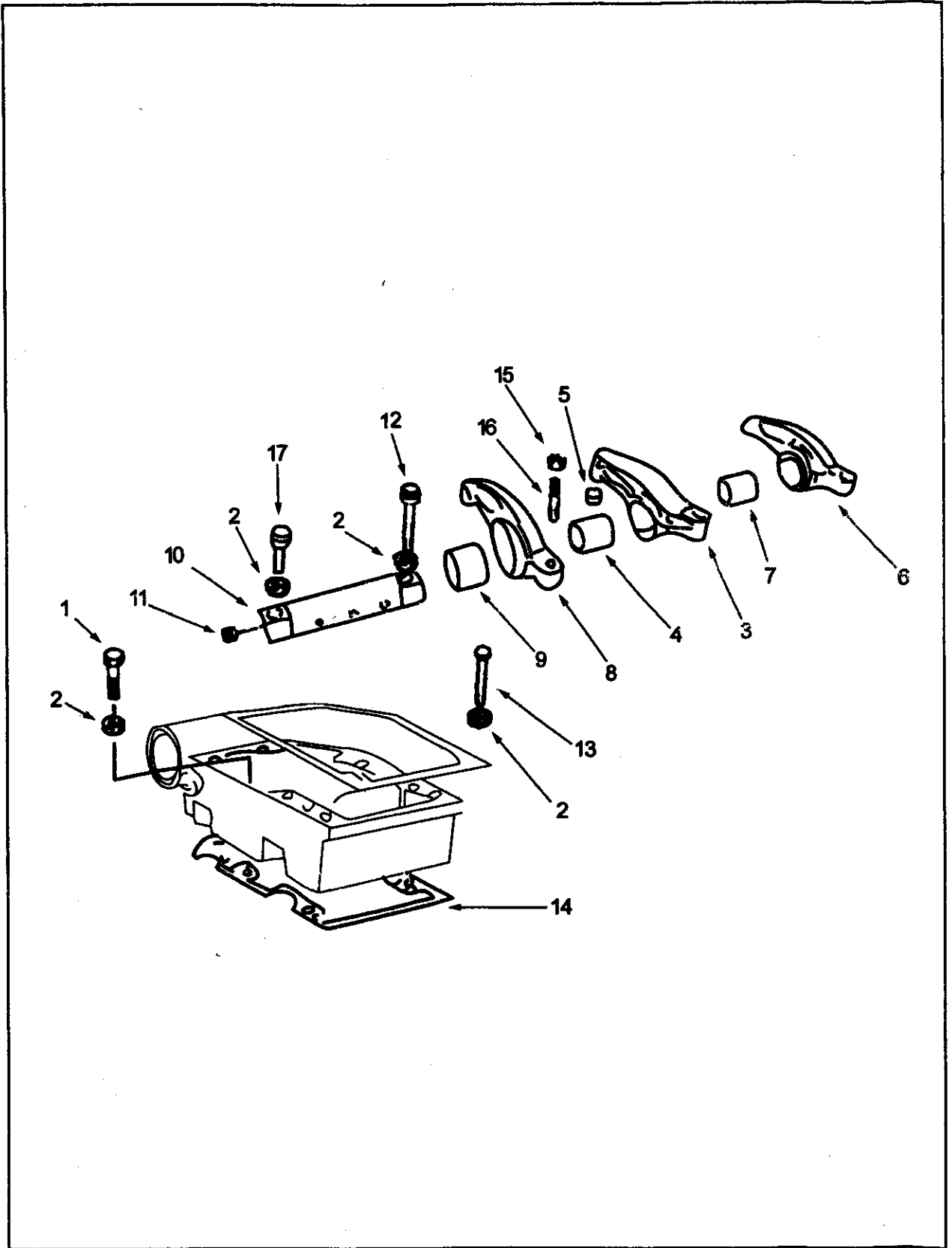

表一07

摇 臂

BP 4016、BP4026

级别	零件号	图上 标号	零件名称		数量	备注
			中文	英文		
02	3065810		摇臂总成	LEVER,ROCKER	6	
03	168306	16	开槽调节螺栓	SCREW,SLOTTED SET	3	
03	3053476		摇臂	LEVER,ROCKER	1	
04	207344	7	衬套	BUSHING	1	
04	208084		铆钉	RIVET	1	
04	3418857	6	摇臂	LEVER,ROCKER	1	
03	3053477		摇臂	LEVER,ROCKER	1	
04	207344	9	衬套	BUSHING	1	
04	208084		铆钉	RIVET	1	
04	3418859	8	摇臂	LEVER,ROCKER	1	
03	3053478		喷油摇臂	LEVER,ROCKER	1	
04	194037	5	摇臂凹头	SOCKET,ROCKER LEVER	1	
04	207226	4	衬套	BUSHING	1	
04	208084		铆钉	RIVET	1	
04	3418858	3	摇臂	LEVER,ROCKER	1	
03	3176773		摇臂轴	SHAFT,ROCKER LEVER	1	
04	203933	11	碗形塞	PLUG,EXPANSION	1	
04	3176875	10	摇臂轴	SHAFT,ROCKER LEVER	1	
03	S 212	15	六角螺母	NUT,REGULAR HEXAGON	3	
02	MP 5480		摇臂安装	LEVER,ROKER MTG	6	
03	205128	2	平垫圈	WASHER PLAIN	2	
03	205393	17	十二角螺栓	SCREW,TWELVE POINT CAP	1	
03	205394	12	十二角螺栓	SCREW,TWELVE POINT CAP	1	
02	MP 5479		摇臂室安装	HOUSING, ROCKER ARM MTG	6	
03	108602	13	六角螺栓	SCREW,HEXAGON HEAD	5	
03	205128	2	平垫圈	WASHER PLAIN	6	
03	3630839	14	摇臂室衬垫	GASKET,RKR LEVER HOUSING	1	
03	S 125	1	六角螺栓	SCREW,HEXAGON HEAD CAP	1	

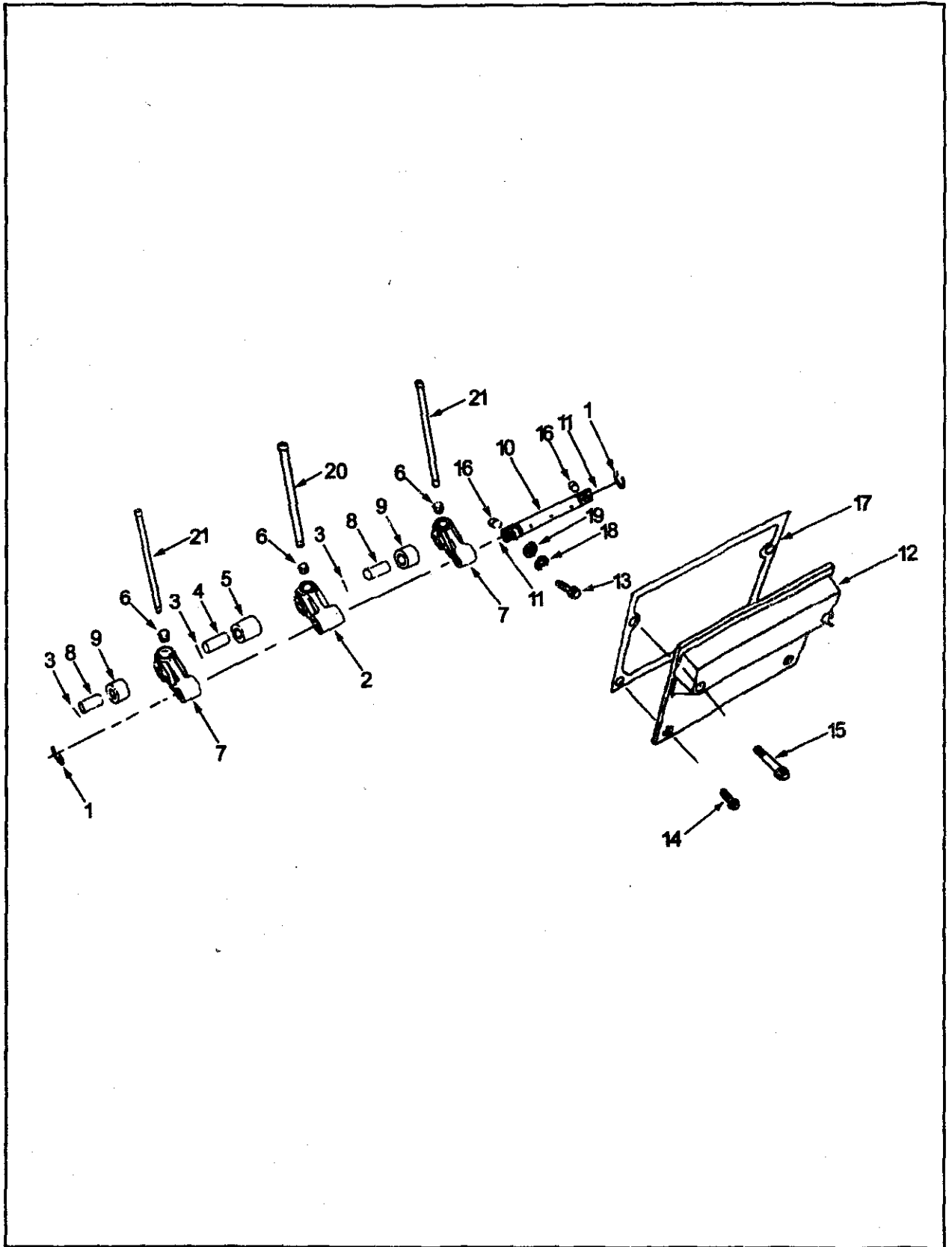

凸轮轴从动件 G3

级别	零件号	图上 标号	零件名称		数量	备注
			中文	英文		
02	AR10627 CE		凸轮轴从动件	FOLLOWER,CAMSHAFT	6	G3
03	205439	1	卡环	RING,RETAINING	2	
03	3039163 B		凸轮从动件	LEVER,CAM FOLLOWER	1	
04	205068	4	喷油凸轮从动件滚轮销	PIN,CAM FOLLOWER	1	
04	205438		滚轮锁紧钢丝	LOCKWIRE,CAM ROL	1	
04	213559	6	凸轮轴从动件凹头	SOCKET,CAM FOLLOW	1	
04	3016825	5	凸轮从动件滚轮	ROLLER,CAM FOLLOWER	1	
04	3655377	2	喷油凸轮从动件分总成	LEVER,CAM FOLLOWER	1	
03	3039164 B		凸轮从动件	LEVER,CAM FOLLOWER	2	
04	205071	8	气门凸轮从动件滚轮销	PIN,CAM FOLLOWER	1	
04	205438	3	滚轮锁紧钢丝	LOCKWIRE,CAM ROL	1	
04	213559	6	凸轮轴从动件凹头	SOCKET,CAM FOLLOW	1	
04	3016826	9	凸轮从动件滚轮	ROLLER,CAM FOLLOWER	1	
04	3655378	7	气门凸轮从动件分总成	LEVER,CAM FOLLOW	1	
03	AR10626		轴和管塞	SHAFT,CAM FOLLOWER	1	
04	205227	11	碗形塞	PLUG,EXPANSION	2	
04	205301	10	凸轮从动件轴	SHAFT,CAM FOLLOWER	1	
02	MP 4987		凸轮从动件安装	FOLLOWER,CAMSHAFT	6	
03	127362	19	平垫圈	WASHER,PLAIN	2	
03	3002886	13	凸轮从动件螺栓	SCREW,CAMFOLLOWER	2	
03	3002993	16	定位环	DOWEL,RING	2	
03	S 604	18	弹簧垫圈	WASHER,LOCK	2	
02	3628755	12	凸轮从动件盖	COVER CAMSHAFT	4	
02	MP 5297		凸轮从动件盖安装	COVER,CAM FOLLOWER	6	
03	127362	19	平垫圈	WASHER,PLAIN	4	
03	3010596	14	带垫圈螺栓	SCREW,CAPTIVE WAS	2	
03	3040721	17	凸轮从动件衬垫	GASKET,CAM FOL HOUSING	1	
03	S 126	15	六角螺栓	SCREW,HEXAGON HEAD CAP	2	
03	S 604	18	弹簧垫圈	WASHER,LOCK	2	
02	205492	21	推杆	ROD,PUSH	12	
02	3017961	20	喷油推杆	ROD,PUSH	6	

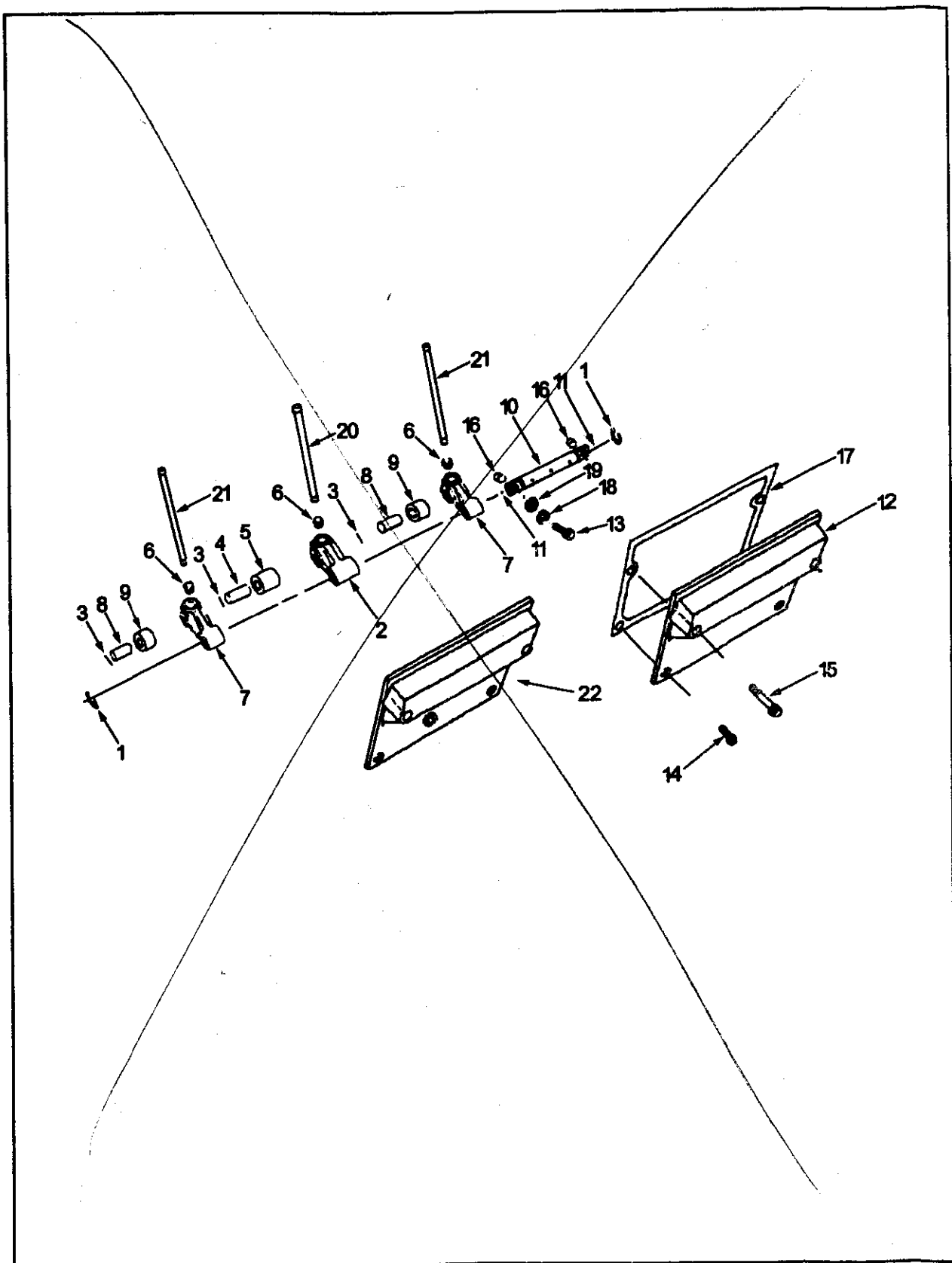

凸轮轴从动件 G4

级别	零件号	图上 标号	零件名称		数量	备注
			中文	英文		
02	3078180		凸轮轴从动件	FOLLOWER,CAMSHAFT	6	G4
03	205439	1	卡环	RING,RETAINING	2	
03	3039164	B	凸轮从动件	LEVER,CAM FOLLOWER	2	
04	205071	8	气门凸轮从动件滚轮销	PIN,CAM FOLLOWER ROLLER	1	
04	205438	3	滚轮锁紧钢丝	LOCKWIRE,TPT ROLLER PIN	1	
04	213559	6	凸轮轴从动件凹头	SOCKET,CAM FOLLOWER	1	
04	3016826	9	凸轮从动件滚轮	ROLLER,CAM FOLLOWER	1	
04	3655378	7	气门凸轮从动件分总成	LEVER,CAM FOLLOW	1	
03	3078218		轴和管塞	SHAFT,CAM FOLLOWER	1	
04	205227	11	碗形塞	PLUG,EXPANSION	2	
04	3077538	10	凸轮从动件轴	SHAFT,CAM FOLLOWER	1	
03	3081413		凸轮随动件	LEVER,CAM FOLLOWER	1	
04	205438	3	滚轮锁紧钢丝	LOCKWIRE,TPT ROLLER PIN	1	
04	213559	6	凸轮轴从动件凹头	SOCKET,CAM FOLLOWER	1	
04	3062141	5	凸轮从动件滚轮	ROLLER,CAM FOLLOWER	1	
04	3081411	2	喷油凸轮从动件分总成	LEVER,CAM FOLLOWER	1	
04	3081412	4	喷油凸轮从动件滚轮销	PIN,CAM FOLLOWER	1	
02	MP 4987		凸轮从动件安装	FOLLOWER,CAMSHAFT	6	
03	127362	19	平垫圈	WASHER,PLAIN	2	
03	3002886	13	凸轮从动件螺栓	SCREW,CAMFOLLOWER	2	
03	3002993	16	定位环	DOWEL,RING	2	
03	S 604	18	弹簧垫圈	WASHER,LOCK	2	
02	3628755	12	凸轮从动件盖	COVER CAMSHAFT	3	
02	3628756	22	凸轮从动件盖	COVER CAMSHAFT	1	
02	MP 5297		凸轮从动件盖安装	COVER,CAM FOLLOWER	5	
03	127362	19	平垫圈	WASHER,PLAIN	4	
03	3010596	14	带垫圈螺栓	SCREW,CAPTIVE WAS	2	
03	3040721	17	凸轮从动件衬垫	GASKET,CAM FOL HOUSING	1	
03	S 126	15	六角螺栓	SCREW,HEXAGON HEAD CAP	2	
03	S 604	18	弹簧垫圈	WASHER,LOCK	2	
02	3077983		凸轮轴从动件盖安装	COVER,CAM FOLLOWER	1	
03	3040721	17	凸轮从动件衬垫	GASKET,CAM FOL HOUSING	1	
03	3040838	23	带垫螺栓	SCREW,CAPTIVE WASHER CAP	2	
03	3060567	24	带垫螺栓	SCREW,CAPTIVE WASHER CAP	2	
03	3088375	25	支架	BRACKET,VALVE	1	
02	205492	21	推杆	ROD,PUSH	12	
02	3017961	20	喷油推杆	ROD,PUSH	6	

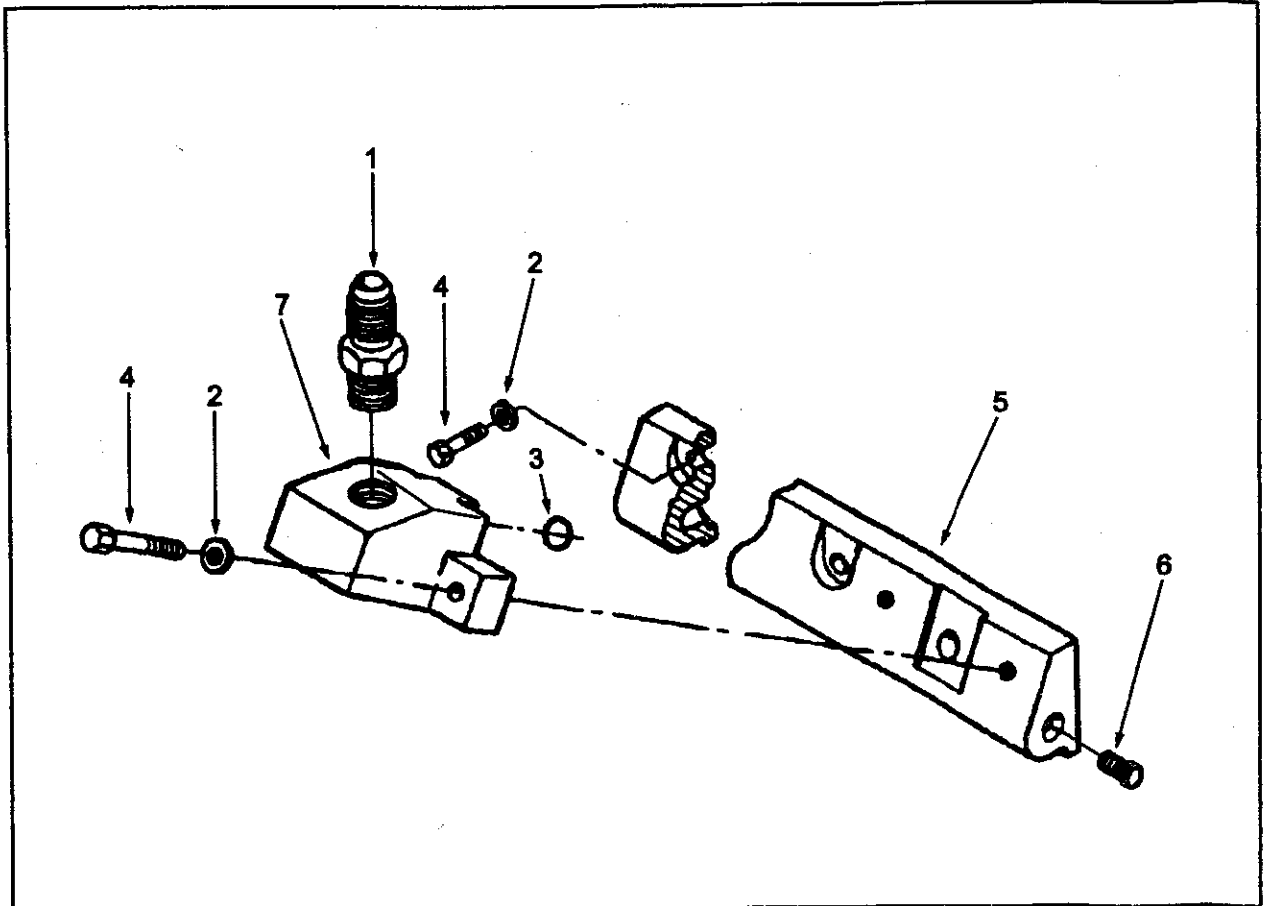

级别	零件号	图上 标号	零件名称		数量	备注
			中文	英文		
02	3040232		油管总成	MANIFOLD,OIL	1	
03	118346	1	接头	UNION,MALE	1	
03	127018	2	平垫圈	WASHER,PLAIN	8	
03	3001340	3	O型密封圈	SEAL,O RING	1	
03	3001811	4	十二角螺栓	SCREW,TWELVE POINT CAP	8	
03	3023217	6	螺塞	PLUG,THREADED	2	
03	3037657	7	供油接头	CONNECTION,OIL SUPPLY	1	
03	3084539		O型圈	SEAL,O RING	6	
03	3084620	5	油管	MANIFOLD,OIL	1	

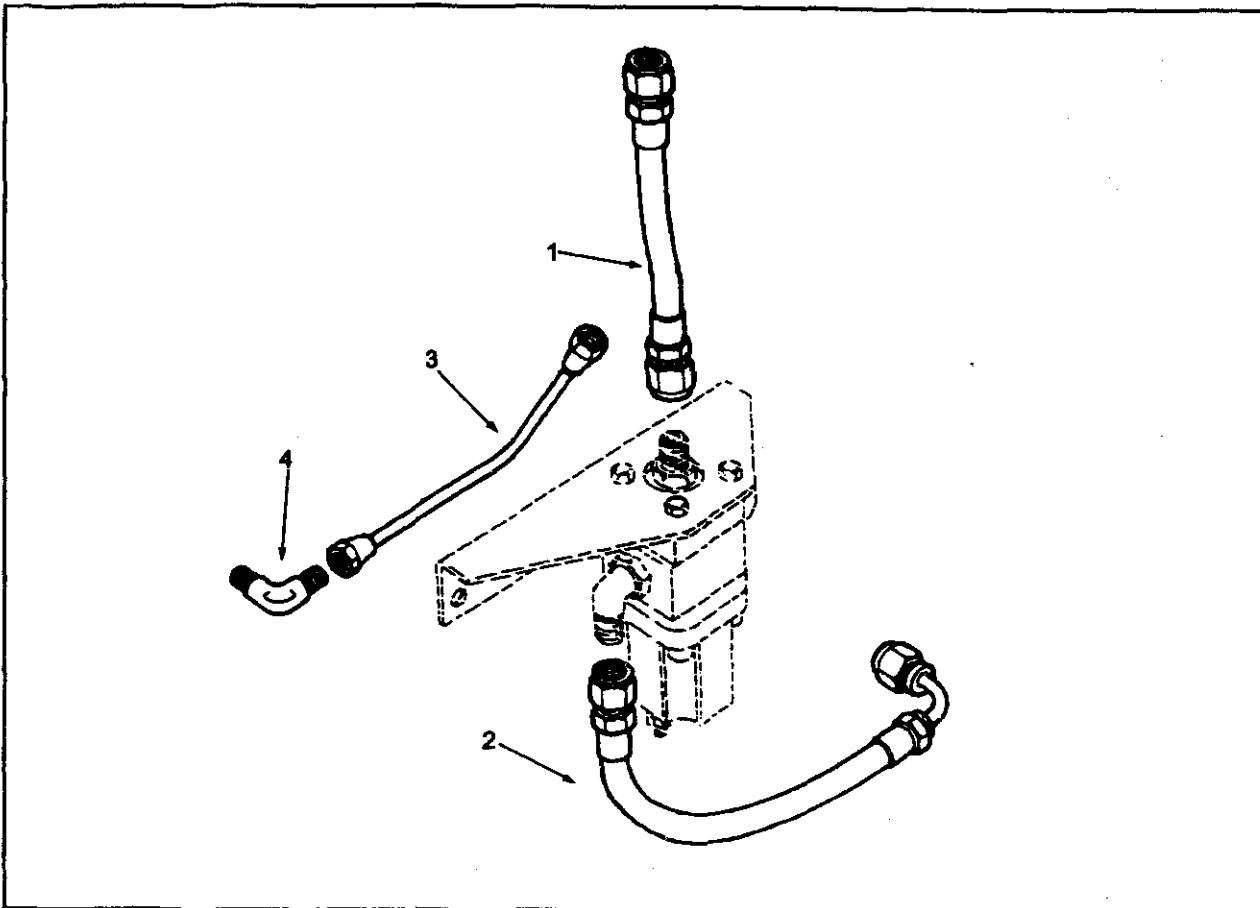

级别	零件号	图上 标号	零件名称		数量	备注
			中文	英文		
02	3065839		供油管安装	PLUMBING,HVT OIL SUPPLY	1	G3
03	3035580	2	软管	HOSE,FLEXIBLE	1	
03	3037660	3	油管	TUBE,LUB OIL DRAIN	1	
03	3037662	4	阳性弯接头	ELBOW,MALE UNION	1	
03	AS 6008 SS	1	柔性软管	HOSE,FLEXIBLE	1	

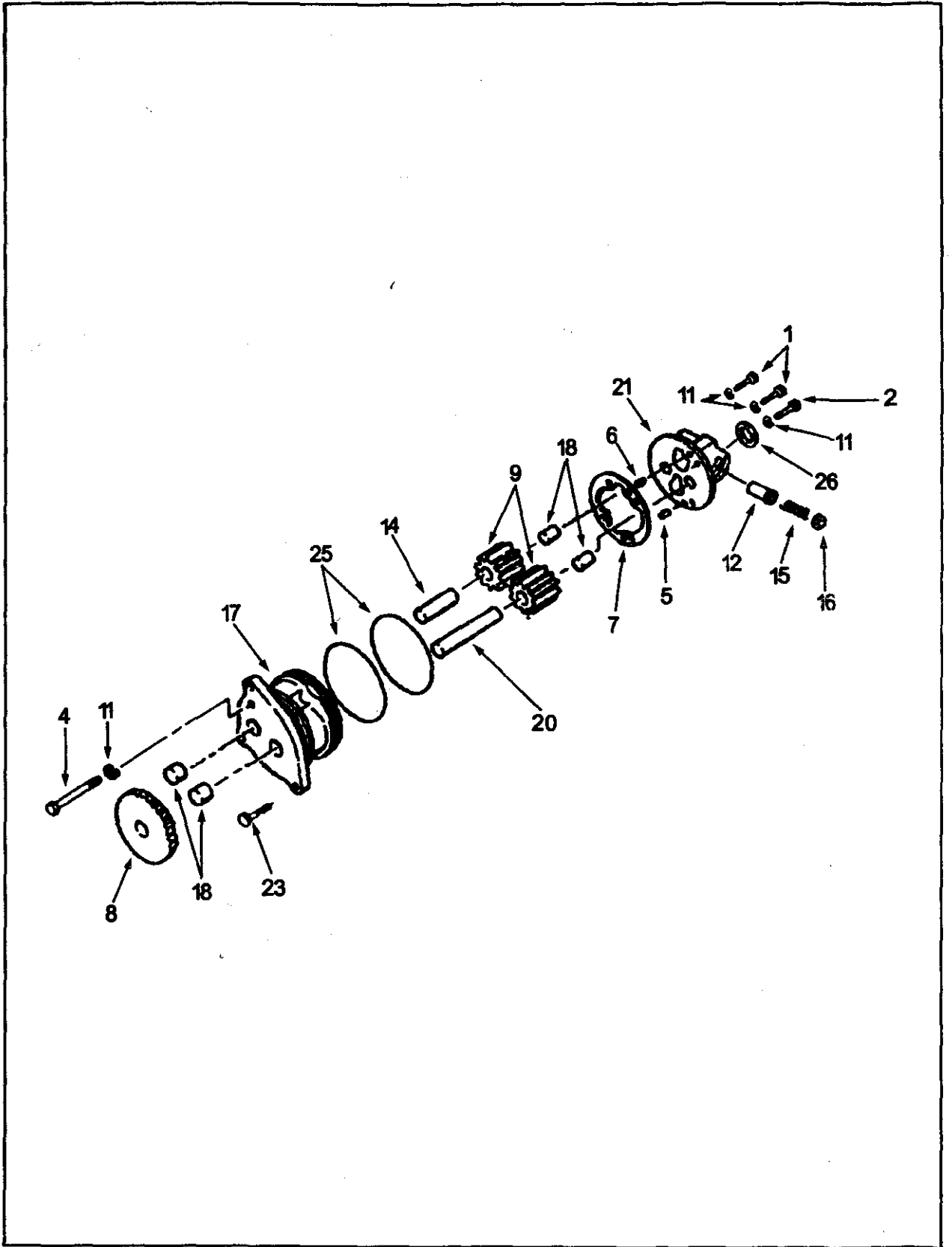

表—11

机 油 泵

BP 4016、BP4026

级 别	零 件 号	图 上 标 号	零 件 名 称		数 量	备 注
			中 文	英 文		
02	3047549		机油泵总成	PUMP,LUBRICATING OIL	1	总成装配
03	148554		定位销	DOWEL,PIN	1	
03	205061	7	机油泵垫片	GASKET,LUB OIL PUMP	1	
03	205080	12	压力调节器柱塞	PLUNGER,PRS REGULATOR	1	
03	205202		齿轮与轴	GEAR & SHAFT	1	
04	146942	9	机油泵齿轮	GEAR,LUB OIL PUMPING	1	
04	205052	14	被动轮轴	SHAFT,IDLER	1	
03	207279		机油泵	PUMP,LUBRICATING OIL	1	
04	70760	5	定位销	DOWEL,PIN	1	
04	107948	6	菱形定位销	DOWEL,DIAMOND	1	
04	205057		机油泵体总成	BODY,LUBRICATING OIL PUMP	1	
05	69521	18	衬套	BUSHING	2	
05	205049	17	机油泵体	BODY,LUBRICATING	1	
04	205077		齿轮与轴	GEAR & SHAFT	1	
05	146942	9	机油泵齿轮	GEAR,LUB OIL PUMPING	1	
05	205065	20	机油泵驱动轴	SHAFT,LUB PUMP D	1	
04	207252	8	机油泵驱动齿轮	GEAR,LUBRICATING OIL PUMP	1	
03	3047548		机油泵盖总成	COVER,LUB OIL PUMP	1	
04	69521	18	衬套	BUSHING	2	
04	3009955	21	机油泵盖	COVER,LUB OIL PUMP	1	
03	3062415	15	压力调节器弹簧	SPRING,COMPRESSION	1	
03	3200934	16	挡塞	PLUG,RETAINER	1	
03	S 126	1	六角螺栓	SCREW,HEXAGON HEAD CAP	2	
03	S 141	2	螺栓	SCREW,HEXAGON HEAD CAP	1	
03	S 199	4	六角螺栓	SCREW,HEXAGON HEAD CAP	1	
03	S 604	11	弹簧垫圈	WASHER,LOCK	4	
02	MP 4973		机油泵安装件	PUMP,LUB OIL MTG	1	
03	205898	25	O型密封圈	SEAL,ORING	2	
03	207135	26	矩形密封圈	SEAL,RECTANGULAR	1	
03	3010596	23	带垫圈螺栓	SCREW,HEXAGON HEAD CAP	3	

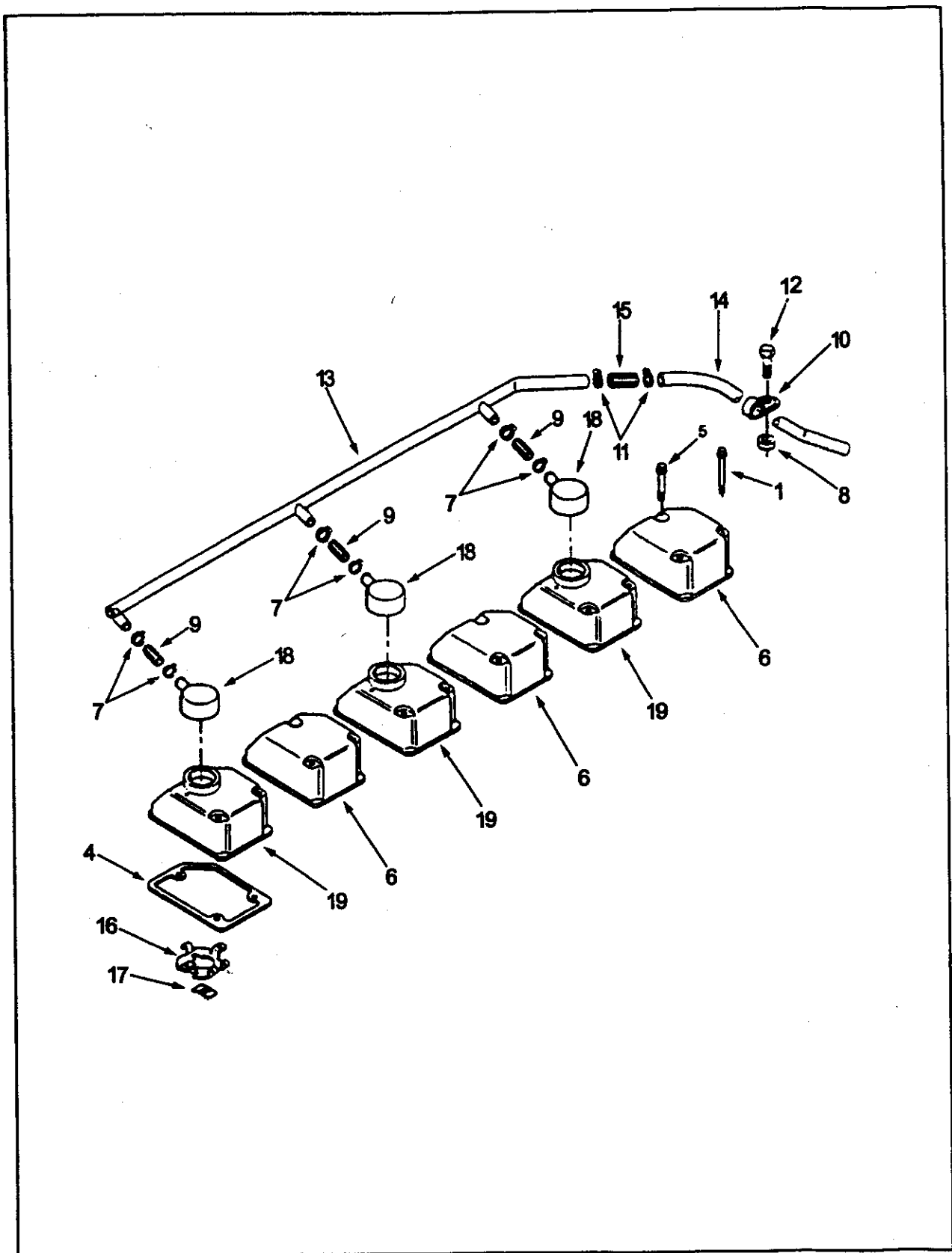

表—12

曲轴箱通风器

BR 4027

级别	零件号	图上 标号	零件名称		数量	备注
			中文	英文		
02	3047710		摇臂室盖总成	COVER,ROCKER ARM HSG	3	
03	219065	16	通气孔挡板	BAF-FLE.BREATHER	1	
03	3000528	17	矩形弹性螺母	NUT,SPRING	2	
03	3046853		摇臂室盖	COVER,ROCKER LEVER	1	
04	3008595	18	曲轴箱通风器	BREATHER,CRANKCASE	1	
04	3010396	19	摇臂室盖	COLER,ROCKER LEVER	1	
02	3010388	6	摇臂室盖	COVER,ROCKER LEVER	3	
02	3010249		摇臂室盖安装	COVER VALVE MTG	6	
03	3044413	5	带垫螺栓	SCREW,CAPTIVE WASHER	1	
03	3629140	4	摇臂室盖衬垫	GASKET,ROCKER LEVER COVE	1	
03	S 169	A 1	六角螺栓	SCREW,HEXAGON HEAD CAP	2	
03	S 602		平垫圈	WASHER,PLAIN	2	
03	S 604		弹簧垫圈	WASHER,LOCK	2	
02	3047205		通风管	TUBE,BREATHER	1	
03	43828	7	软管夹	CLAMP,HOSE	6	
03	63385	8	隔套	SPACER,WATER CONNECTION	2	
03	64775	9	软管	HOSE,PLAIN	3	
03	67949	10	夹子	CLIP	2	
03	3012475	12	带垫螺栓	SCREW,CAPTIVE WAS	2	
03	3026806	11	抱箍	CLAMP,HOSE	2	
03	3046834	13	通风管	TUBE,BREATHER	1	
03	3046838	14	通风管	TUBE,BREATHER	1	
03	3200316	15	普通软管	HOSE,PLAIN	1	

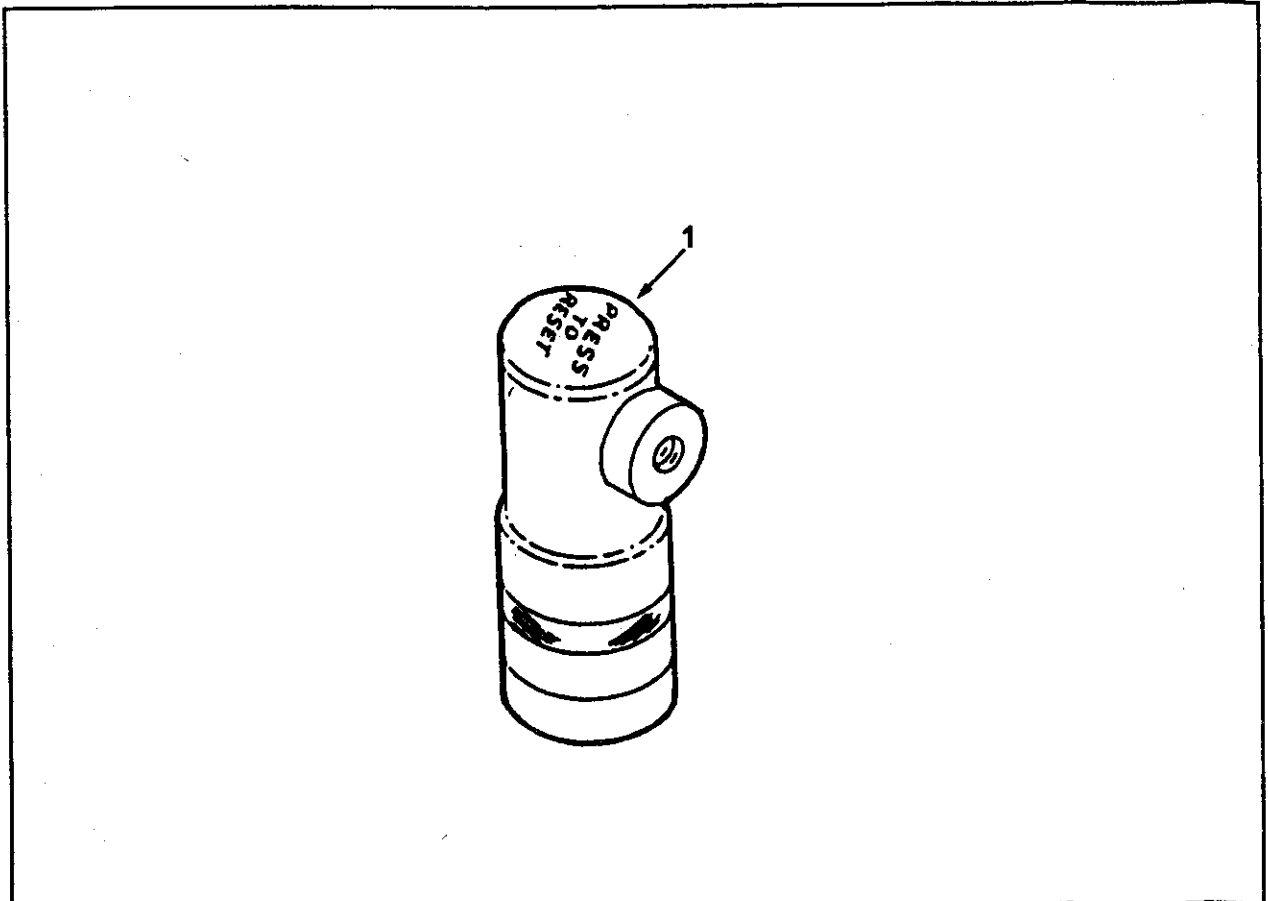

级别	零件号	图上 标号	零件名称		数量	备注
			中文	英文		
02	178957	1	空气阻力指示器	INDICATOR,RESTRICTION	1	

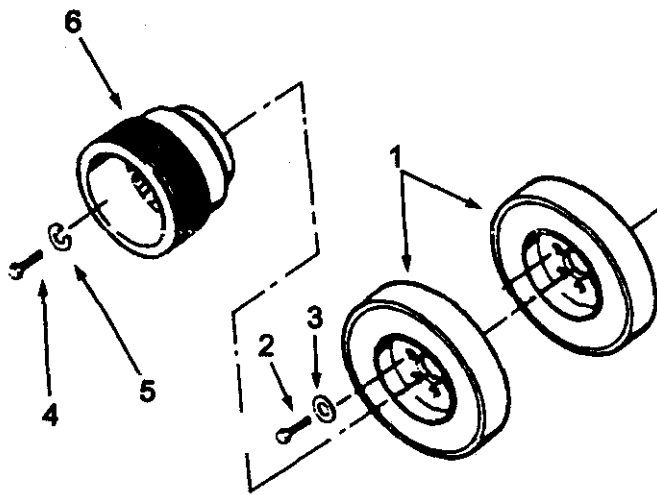

级别	零件号	图上 标号	零件名称		数量	备注
			中文	英文		
02	217322	1	硅油减振器	DAMPER,VIBRATION	2	
02	3003696	6	曲轴皮带轮	PULLEY,CRANKSHAFT	1	
02	MP45208		减振器安装	DAMPER,VIBRATION MTG	1	
03	205059	3	平垫圈	WASHER,CYLINDER	6	
03	206881	4	十二角螺栓	SCREW,TWELVE POINT	6	
03	206929	2	六角螺栓	SCREW,TWELVE POINT	6	

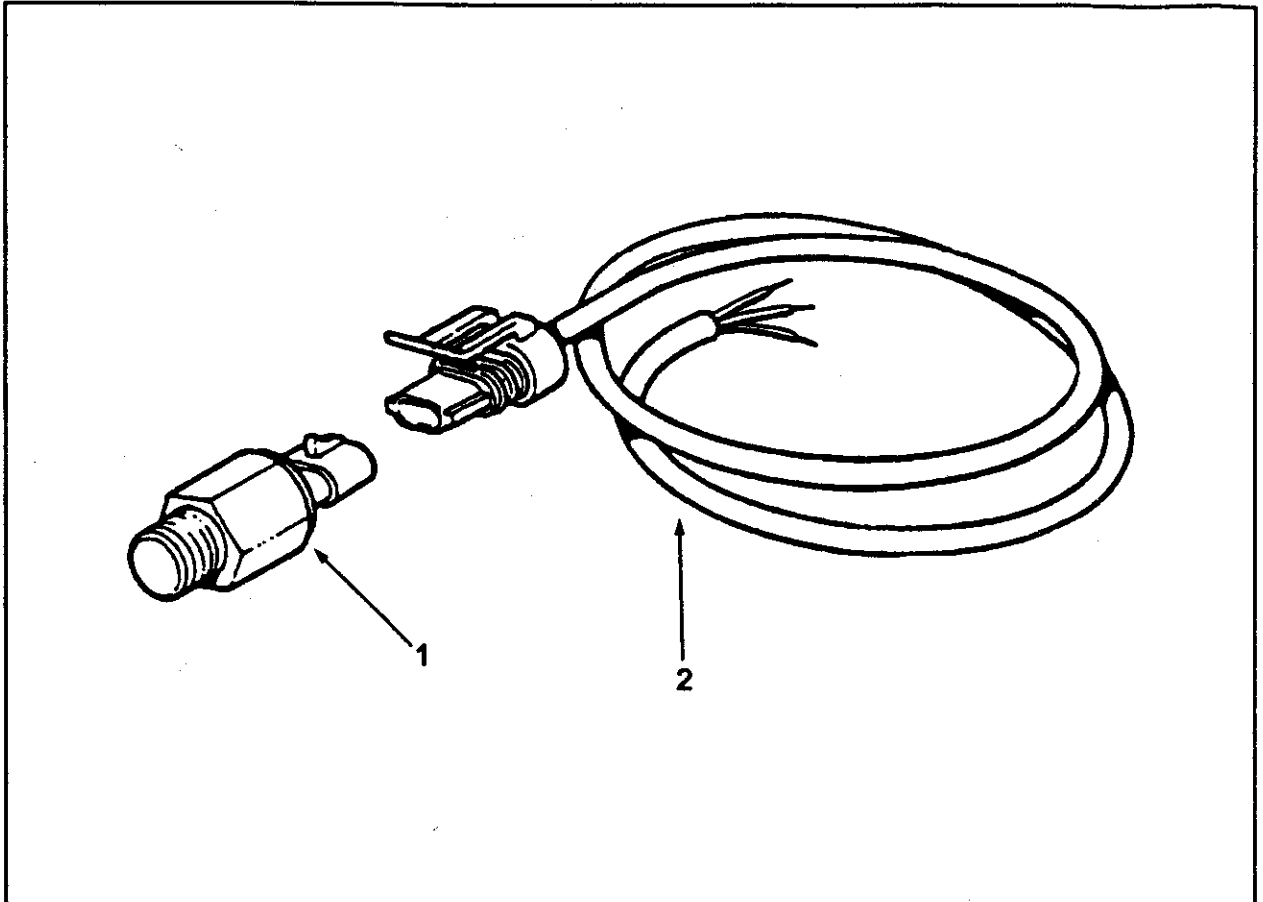

级 别	零 件 号	图 上 标 号	零 件 名 称		数 量	备 注
			中 文	英 文		
02	3056344	1	油压报警开关	SWITCH,PRESSURE	1	

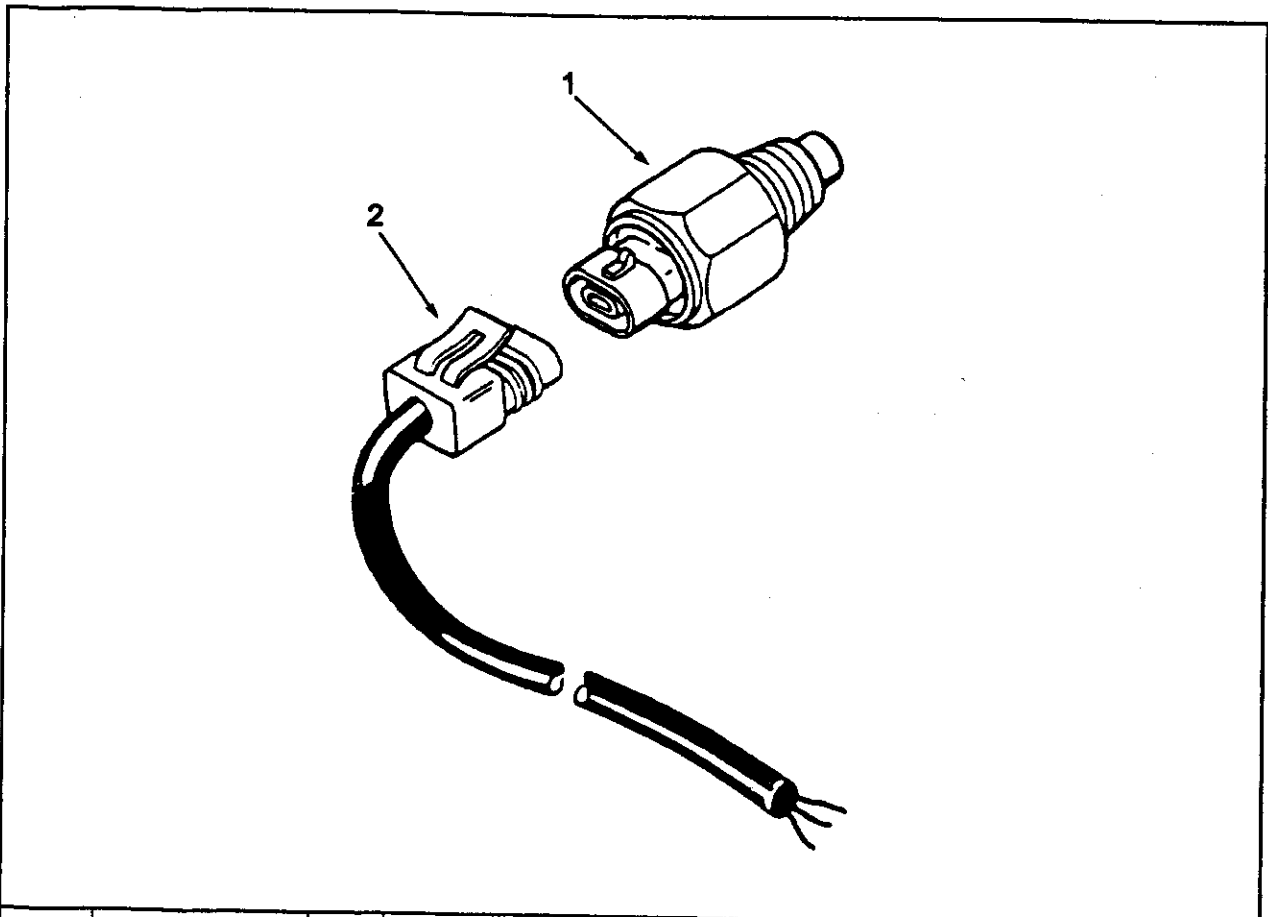

级别	零件号	图上 标号	零件名称		数量	备注
			中文	英文		
02	3056353	1	水温报警开关	SWITCH,TEMPERATURE	1	

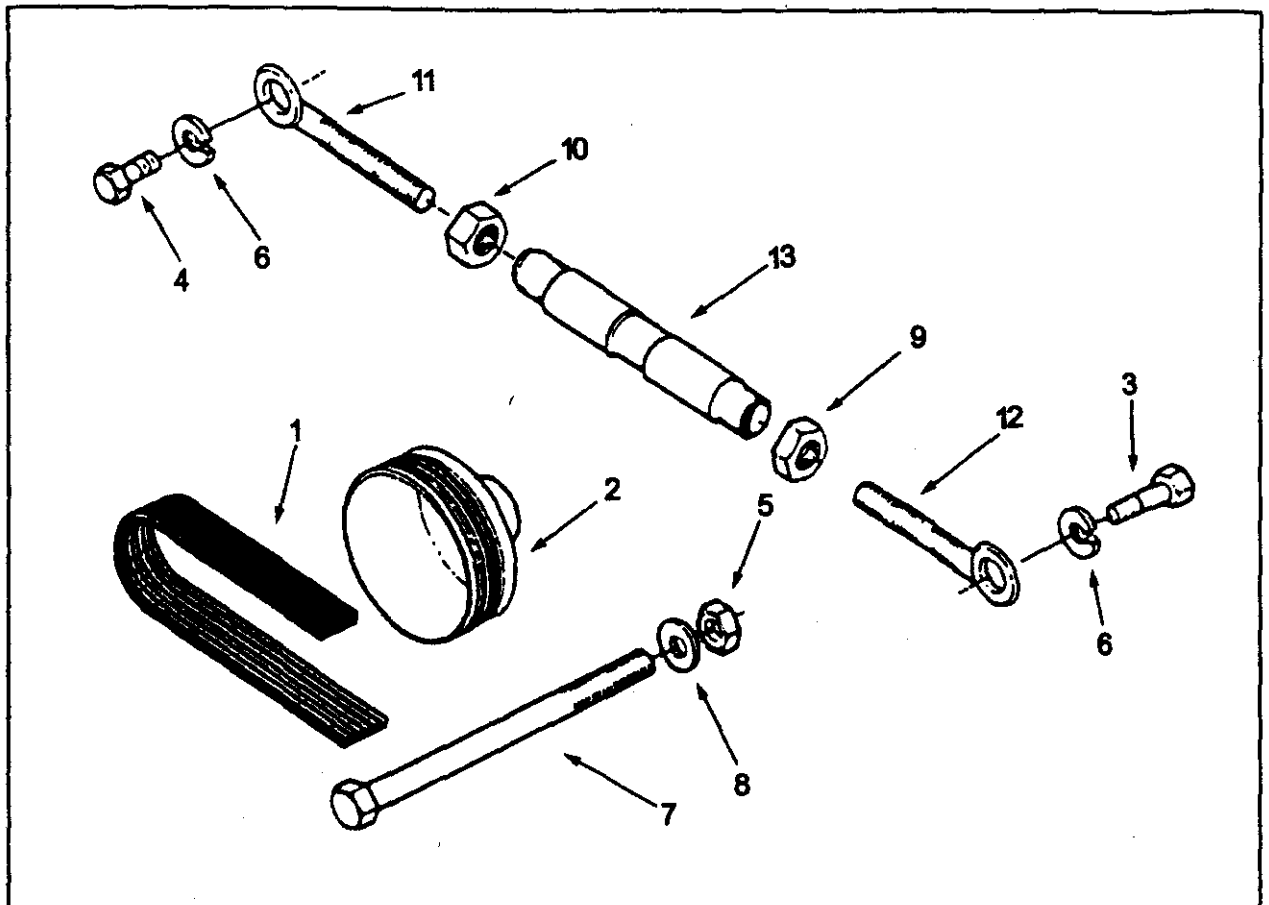

级别	零件号	图上 标号	零件名称		数量	备注
			中文	英文		
02	206996	1	多槽皮带	BELT,VRIBBED	1	
02	3002323	2	发电机皮带轮	PULLEY,ALTERNATOR	1	
02	3200769		发电机安装	ALTERNATOR MTG	1	
03	70897	5	锁紧螺母	NUT,LOCK	1	
03	111445	6	弹簧垫圈	LCK,WSHR	2	
03	158829	7	六角螺栓	SCREW,HEXAGONHEAD	1	
03	203310	8	平垫圈	WASHER,PLAIN	3	
03	S 106	3	六角螺栓	SCREW,HEXAGON HEAD	1	
03	S 113	4	六角螺栓	SCREW,HEXAGON HEAD	1	
03	3419317		调节杆	LINK,ADJUSTING	1	
04	Q35112	9	六角螺母	NUT,REGULAR HEXGON	1	
04	3419324	10	螺母	UNT,JAM	1	
04	3419318	11	带孔螺栓	BOLT,EYE	1	
04	3419319	12	带孔螺栓	BOLT,EYE	1	
04	3419320	13	调节杆	LINK,ADJUSTING	1	

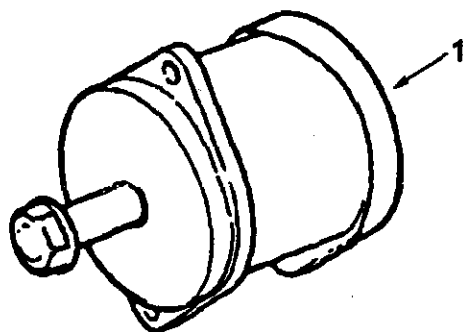

级别	零件号	图上 标号	零件名称		数量	备注
			中文	英文		
02	3016627	1	充电机	ALTERNATOR	1	

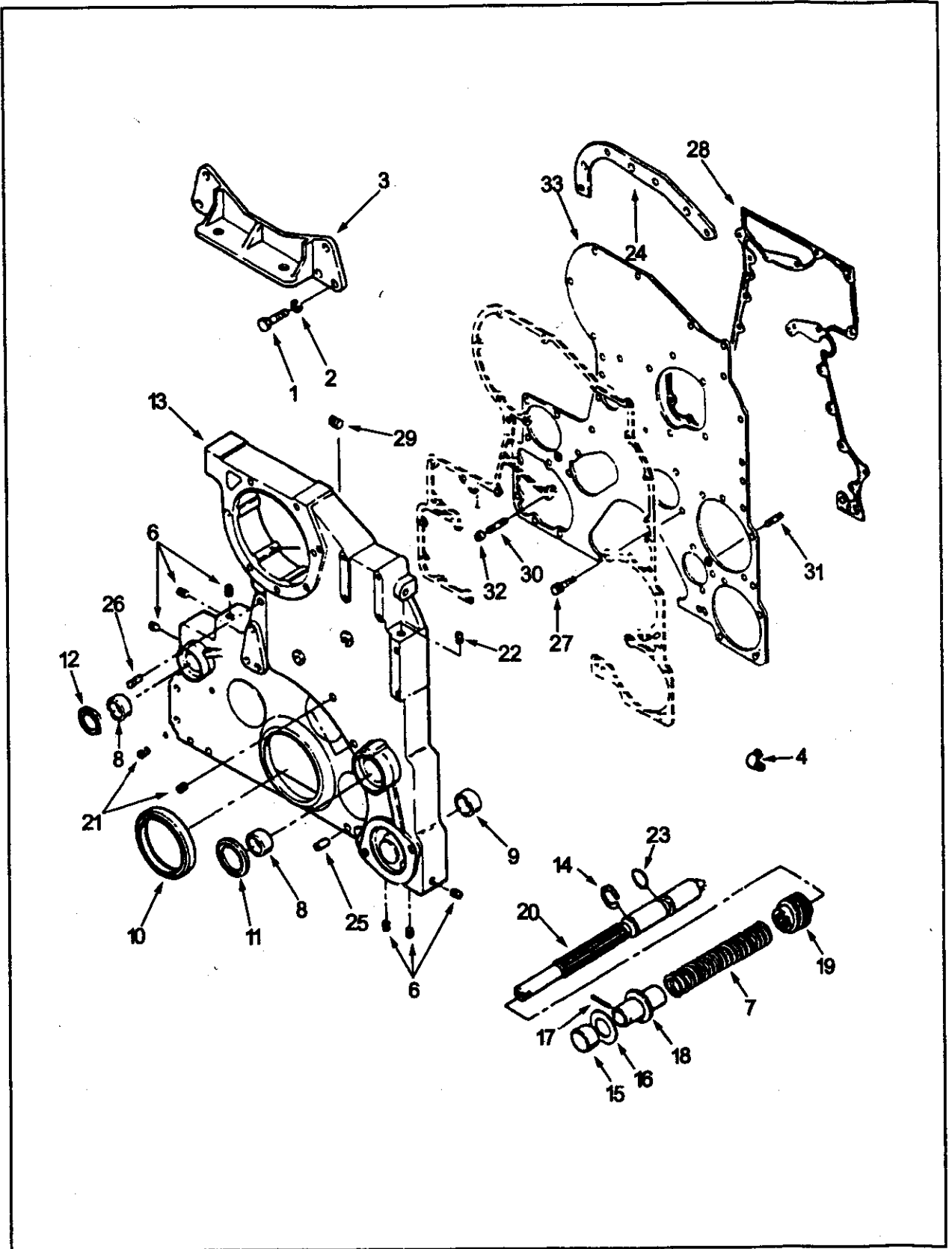

齿 轮 室 盖

级 别	零 件 号	图 上 标 号	零 件 名 称		数 量	备 注
			中 文	英 文		
02	3165637		正室齿轮室盖总成	COVER,GEAR	1	
03	3004242		液压泵盖板衬垫	GASKET	1	
03	3009620	7	发动机盘车弹簧	SPRING,ENGINE BAR	1	
03	3012302		正时齿轮室盖分总成	COVER,GEAR	1	
04	132770	8	衬套	BUSHING	2	
04	205133	9	衬套	BUSHING	1	
04	3007362	13	正时齿轮室盖	COVER,GEAR	1	
04	3016787	10	油封	SEAL,OIL	1	
04	3016791	12	油封	SEAL,OIL	1	
04	3628895	11	油封	SEAL,OIL	1	
03	3013786	21	管塞	PLUG,PIPE	2	
03	3015525	14	挡圈	RING,RETAINING	1	
03	3018914		盘车轴套	GUIDE,BARRING SHAFT	1	
	3018909	15	衬套	BUSHING	1	
	3018910	16	止推轴承	BEARING,THRUST	1	
	3018911	17	圆销	PIN,ROLL	1	
	3019154	18	盘车轴	GUIDE,BARRING SHAFT	1	
03	3019152	19	发动机盘车齿轮	GEAR,ENGING BARRING	1	
03	3019153	20	盘车轴	SHAFT,BARRING	1	
03	3025460	6	管塞	PLUG,PIPE	6	
03	3200782		法兰盖板	COVER	1	
03	3201125	23	O型密封圈	SEAL ORING	1	
03	S 145		六角螺栓	SCREW	2	
03	S 608		弹簧垫圈	WASHER,LOCK	2	
03	S 965	E 29	管塞	PLUG,PIPE	1	
02	3044522		正时齿轮室板	PLATE,GEAR COVER	1	
03	206217	30	双头螺栓	STUD	1	
03	206218	31	双头螺栓	STUD	1	
03	3019961	32	堵塞螺母	NUT,PLUG	2	
03	3044521	33	正时齿轮室板	PLATE,GEAR COVER	1	
02	3016717		正时齿轮室板安装	MTG,GEAR COVER	1	
03	70645	25	主定位销	DOWEL PIN	1	
03	102957	26	定位销	DOWEL,DIAMOND	1	
03	3014766	27	带垫螺栓	SCREW,CAPTIVE WASHER CAP	12	
03	3410141	28	衬垫	GASKET,COVER PIAT	1	

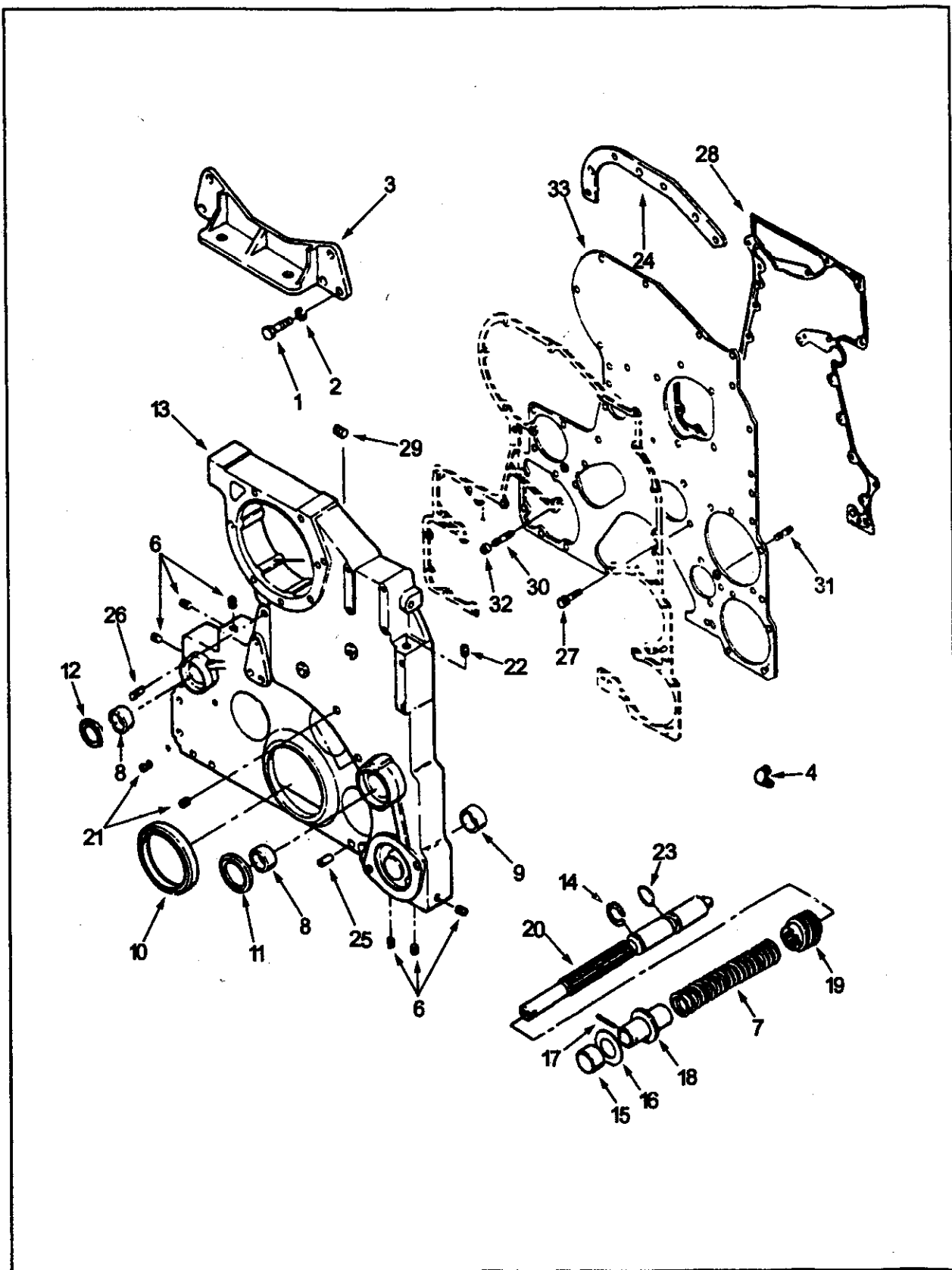

齿 轮 室 盖

级 别	零 件 号	图 上 标 号	零 件 名 称		数 量	备 注
			中 文	英 文		
02	AR10702		发动机前支架安装	SUPPURT,FRONT EN	1	
03	206343	3	发动机前支架	SUPPORT,FRONT ENGING	1	
03	S 173 A	1	六角螺栓	SCREW,HEXAGON HEAD	6	
03	S 603	2	弹簧垫圈	WASHER,LOCK	6	
02	3200642	24	夹板	PLATIE CLAMPING	1	

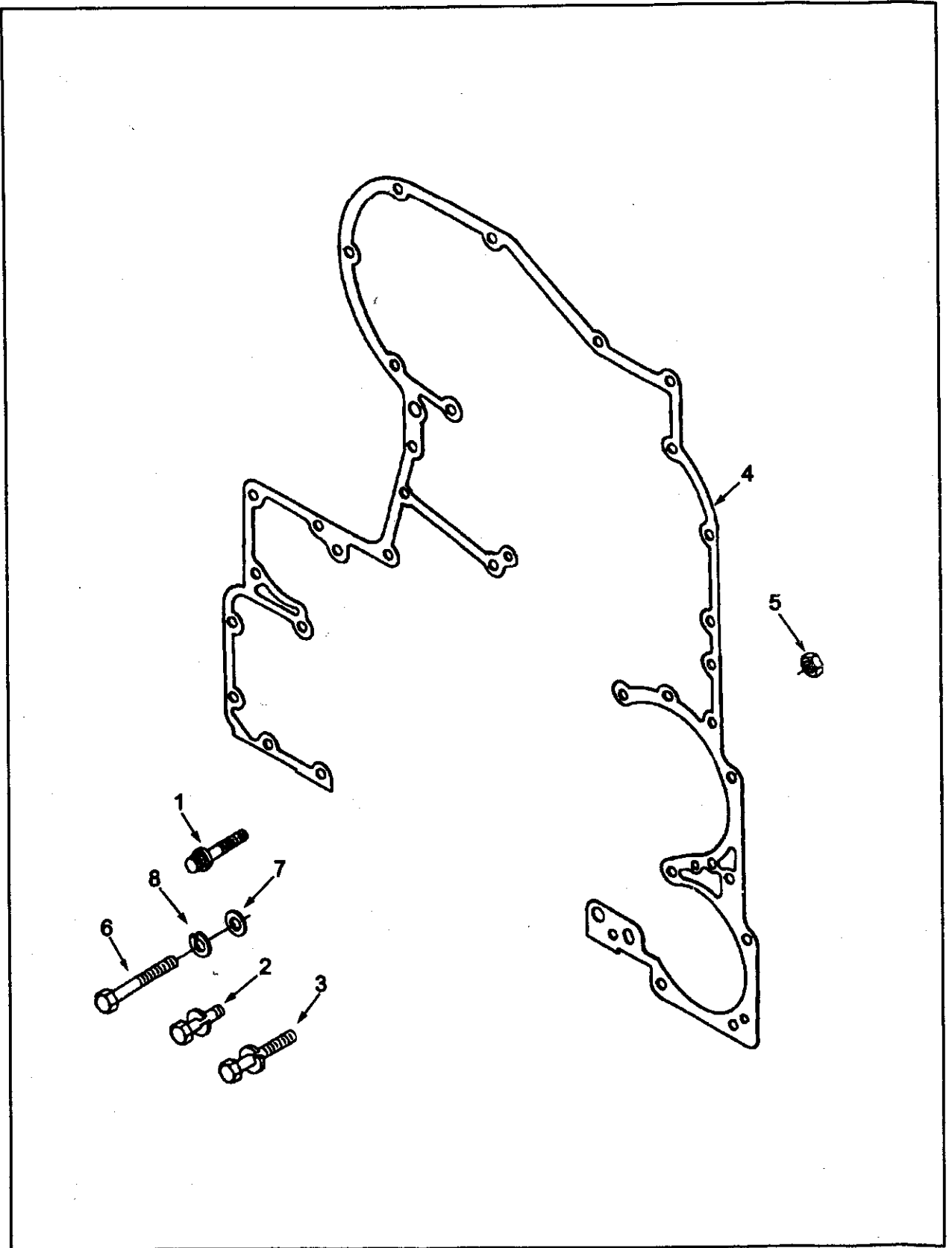

齿 轮 室 盖 安 装

级 别	零 件 号	图 上 标 号	零 件 名 称		数 量	备 注
			中 文	英 文		
02	3018025		齿轮室盖安装	COVER,GEARMOUNTI	1	
03	127362		平垫圈	WASHER,PLAIN	9	
03	205375	1	十二角螺栓	SCREW,TWELVE POINT CAP	1	
03	3010596	2	带垫圈螺栓	SCREW,CAPTIVE WAS	3	
03	3012476	3	带垫螺栓	SCREW,CAPTIVE WAS	8	
03	3074690	4	齿轮室盖衬垫	GASKET,GEAR COVER	1	
03	3201128	5	六角螺母	NUT,REGULAR HEXG	4	
03	S 199 B	6	六角螺栓	SCREW,HEXAGON HEAD	7	
03	S 602	7	平垫圈	WASHER,PLAIN	7	
03	S 604	8	弹簧垫圈	WASHER,LOCK	7	

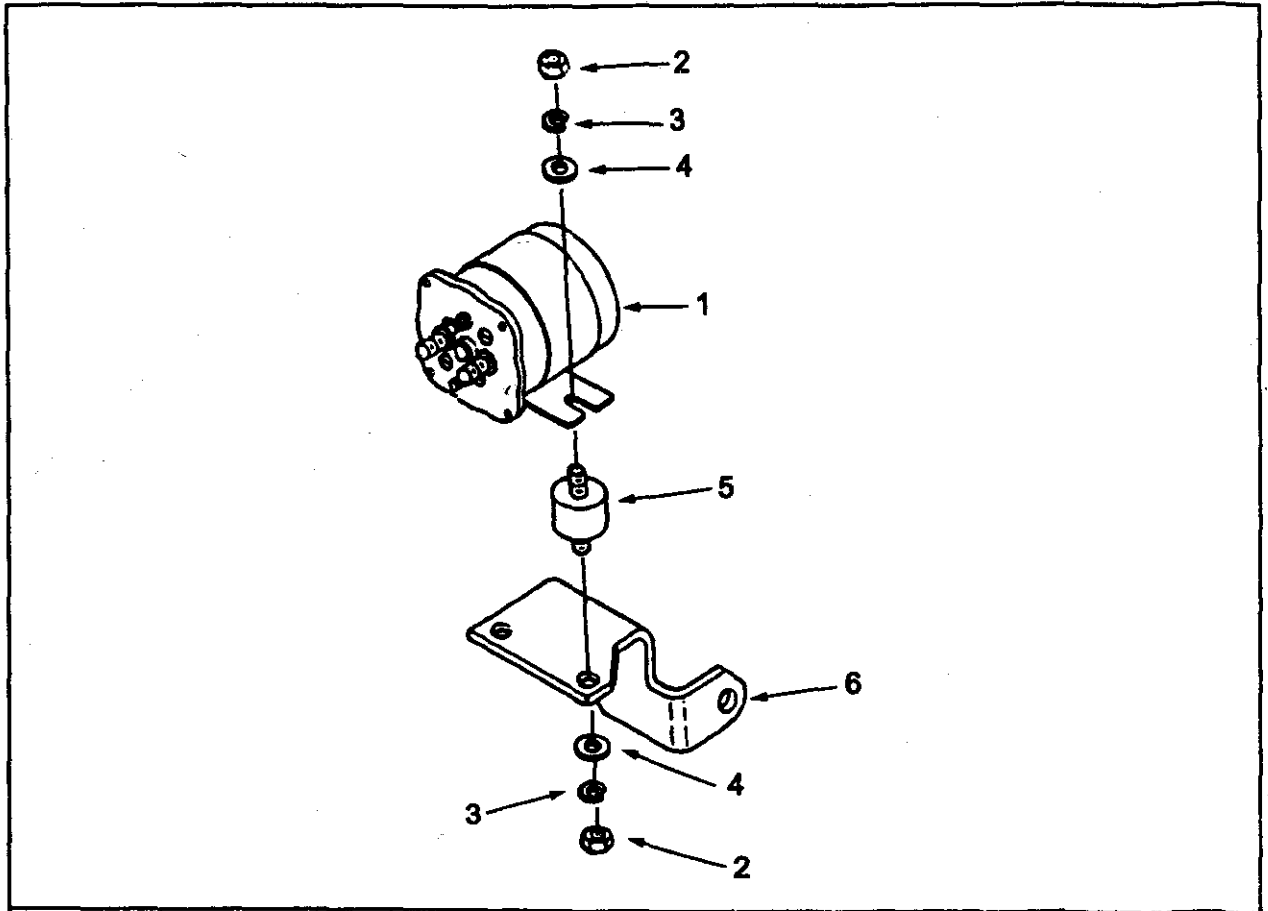

级别	零件号	图上 标号	零件名称		数量	备注
			中文	英文		
02	3050692	1	电磁开关	SWITCH,MAGNETIC	1	
02	3052529		磁力开关安装件	SWITCH,MAGNETIC	1	
03	S 224	2	六角厚螺母	NUT,HEAVY HEXAGON JAM	4	
03	S 600	3	弹簧垫圈	WASHER,LOCK	4	
03	S 631	4	平垫圈	WASHER,PLAIN	4	
03	204493	5	减振垫	SCREW,HEXAGON HEAD	2	
03	3062483	6	安装支架	BRACKET,MAGNETIC	1	

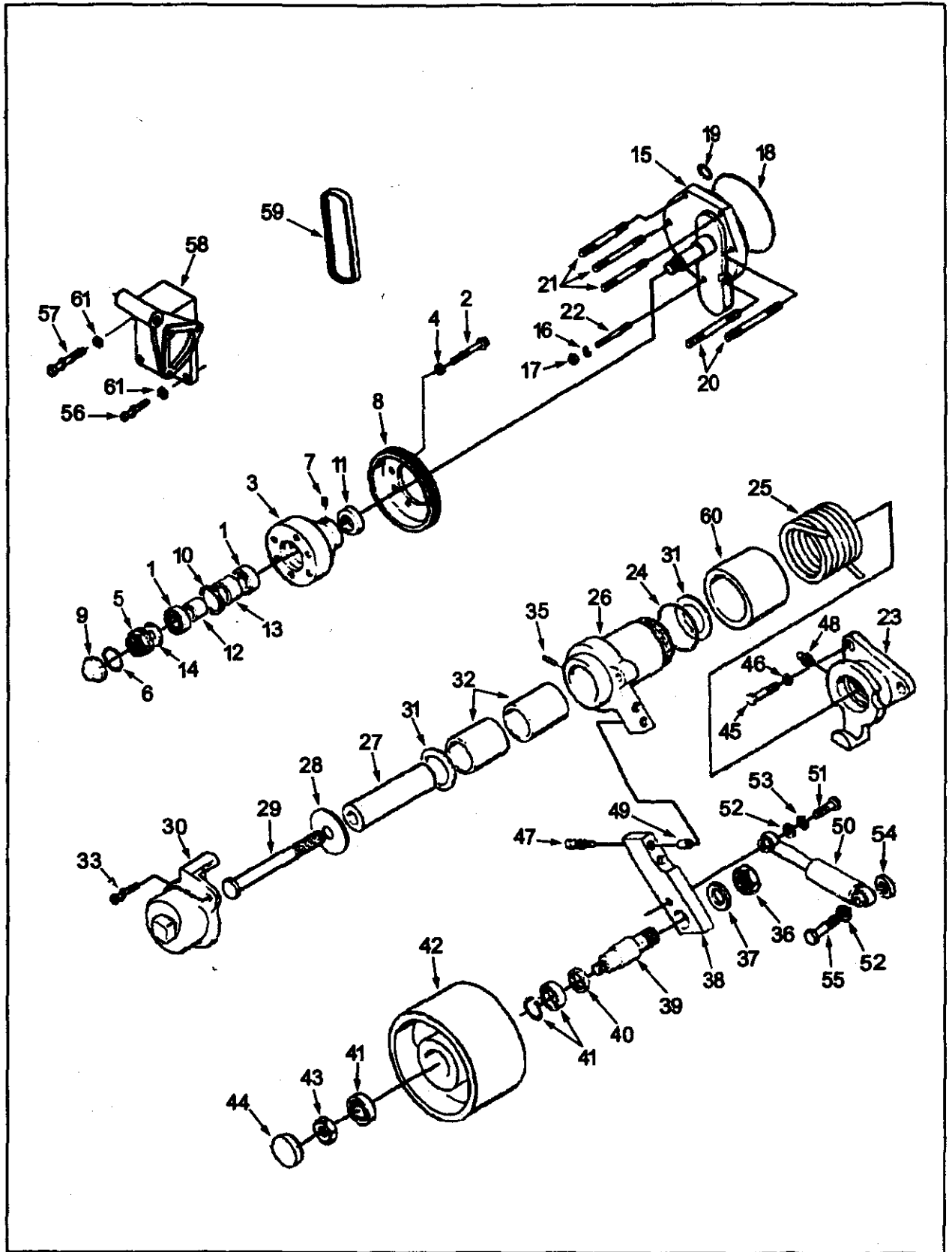

风 扇 轮 毅

级 别	零 件 号	图 上 标 号	零 件 名 称		数 量	备 注
			中 文	英 文		
02	3002232		风扇轮毂	HUB,FAN	1	
03	111445	4	弹簧垫圈	LCK,WSHR	6	
03	142176	5	锁紧螺母	NUT,LOCK	1	
03	145551	6	O型密封圈	SEAL,O RING	1	
03	206041	2	十二角螺栓	SCREW,TWELVE POINT	6	
03	3001280	10	挡圈	RING,RETAINING	1	
03	3002183	3	风扇轮毂	HUB,FAN	1	
03	3002193	9	风扇轮毂罩壳	COVER,FAN HUB	1	
03	3002210	12	轴承隔套	SPCER,BEARING	1	
03	3002211	13	轴承隔套	SPACER,BREARING	1	
03	3002220	8	风扇皮带轮	PULLEY,FAN	1	
03	3012467	14	平垫圈	WASHER,PLAIN	1	
03	3036139	15	风扇轴	SPINDLE,FAN	1	
03	3062393	11	油封	SEAL,OIL	1	
03	3419359	A	调整垫片	SHIM	1	
03	3419359	B	调整垫片	SHIM	1	
03	3419359	C	调整垫片	SHIM	1	
03	3419360	A	调整垫片	SHIM	1	
03	3419360	B	调整垫片	SHIM	1	
03	3419360	C	调整垫片	SHIM	1	
03	3655115	1	滚动轴承	BEARING ROLLER	2	
03	S 911	B 7	管塞	PLUG,PIPE	2	
02	3200798		风扇轮毂安装	HUB,FAN MTG	1	
03	64929	20	双头螺栓	SDUD	2	
03	102397	21	双头螺栓	STUD	4	
03	3000859	18	O型密封圈	SEAL,O RING	1	
03	3201117	22	双头螺栓	STUD	1	
03	3201659	19	矩型密封圈	SEAL,RECTANGULAR RING	1	
03	S 205	17	六角螺母	NUT,REGULAR HEXAGON	7	
03	S 604	16	弹簧垫圈	WASHER,LOCK	7	
02	3201022		风扇张紧轮杆阻尼器	ABSORBER,IDLER ARM	1	
03	108708	51	六角螺栓	SCREW,HEXAGON HEAD	1	
03	3008018	50	阻尼器	ABSORBER, SCHOCK	1	
03	3200905	54	隔套	SPACER,MTG	1	
03	3201283	55	六角螺栓	SCREW,HEXAGON HEAD	1	
03	S 610	53	弹簧垫圈	WASHER,LOCK	1	
03	S 622	52	平垫圈	WASHER,PLAIN	2	

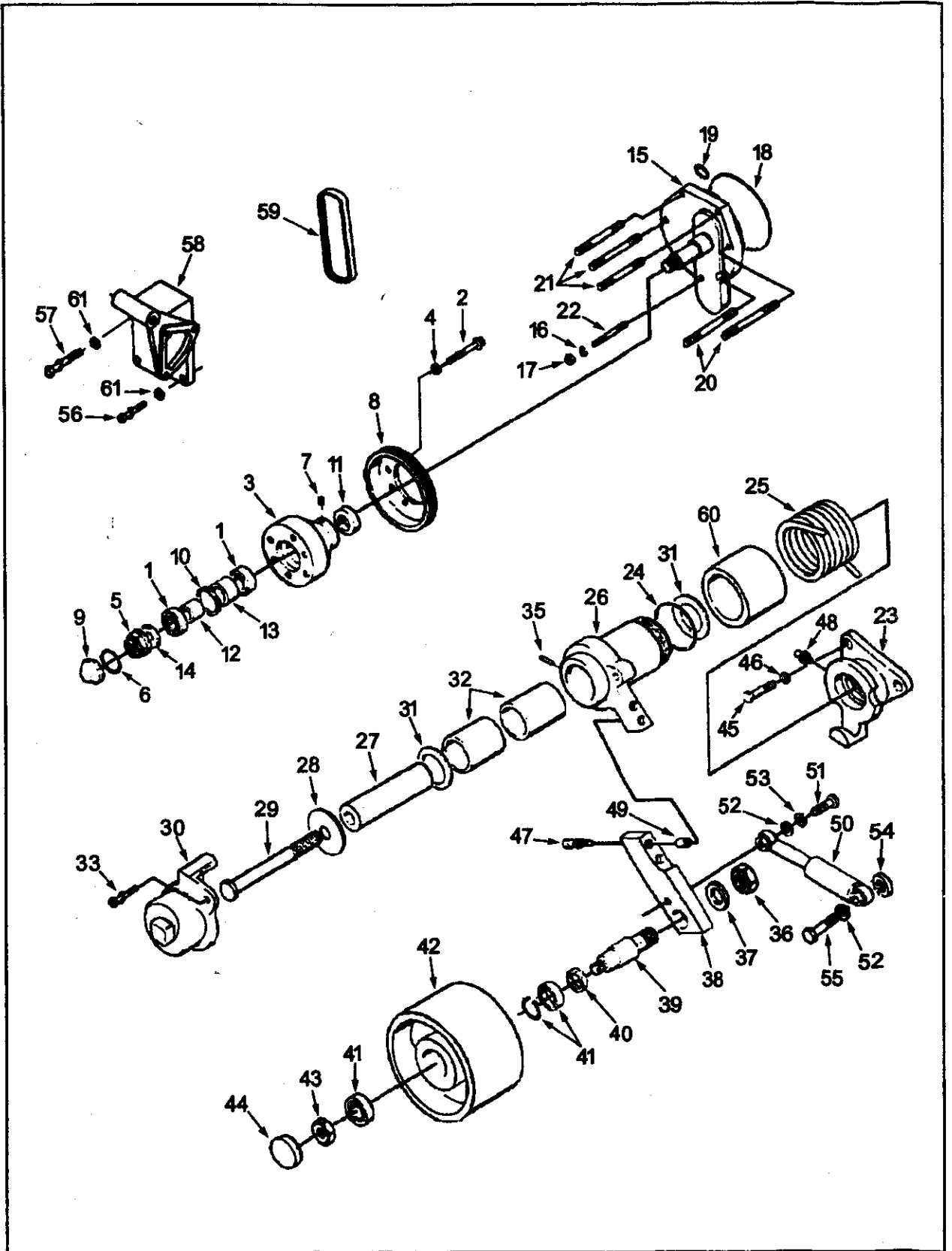

级别	零件号	图上 标号	零件名称		数量	备注
			中文	英文		
02	3033957		风扇张紧轮杆	LEVER, IDLER	1	
03	68171	35	园柱销	PIN, ROLL	2	
03	127454	28	平垫圈	WASHER, PLAIN	1	
03	145581	24	O型圈	SEAL, O RING	1	
03	3009475	27	导向轴	SHAFT, PIVOT	1	
03	3009477	32	隔套	SLEEVE	2	
03	3012481	29	六角螺栓	SCREW, HEXAGON HEAD	1	
03	3019415	25	拉紧弹簧	SPRING, TORSION	1	
03	3023499	30	盖子	CAP, IDLER LEVER	1	
03	3177125	23	支架	SUPPORT, PIVOT SHAFT	1	
03	3177127	26	惰轮杆	LEVER, IDLER	1	
03	3177128	60	耐磨套	SLEEVE, WEAR	1	
03	3177129	31	止推轴承	BEARING, THRUST	2	
03	S 110	B 33	六角螺栓	SCREW, HEXAGON HEAD	1	
03	S 2268	48	黄油嘴	FITTING, GREASE	1	
02	3009639		张紧轮	PULLEY, IDLER	1	
03	3003353	40	油封	SEAL, OIL	1	
03	3003354	41	滚动轴承	BEARING, ROLLER	1	
03	3004057	43	锁紧螺母	NUT, LOCK	1	
03	3009481	39	惰轮轴	SHAFT, IDLER	1	
03	3042651	38	张紧轮支架	BRACKET, IDLER	1	
03	3201206	44	碗型塞	PLUG, EXPANSION	1	
03	3201228	42	张紧轮	PULLEY, IDLER	1	
03	S 249	36	六角螺母	NUT, REGULAR HEXAGON JAM	1	
03	S 640	37	平垫圈	WASHER, PLAIN	1	
02	3016738		风扇张紧轮安装	IDLER, FAN MTG	1	
03	103009	45	六角螺栓	SCREW, HEXAGON HEAD CAP	3	
03	3002993	49	定位环	DOWEL, RING	2	
03	3012475	47	带垫螺栓	SCREW, CAPTIVE WAS	2	
03	S 610	46	弹簧垫圈	WASHER, LOCK	3	
02	3012628		发电机支架	SUPPORT, ALTERNATOR	1	
03	3010596	56	带垫圈螺栓	SCREW, CAPTIVE WAS	2	
03	3010597	57	带垫螺栓	SCREW, CAPTIVE WAS	2	
03	3041859	58	发电机支架	SUPPORT, ALTERNATOR	1	
02	3002202	59	多槽皮带	BELT, V RIBBED	1	

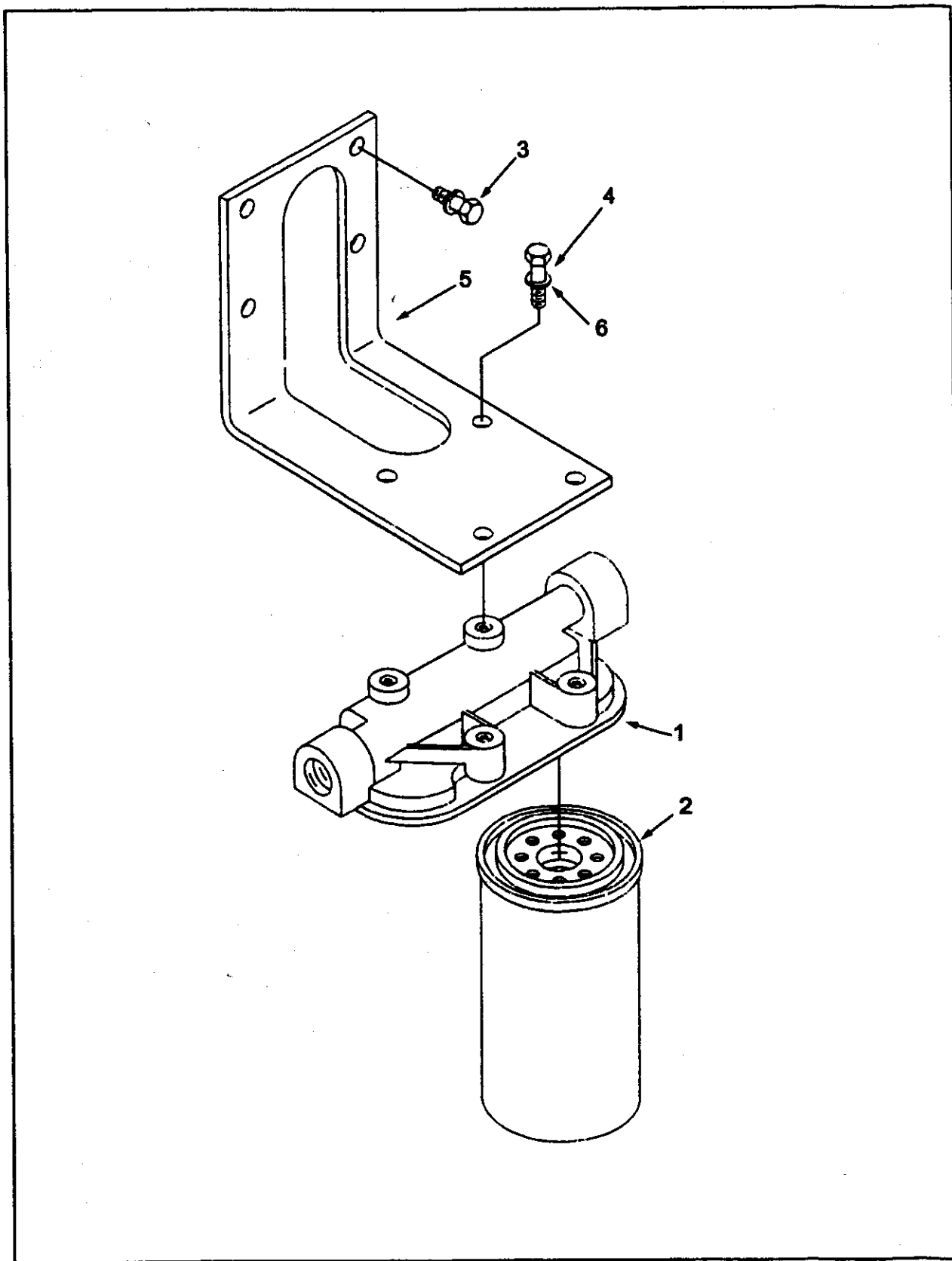

燃油滤清器

级别	零件号	图上 标号	零件名称		数量	备注
			中文	英文		
02	AR13274		燃油滤清器	FILTER,FUEL	1	
03	3315843	2	燃油滤清器	FILTER,FULE	2	
03	3418763	1	燃油座	HEAD,FUEL FILTER	1	
02	MP45194		燃油滤清器支架安装	BRACKET,FUEL FILTER MTG	1	
03	3201394	5	滤清器支架	BRACKET,FILTER	1	
03	S 103 D	4	六角螺栓	SCREW,HEXAGON HEAD CAP	4	
03	S 120	3	六角螺栓	SCREW,HEXAGON HEAD CAP	4	
03	S 604	6	弹簧垫圈	WASHER,LOCK	8	

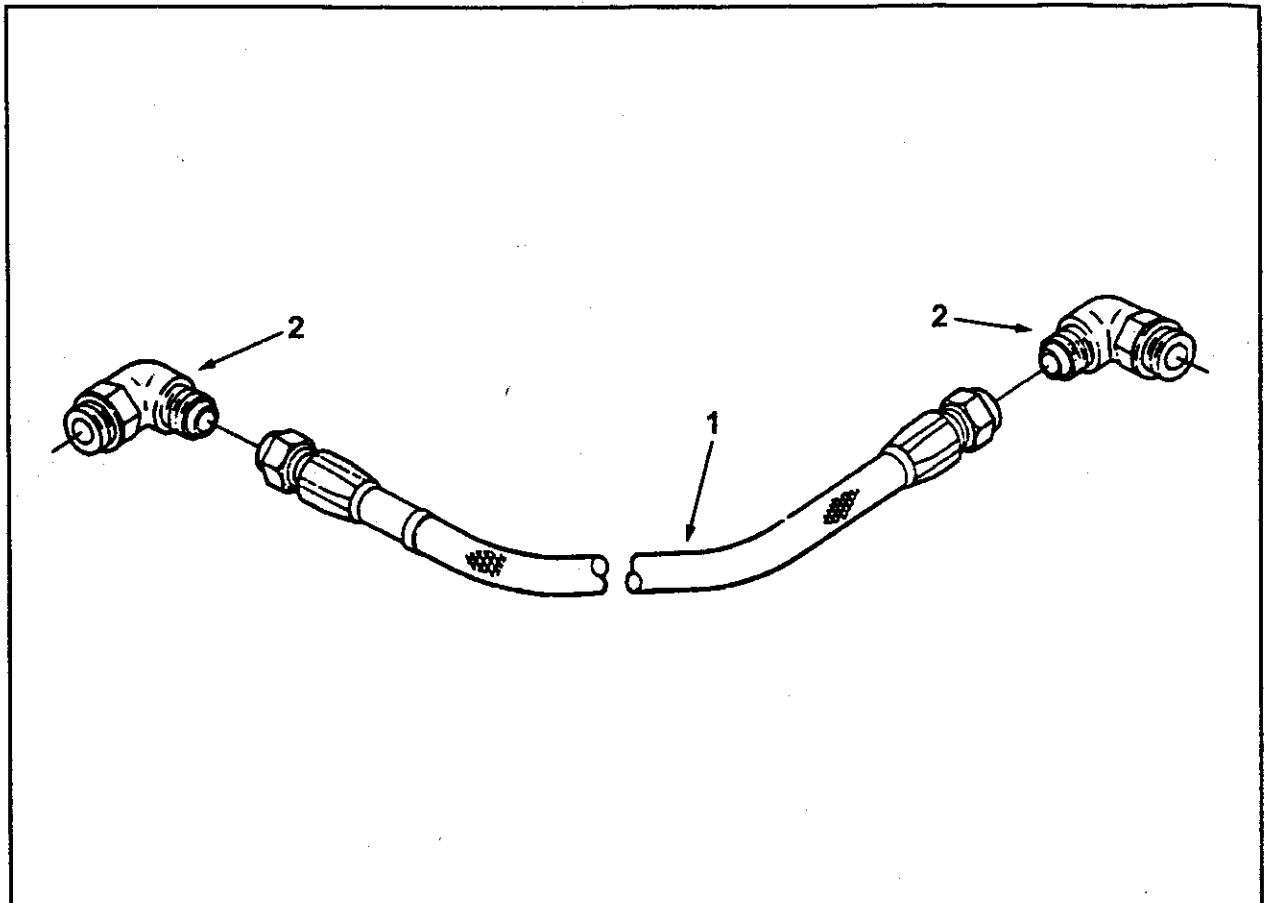

级别	零件号	图上 标号	零件名称		数量	备注
			中文	英文		
02	129859	2	联接管弯头	ELBOW,MALE UNION	1	
02	129866	3	阳性接头	UNION,MALE	1	
02	AS10018 SS	1	软管	HOSE,FLEXIBLE	1	

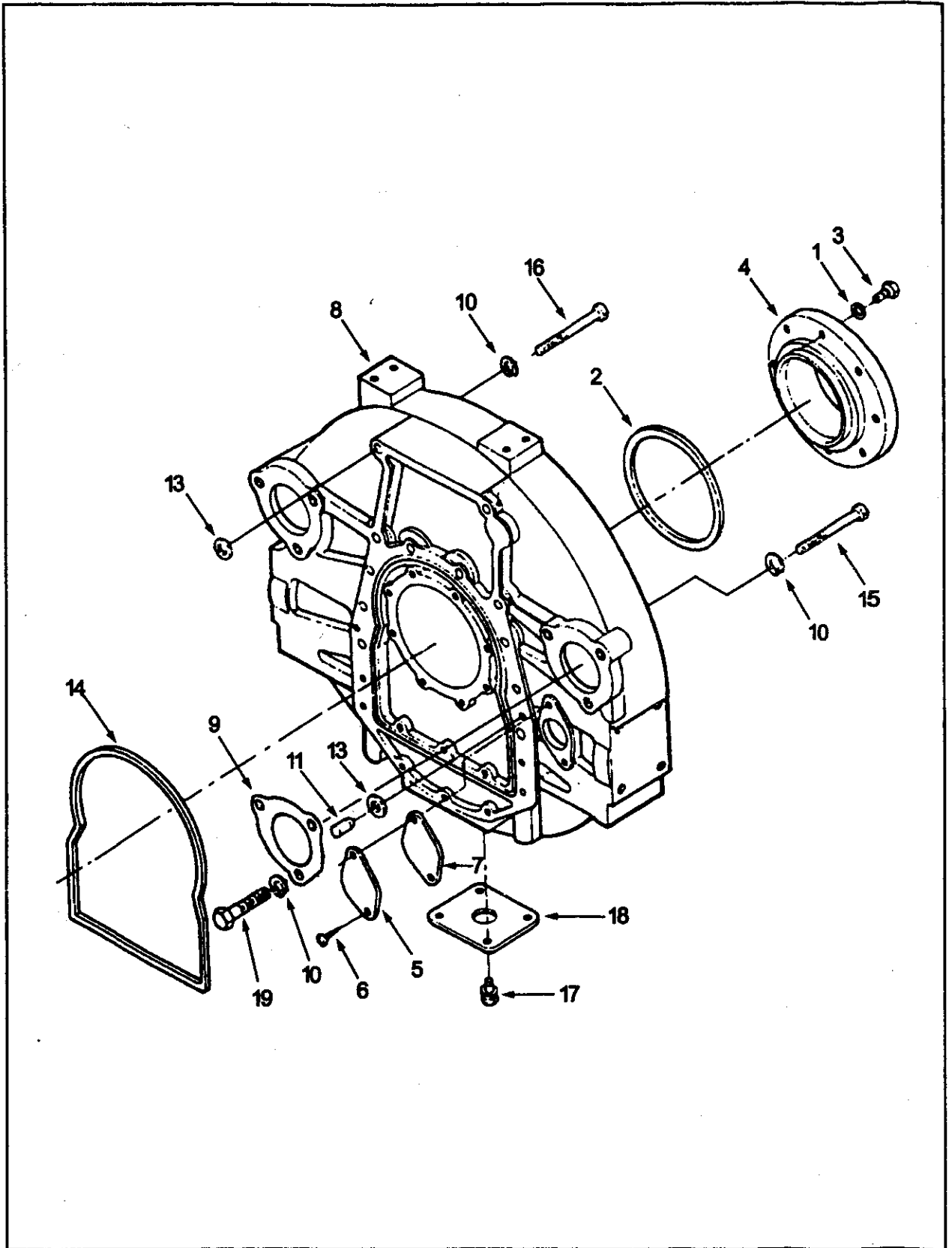

级别	零件号	图上 标号	零件名称		数量	备注
			中文	英文		
02	AR10591		曲轴后油封	SEAL,REAR OIL CRANKSHAFT	1	
03	S 631	1	平垫圈	WASHER,PLAIN	8	
03	205247	2	O型密封圈	SEAL,O RING	1	
03	205409	3	六角螺栓	SCREW,HEXAGON HEAD CAP	8	
03	3160925	4	曲轴后油封	SEAL,OIL RR CRK	1	
02	3036814	8	飞轮壳	HOUSING,FLYWHEEL	1	
02	3028968		飞轮壳安装	HOUSING,FLYWHEEL MTG	1	
03	9226	11	飞轮壳定位销	DOWEL,FLYWEEL HOUSING	2	
03	172648	13	矩形圈	SEAL,RECTANGULAR RING	14	
03	3096260	14	矩形密封圈	SEAL,RECTANGULAR RING	1	
03	S 103	A 15	六角螺栓	SCREW,HEXAGON HEAD	10	
03	S 144	16	六角螺栓	SCREW,HEXAGON HEAD	2	
03	S 603	10	弹簧垫圈	WASHER,LOCK	12	
02	3201078		飞轮壳盖及安装	COVER,FLYWEEL HOUSING	1	
03	3201056	18	飞轮壳盖	COVER,FLYWEEL HOUSING	1	
03	S 109	17	六角螺栓	SCREW,HEXAGON HEAD CAP	4	
03	S 604		弹簧垫圈	WASHER,LOCK	4	
02	3005083		起动机孔盖安装组件	COVER,INDEX HOLE MTG	1	
03	70657	5	飞轮指示孔盖	COVER,FLYWEEL INDEX HOLE	1	
03	3011342	6	带垫螺栓	SCREW,CAPTIVE WASHER	2	
03	3021735	7	衬垫	GASKET,FLYWHEEL HSG	1	
02	MP 5044		起动机孔盖	COVER,STARTER HOLE	1	
03	62182	9	起动机发兰盖板	COVER,STARTER FIANGE	1	
03	S 181	19	六角螺栓	SCREW,HEXAGON HEAD CAP	3	
03	S 603	10	弹簧垫圈	WASHER,LOCK	3	

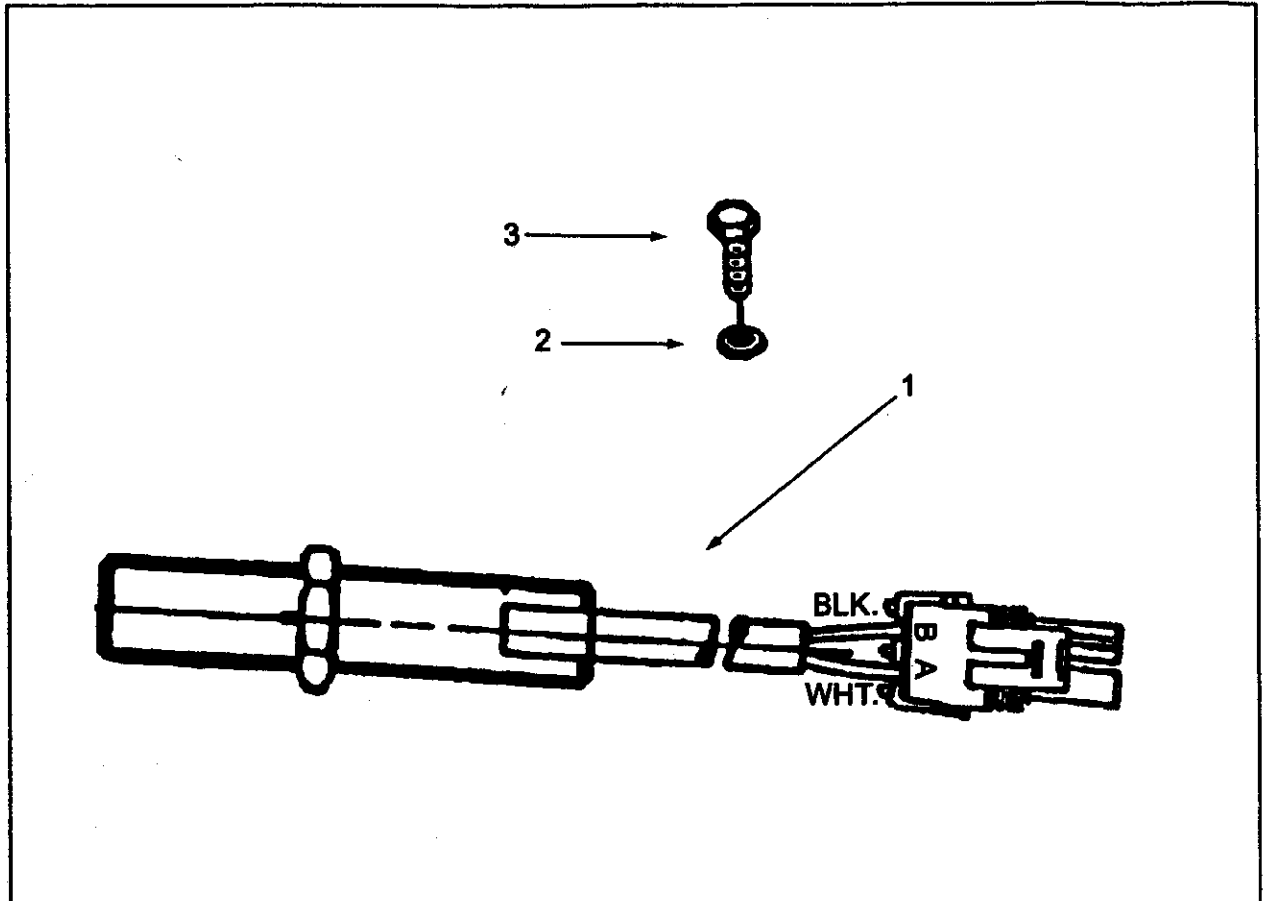

级别	零件号	图上 标号	零件名称		数量	备注
			中文	英文		
02	3034572	1	电磁传感器	PICKUP,MAGNETIC	1	
02	3201959		传感器孔堵塞	PLUG,MAG PICK-UP HOLE	1	
03	553856	2	衬垫	GASKET,DRAIN PLUG	1	
03	3201759	3	六角螺栓	SCREW,HEXAGON HEAD CAP	1	

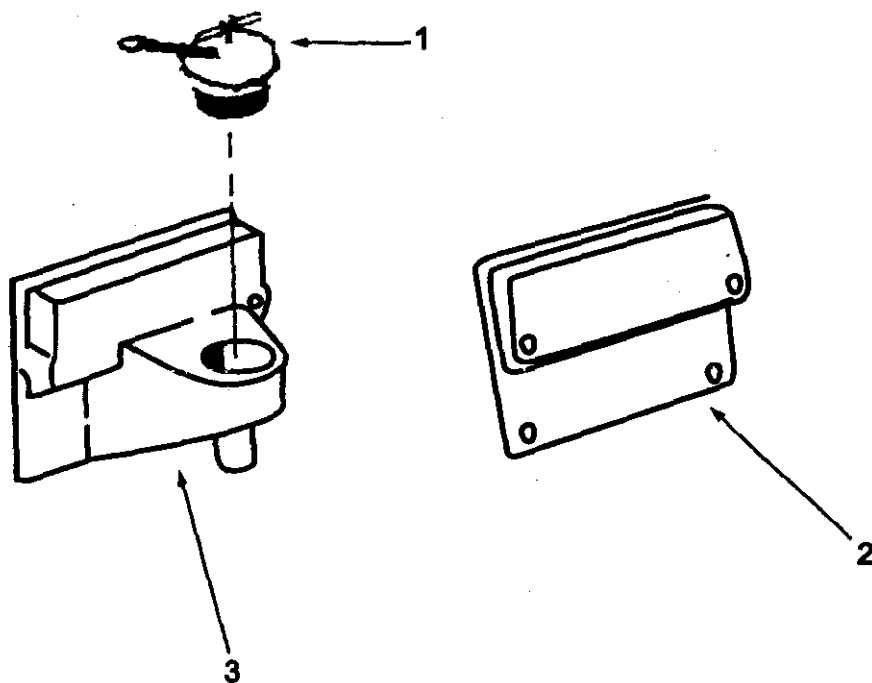

级 别	零 件 号	图 上 标 号	零 件 名 称		数 量	备 注
			中 文	英 文		
02	3418519	1	加机油口盖总成	CAP FILLER	1	
02	3628755	2	凸轮从动件盖	COVER CAMSHAFT	1	
02	3200414 CE		凸轮轴从动件盖	COVER,CAM FOLLOWER	1	
03	101264		加机油口管	TUBE,OIL FILLER	1	
03	3418880	3	机油管托架	BRACKET,OIL TUBE	1	

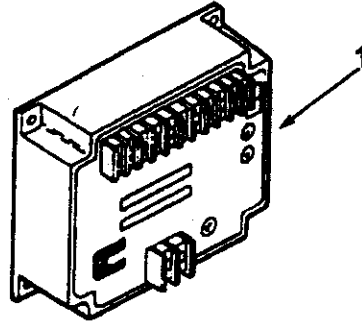

级别	零件号	图上 标号	零件名称		数量	备注
			中文	英文		
02	3044196	1	远程电子调速器	CONTROL,GOVERNOR	1	

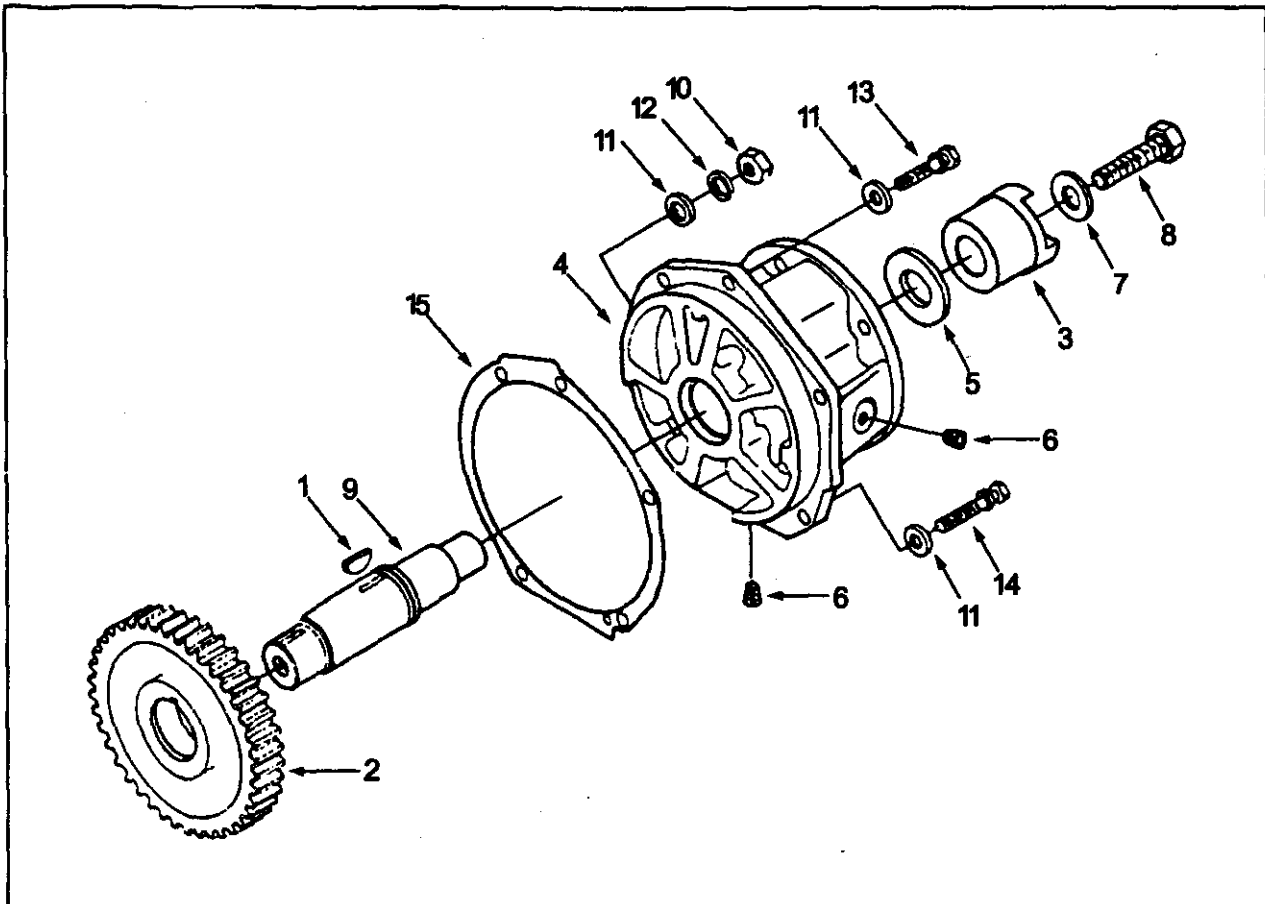

级别	零件号	图上 标号	零件名称		数量	备注
			中文	英文		
02	3016734		辅助驱动装置	DRIVE,ACCESSORY	1	
03	S 316	1	半园键	KEY,PLAIN WOODRUFF	1	
03	207253	2	辅助传动齿轮	GEAR,ACCESSORY DRIVE	1	
03	3000175	3	燃油泵传动轴接合爪	HUB,JAW COUPLING	1	
03	3009512	4	辅助驱动支承	SUPPORT,ACCESSORY DRIVE	1	
03	3014103	5	挡圈	WASHER,PLAIN	1	
03	3025460	6	管塞	PLUG,PIPE	2	
03	3045136	7	平垫圈	WASHER,PLAIN	1	
03	3045137	8	六角螺栓	SCREW,HEXAGON HEAD	1	
03	3045229	9	附件驱动轴	SHAFT,ACCESSORY DRIVE	1	
02	3017472		附件驱动安装	DRIVE,ACCESSORY MTG	1	
03	3044413	14	带垫螺栓	SCREW,CAPTIVE WASHER	1	
03	3201693	15	附件驱动支架衬垫	GASKET,ACC DRIVE SUPPORT	1	
03	S 120	13	六角螺栓	SCREW,HEXAGON HEAD CAP	3	
03	S 205	10	六角螺母	NUT,REGULAR HEXAGON	1	
03	S 602	11	平垫圈	WASHER,PLAIN	5	
03	S 604	12	弹簧垫圈	WASHER,LOCK	1	

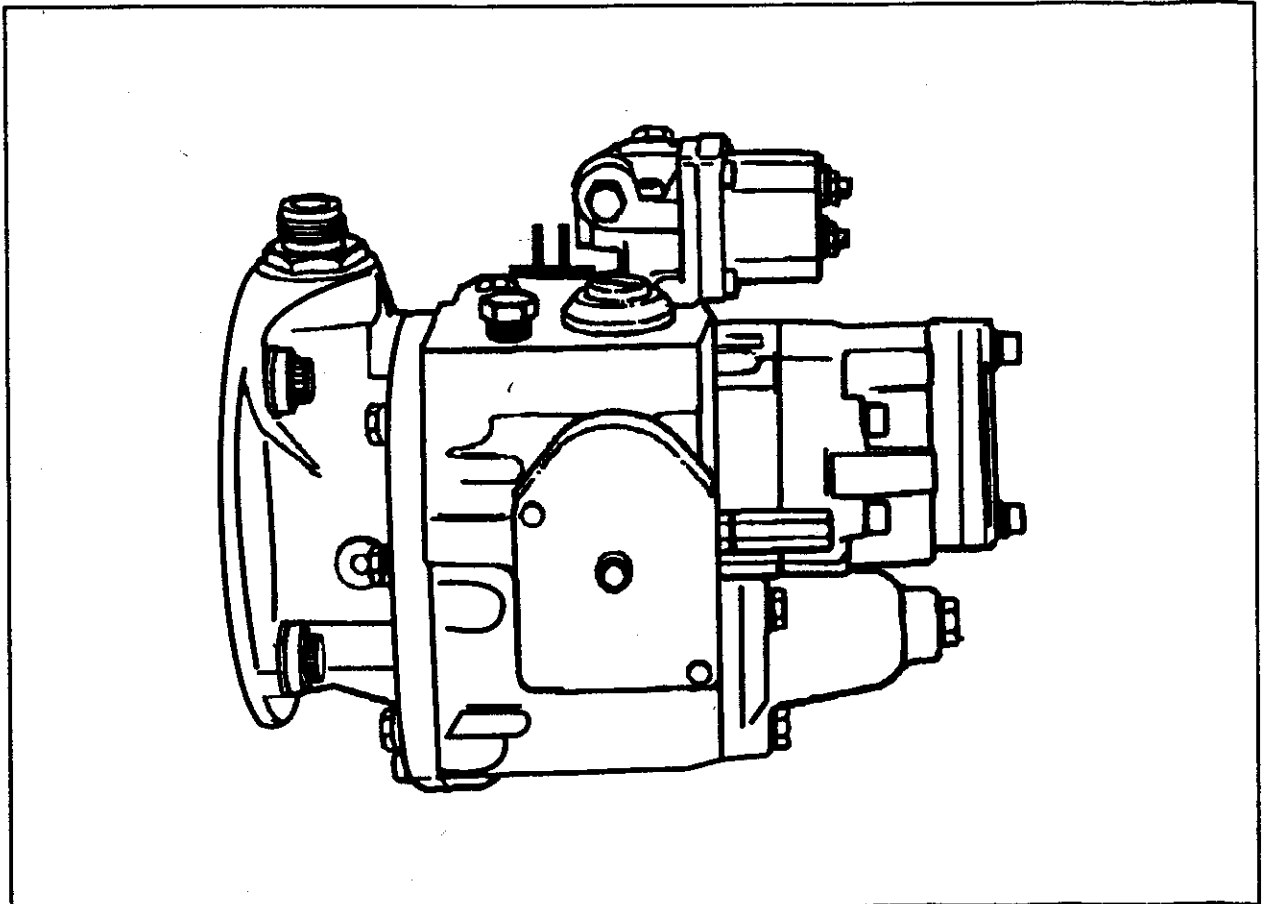

级别	零件号	图上 标号	零件名称		数量	备注
			中文	英文		
02	3655654		燃油泵总成(T.L.N.)	FUEL PUMP (T.L.N.)	1	G3
02	3655993		燃油泵总成(T.L.N.)	FUEL PUMP (T.L.N.)	1	G4

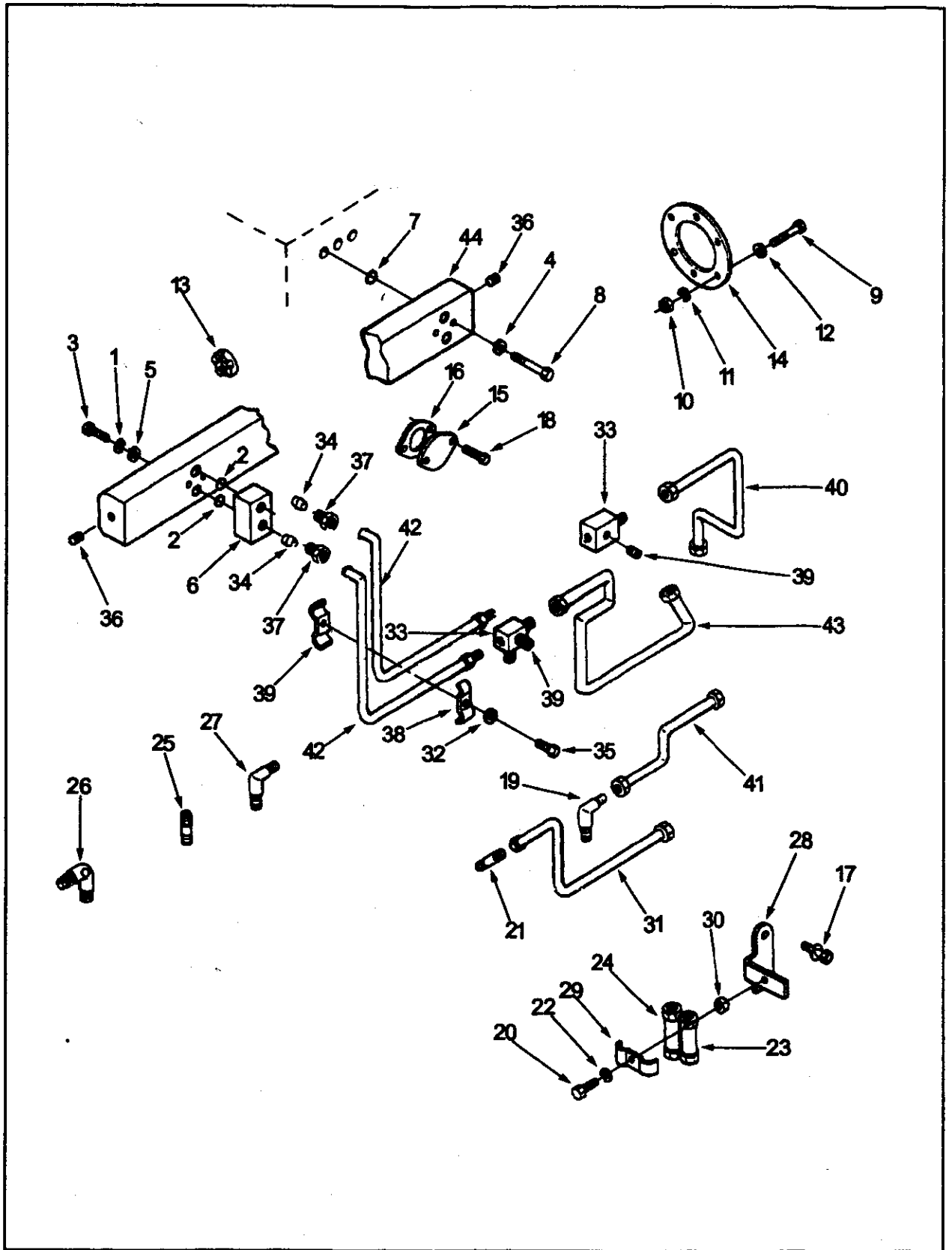

级别	零件号	图上 标号	零件名称		数量	备注
			中文	英文		
02	AR45224		燃油歧管	MANIFOLD,FUEL	1	
03	100478	2	O型圈	SEAL,O RING	2	
03	118226	3	内六角螺栓	SCREW,SOCKET HEAD CAP	2	
03	127018	4	平垫圈	WASHER,PLAIN	12	
03	128006	5	平垫圈	WASHER,PLAIN	2	
03	207441	44	燃油歧管	MANIFOLD,FUEL	1	
03	207442	6	燃油管路联接	CONNECTION,FUEL BLOCK	1	
03	3001340	7	O型密封圈	SEAL,O RING	12	
03	3001811	8	十二角螺栓	SCREW,TWELVE POINT CAP	12	
03	S 607	1	弹簧垫圈	WASHER,LOCK	2	
02	MP 5015		燃油泵安装	PUMP,FUEL MTG	1	
03	69324	12	平垫圈	WASHER,PLAIN	4	
03	3046200	13	爪式联轴节缓冲片	SPIDER,JAW COUPLING	1	
03	3069103	14	燃油泵衬垫	GASKET,FUEL PUMP	1	
03	S 140	9	六角螺栓	SCREW,HEXAGON HEAD	4	
03	S 217	10	六角厚螺母	NUT,HEAVY HEXAGON	4	
03	S 610	11	弹簧垫圈	WASHER,LOCK	4	
02	3065823		单向阀和支架安装	CHECK VALVES & MTG	1	
03	70704	22	垫圈	WASHER,PLAIN	1	
03	178079	23	单向阀	VALVE,CHECK	1	
03	185505	24	单向阀	VALVE,CHECK	1	
03	3010595	17	带垫螺栓	SCREW,CAPTIVE WAS	2	
03	3200069	28	单向阀支架	BRACKET,CHECK VALVE	1	
03	3200070	29	单向阀支架	BRKT,CHECK VLV	1	
03	3201614	30	隔套	SPACER,MOUNTING	1	
03	3419023	25	管接头	UNION,MALE	1	
03	3419031	26	弯接头	ELBOW,MALE UNION	1	
03	3419032	27	弯接头	ELBOW,MALE UNION	1	
03	S 156	B 20	六角螺栓	SCREW,HEXAGON HEAD	1	
02	68138	21	阳性管接头	CONNECTOR,MALE	1	
02	116936	19	普通弯管接头	BLBOW,PLAIN ADAPT	1	
02	3165728	31	燃油管	TUBE,FUEL SUPPLY	1	
02	3165734	40	供油管	TUBE,FUEL SUPPLY	1	
02	3165735	43	供油管	TUBE,FUEL DRAIN	1	
02	3165740	42	燃油供油管	TUBE,FUEL SUPPLY	2	
02	3200425	41	回油管	TUBE,FUEL DRAIN	1	

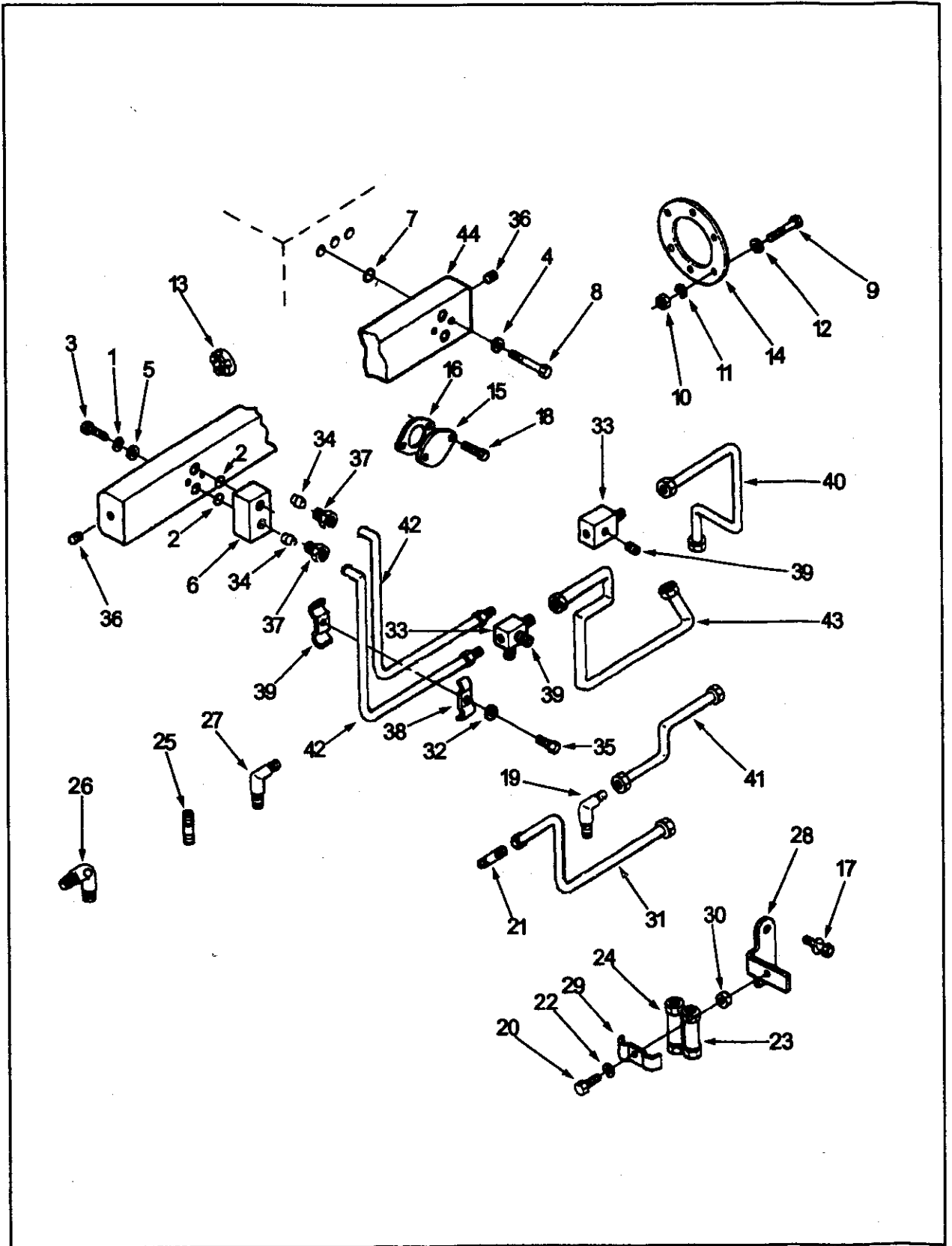

级别	零件号	图上 标号	零件名称		数量	备注
			中文	英文		
02	4062487		燃油管安装	FUEL,TUBE MOUNTING	1	
03	127362	32	平垫圈	WASHER,PLAIN	2	
03	3012478	35	带垫螺栓	SCREW,CAPTIVE WASHER	2	
03	3025460	36	管塞	PLUG,PIPE	2	
03	3031404	37	油管接头	CONNECTOR,TUBE	2	
03	3165842	33	三通接头	TEE,FEMLE ADAPTER	2	
03	3200386	38	油管卡箍	CLAMP,TUBE	2	
03	3200387	39	油管卡箍	CLAMP,TUBE	2	
03	3633046	34	O型密封圈	SEAL,FRRULE	2	
02	MP 5132		空压机进水法兰	FLANGE,COMP WTR INLET	1	
03	207112	15	焊接法兰	FLANGE,WELD	1	
03	207117	16	空压机衬垫	GASKET,AIR COMPRE	1	
03	3014766	18	带垫螺栓	SCREW,HEXAGON HEAD CAP	2	
03	S 606	A	弹簧垫圈	WASHER,LOCK	2	

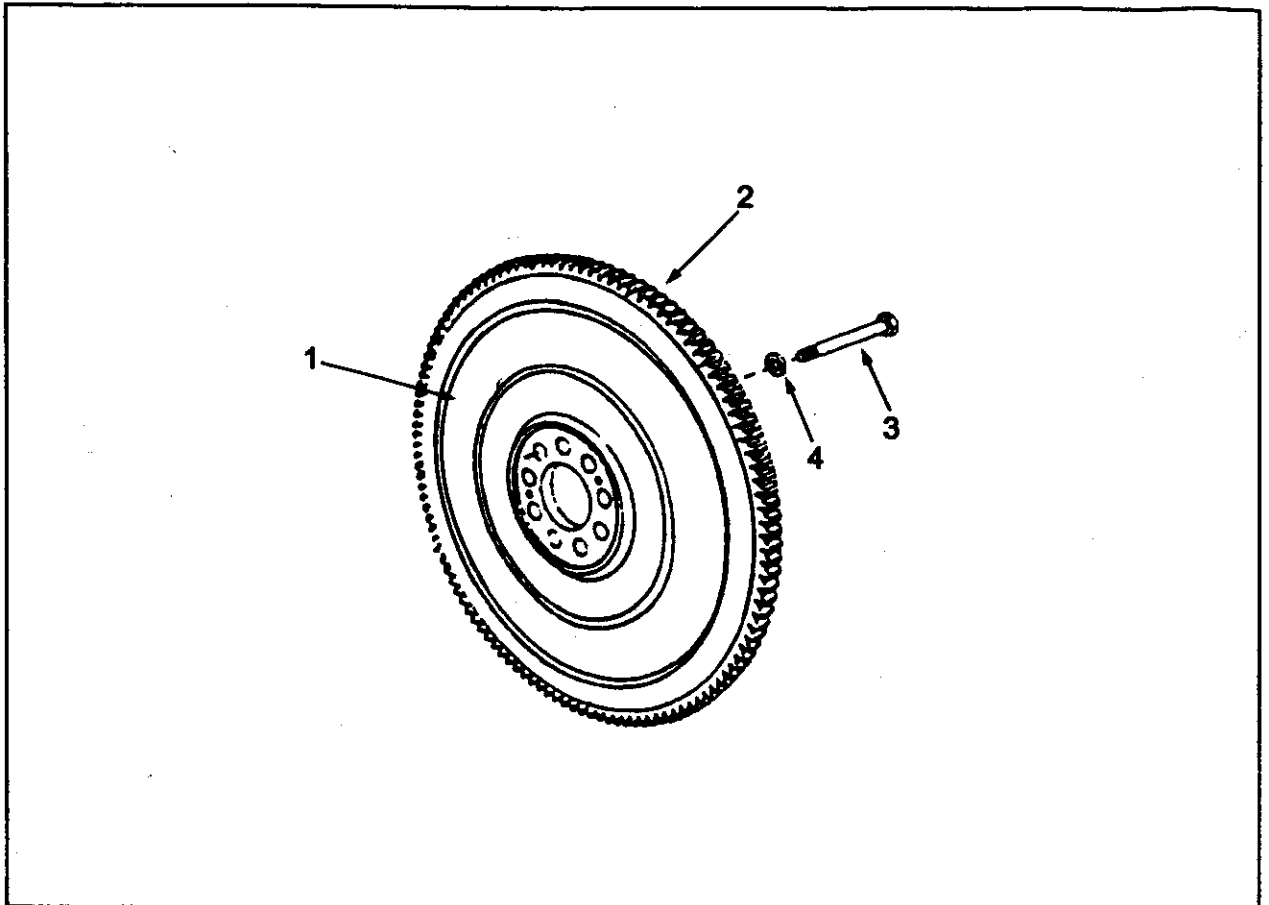

级别	零件号	图上 标号	零件名称		数量	备注
			中文	英文		
02	3024105		飞轮总成	FLYWHEEL	1	
03	5566	1	飞轮齿圈	GEAR FLYWHEEL	1	
03	3005581	2	飞轮	FLYWHEEL	1	
02	MP 4980		飞轮安装	FLYWHEEL,MTG	1	
03	200861	4	平垫圈	WASHER,PLAIN	9	
03	207386	3	螺栓	SCREW,HEAD LOCKIN	9	

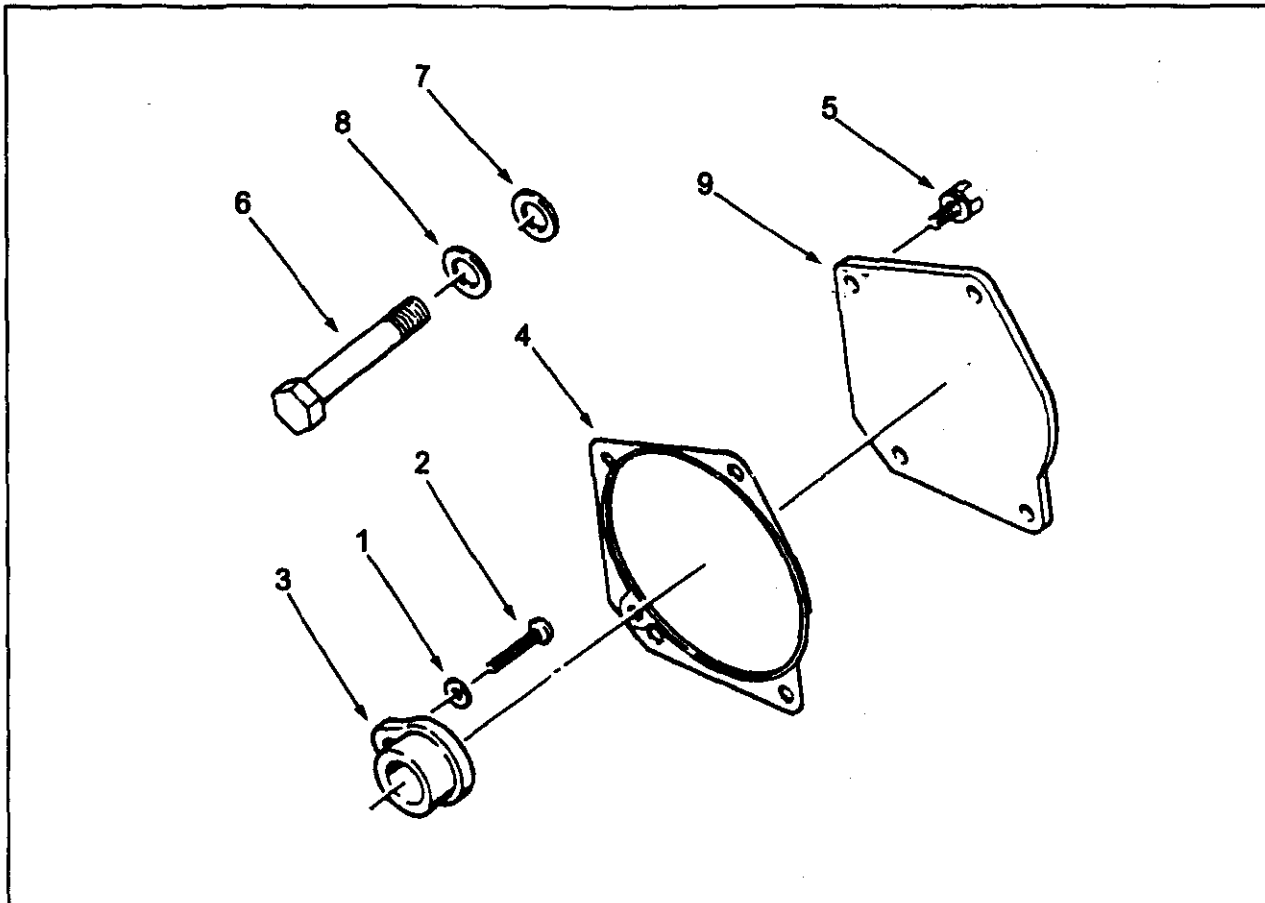

级别	零件号	图上 标号	零件名称		数量	备注
			中文	英文		
02	MP45143		转向泵镶套总成	INSERT,PUMP DRIVE	1	
03	S 602	1	平垫圈	WASHER,PLAIN	1	
03	129510	2	六角螺栓	SCREW,HEXAGON HEAD CAP	1	
03	3003123	3	镶套	INSERT,PUMP DRIVE	1	
02	3016724		后液压泵盖安装	COVER,REAR HYD MO	1	
03	3007380	4	液压泵衬垫	GASKET,HYDRAULIC	1	
03	3012472	5	带垫圈螺栓	SCREW,CAPTIVE WASHER CAP	4	
02	3017932		惰轮孔塞安装件	IDLER,HOLE PLUG MTG	1	
03	S 123	A 6	六角螺栓	SCREW,HEXAGON HEAD	1	
03	3017346	7	平垫圈	WASHER,PLAIN	1	
03	3200772	8	平垫圈	WASHER,PLAIN	1	
02	3201609	9	液压泵法兰盖	COVER,HYD PUMP FLANGE	1	

水箱连接

级别	零件号		图上 标号	零件名称		数量	备注
				中文	英文		
02	3005091			水箱连接件	RADIATOR,CONNECTION	1	
03	43828	A	6	软管卡箍	CLAMP,HOSE	4	
03	43828	E	7	软管夹箍	CLAMP,HOSE	8	
03	60985		8	软管	HOSE,PLAIN	1	
03	64978		9	软管	HOSE,PLAIN	1	
03	67369		10	软管	HOSE,PLAIN	2	
03	67369	C	11	软管	HOSE,PLAIN	2	
03	125739		14	抱箍	CLAMP,T BOLT	4	
03	143950		15	阳性接头	CONNECTOR,MALE	2	
03	200517		16	普通软管	HOSE,PLAIN	2	
03	3001356		17	出水管	TUBE,WATER OUTLET	2	
03	3004245		18	进水管	TUBE,WATER INLET	1	
03	3052360		19	水箱补偿水管	TUBE,RAD FILL ASSY	1	
03	3165997		12	放水开关	DRAINCOCK	1	
03	AS 5033	SS	3	软管	HOSE,FLEXIBLE	1	
03	S 901			管塞	PLUG,PIPE	2	
03	S 921	D	5	衬套接头	BUSHING,REDUCING PIPE	1	

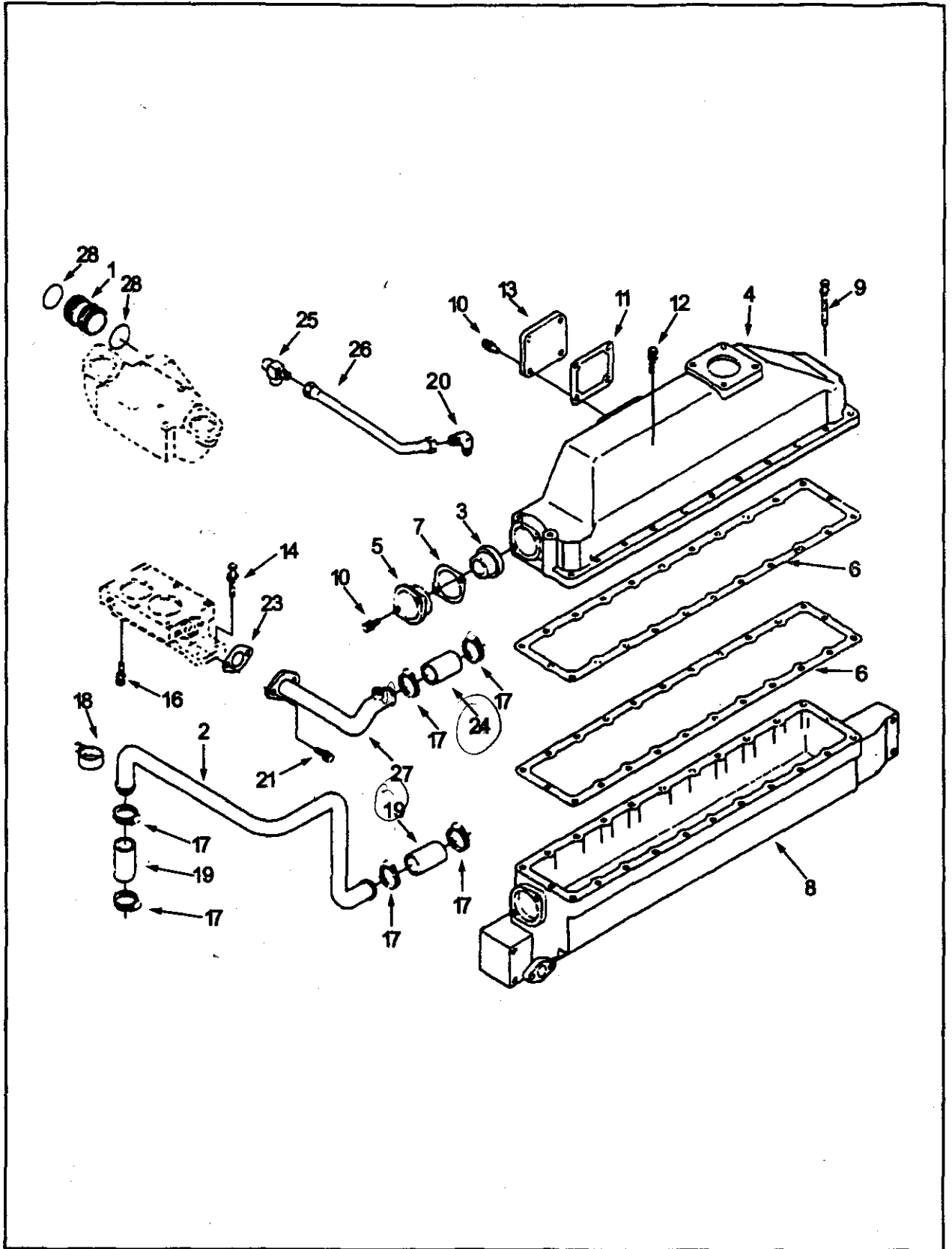

进气管

级别	零件号	图上 标号	零件名称		数量	备注
			中文	英文		
02	207378	1	输水管	TUBE,WASTER TRANSFER	1	
02	3002179	2	输水管	TUBE,WATER TRANSFER	1	
02	3009562		中冷器室盖	COVER,AFTERCOOLER HSG	1	
03	127362		平垫圈	WASHER,PLAIN	28	
03	172640	12	十二角螺栓	SCREW,TWELVE POINT CAP	21	
03	206808	3	水接头密封圈	SEAL,WATER CONNECTION	2	
03	207222	9	十二角螺栓	SCREW,TWELVE POINT CAP	3	
03	3001300	4	中冷器盖	COVER,AFTERCOOLER	1	
03	3001301	5	密封环	RETAINER,SEAL	2	
03	3001304	6	中冷器室衬垫	GASKET,AFT HOUSING	2	
03	3001305	7	水管接头衬垫	GASKET,CONNECTION	2	
03	3005594		平垫圈	WASHER,PLAIN	4	
03	3010596	10	带垫圈螺栓	SCREW,CAPTIVE WAS	8	
03	3010927	8	中冷器室	HOUSING,AFTERCOOLER	1	
03	3032161	11	衬垫	GASKET,CONN	1	
03	3200783	13	盖板	COVER,AIR INTAKE	1	
03	S 604		弹簧垫圈	WASHER,LOCK	24	
02	3016723		节温器壳支架安装	MTG,SUPPORT THERM HSG	1	
03	127362		平垫圈	WASHER,PLAIN	2	
03	3012472	16	带垫圈螺栓	SCREW,CAPTIVE WASHER CAP	2	
03	S 141	14	螺栓	SCREW,HEXAGON HEAD	2	
03	S 604		弹簧垫圈	WASHER,LOCK	2	
02	3016727		水泵进水管安装	MTG,TUBE WTR PUMP	1	
03	3010922	18	夹子	CLLP	1	
03	3026806	17	抱箍	CLAMP,HOSE	4	
03	3818271	19	软管	HOSE,PLAIN	2	
03	S 602		平垫圈	WASHER,PLAIN	1	
02	3016728		中冷器接管	CONNECTION,AFTERCOOLER	1	
03	9539	A 24	普通软管	HOSE,PLAIN	1	
03	143950		阳性接头	CONNECTOR,MALE	1	
03	144372	20	凸式弯管接头	ELBOW,MALE ADAPTER	1	
03	3010595	21	带垫螺栓	SCREW,CAPTIVE WAS	2	
03	3010926	23	法兰衬垫	GASKET,FLANGE	1	
03	3026806	17	抱箍	CLAMP,HOSE	2	
03	3175687	25	异径三通接头	TEE,STREET PIPE	1	
03	3201384	26	通气管	TUBE.VENT	1	
03	3201401	27	输水接管	CONNECTION.WATER TRANSF	1	
02	3028291	28	O型密封圈	SEAL,O RING	2	

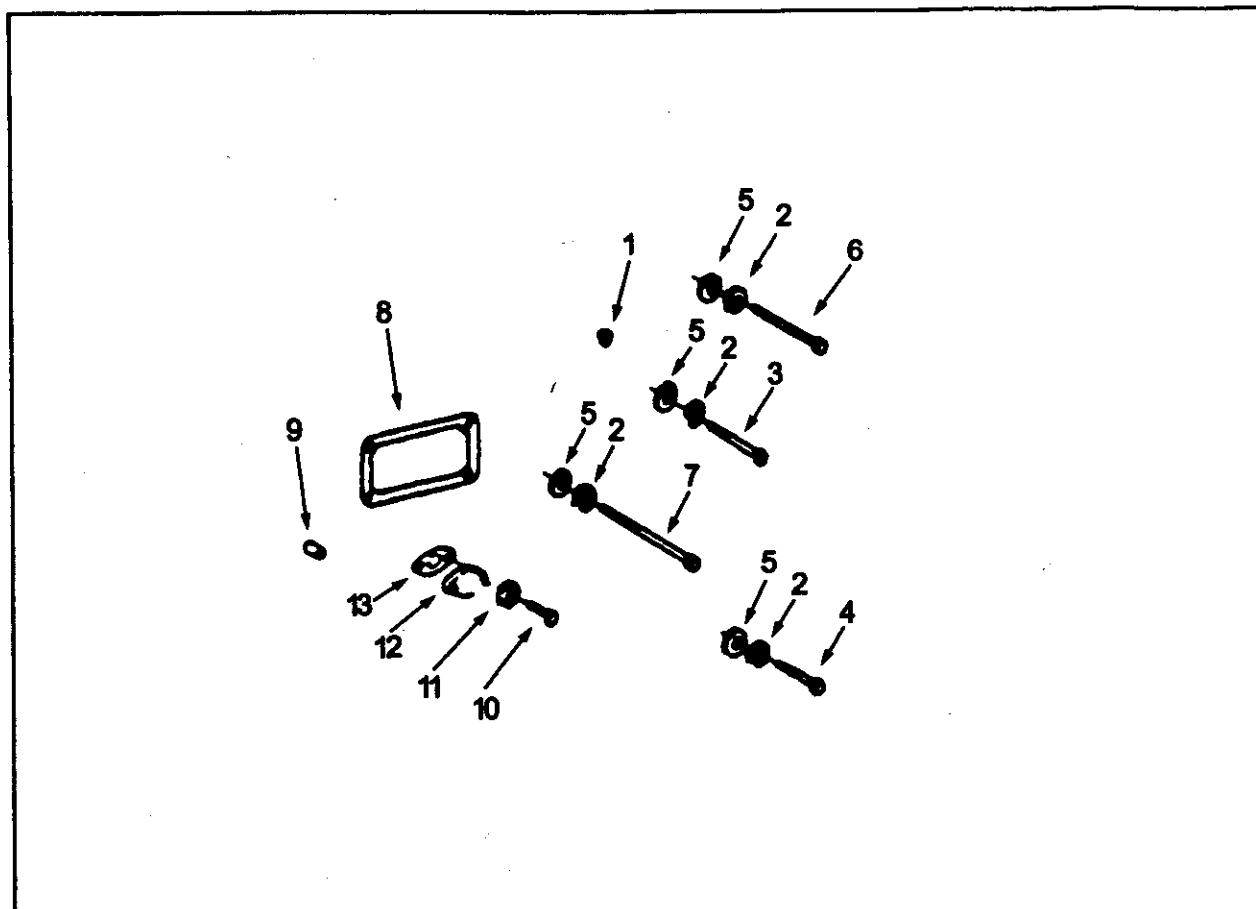

级别	零件号	图上 标号	零件名称		数量	备注
			中文	英文		
02	3008466	1	管塞	PLUG,PIPE	2	
02	3011510		中冷器室安装	MTG HOUSING AFTERCOOLER	1	
03	103271	3	六角螺栓	SCREW,HEXAGON HEAD	12	
03	123204	4	六角螺栓	SCREW,HEXAGON HEAD	2	
03	127362	5	平垫圈	WASHER,PLAIN	24	
03	137868	6	六角螺栓	SCREW,HEXAGON HEAD CAP	2	
03	137872	7	六角螺栓	SCREW,HEXAGON HEAD CAP	8	
03	206277	8	进气歧管衬垫	GASKET,AIR MANIFOLD	6	
03	3014304	9	矩形密封圈	SEAL,RECTANGULAR RING	12	
03	S 604	2	弹簧垫圈	WASHER,LOCK	24	
02	3012560		空压机盖板	COVER,AIR COMP	1	
03	3011693	12	盖板	PLATE,COVER	1	
03	3201388	13	法兰衬垫	GASKET,FLANGE	1	
03	S 103	D 10	六角螺栓	SCREW,HEXAGON HEAD CAP	2	
03	S 604	11	弹簧垫圈	WASHER,LOCK	2	

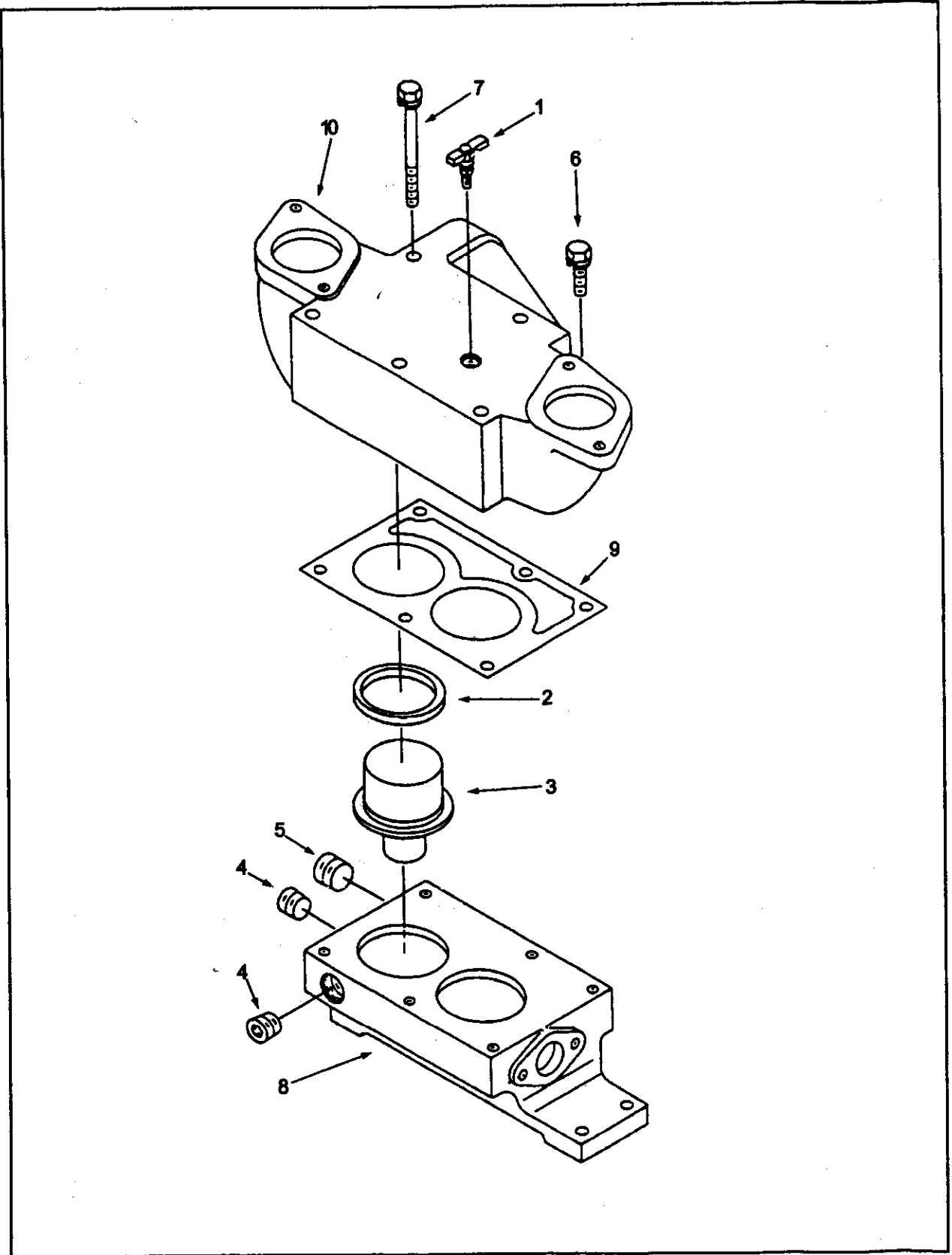

节温器壳

级别	零件号	图上 标号	零件名称		数量	备注
			中文	英文		
02	3065803		节温器壳.支架总成	THERMOSTAT HOUSING	1	
03	186780	2	节温器密封圈	SEAL,THERMOSTAT	2	
03	3008468	4	管塞	PLUG,PIPE	4	
03	3008469	5	管塞	PLUG,PIPE	2	
03	3010596	6	带垫圈螺栓	SCREW,CAPTIVE WAS	1	
03	3010597	7	带垫螺栓	SCREW,CAPTIVE WAS	5	
03	3010916	8	节温器壳体支架	SUPPORT,THERMO HSG	1	
03	3010918	9	节温器壳衬垫	GASKET,THERMOSTA	1	
03	3010933	10	节温器壳	HOUSING,THERMOSTAT	1	
03	3076489	3	节温器	THERMOSTAT	2	
03	3165998	1	放水开关	DRAINCOCK	1	

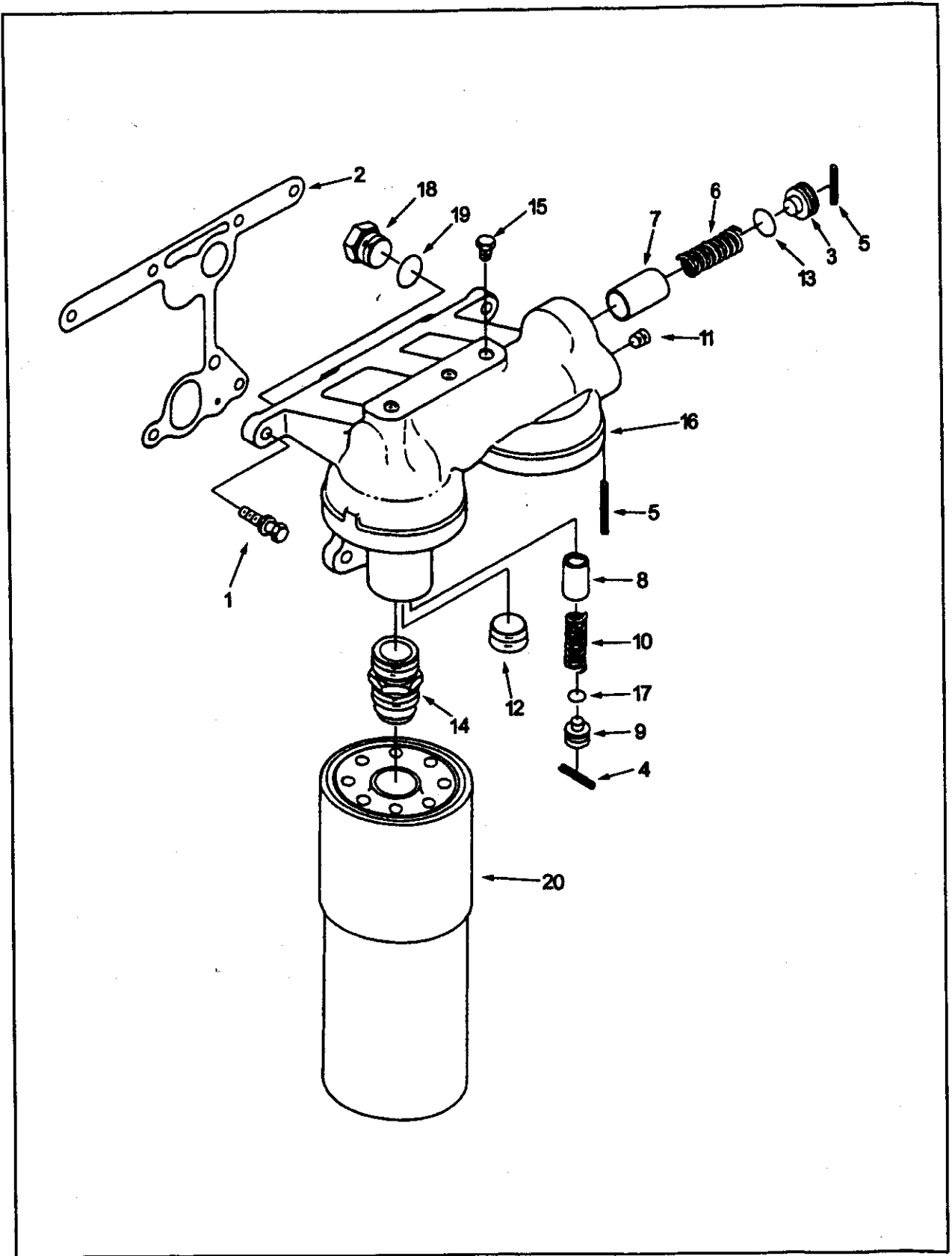

机 油 滤 清 器

级 别	零 件 号	图 上 标 号	零 件 名 称		数 量	备 注
			中 文	英 文		
02	MP 5005		机油滤清器座安装	HEAD,LUB FILFER	1	
03	3040838	1	带垫螺栓	SCREW,CAPTIVE WAS	6	
03	3200977	2	机油滤清器座衬垫	GASKET,LUB OIL FI	1	
02	3200965		机滤器座总成	LUB,OIL FILTER HEAD	1	
03	69533	3	压力调节器制动器	STOP,PRESSURERE	1	
03	161737	4	滚柱销	PIN,ROLL	1	
03	205345	5	滚柱销	PIN,ROLL	2	
03	205346	6	压缩弹簧	SPRING,COMPRESSIO	1	
03	205347	7	旁通阀柱塞	PLUNGER,BYPASS	1	
03	205348	8	活塞冷却柱塞	PLUNGER,PISTON COOLING	1	
03	205350	9	护圈塞	PLUG,RETAINER	1	
03	3007170	10	活塞冷却器弹簧	SPRING,PISTON COOL VLV	1	
03	3008466	11	管塞	PLUG,PIPE	1	
03	3008470	12	管塞	PLUG,PIPE	2	
03	3029820	13	O型密封圈	SEAL,O RING	1	
03	3034578	14	接头	ADAPTER,FILTER HEAD	2	
03	3200963		机油滤清器座	SEAL ORING	1	
04	3025458	15	管塞	LUB,OIL FILTER HEAD	3	
04	3202156	16	机油滤清器座	PLUG,PIPE	1	
03	3201125	17	O型密封圈	HEAD,LUB OIL FILTER	1	
03	3201583		螺塞	PLUG,THREADED	1	
04	3040911	18	螺塞	PLUG,THREADED	1	
04	3201585	19	O型密封圈	SEAL,O RING	1	
02	3889310	20	机油滤清器芯总成	ELEMENT,LUB OIL FILTER	2	

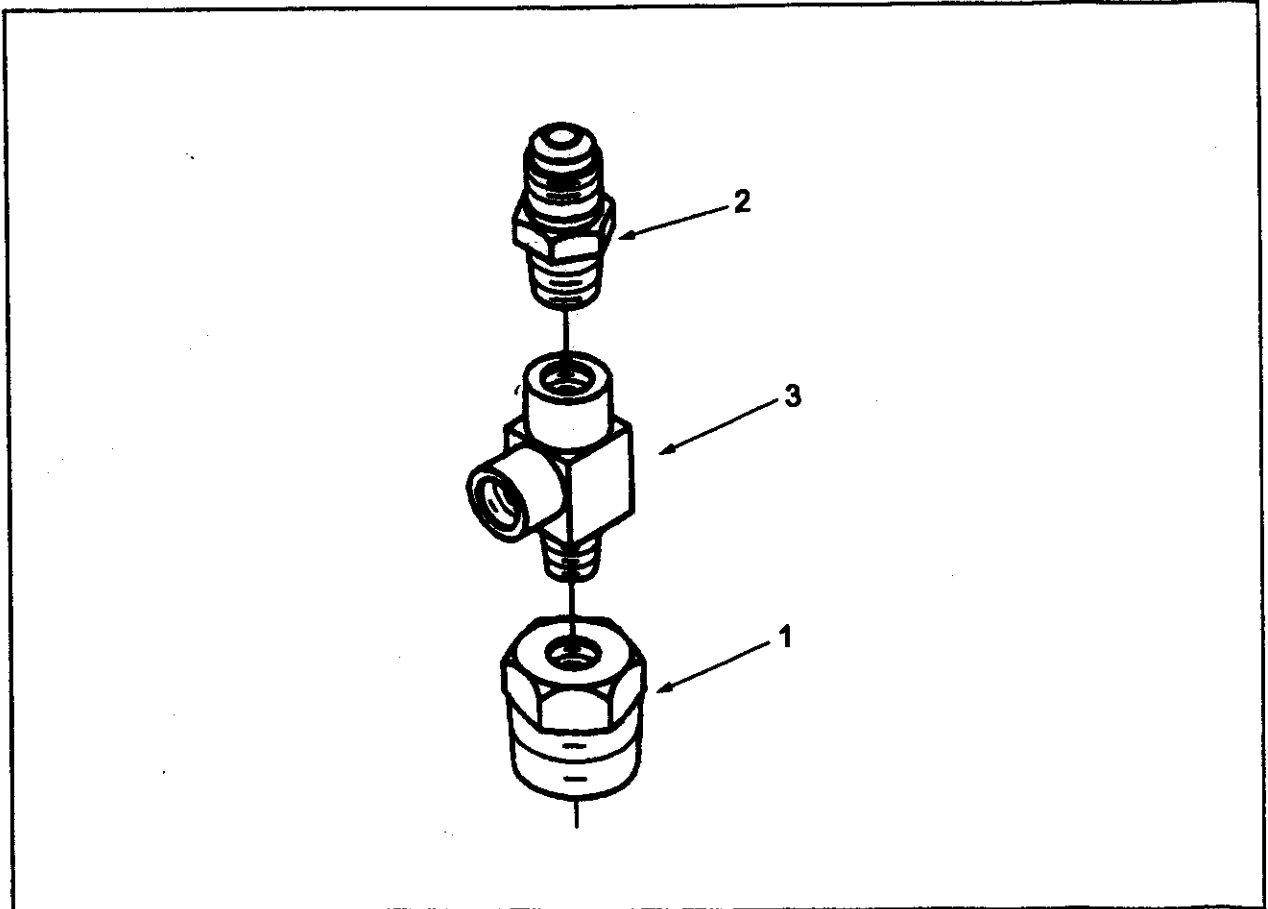

级别	零件号	图上 标号	零件名称		数量	备注
			中文	英文		
02	3175687	3	异径三通接头	TEE, STREET PIPE	1	
02	S 903 A	1	衬套	BUSHING, REDUCING PIPE	1	
02	S 1039 A	2	阳性管接头	CONNECTOR, MALE	2	

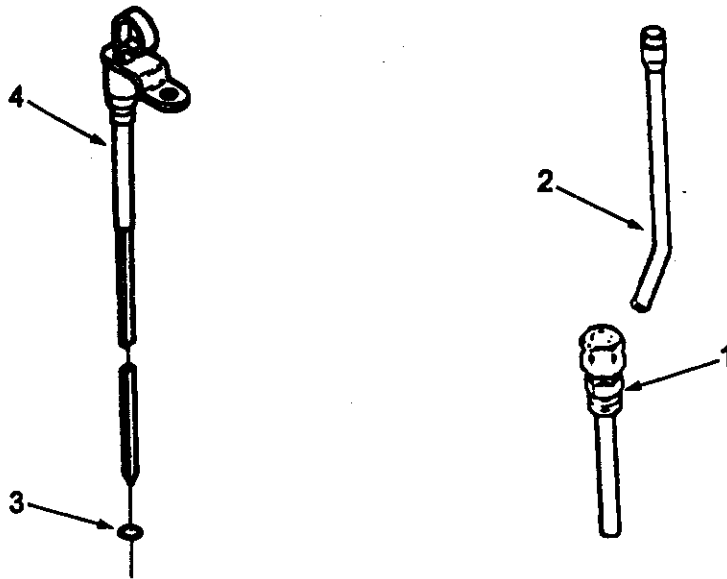

级别	零件号	图上 标号	零件名称		数量	备注
			中文	英文		
02	3419239	2	机油尺管	TUBE,OIL GAUGE	1	
02	3419241		机油尺管	TUBE,OIL GAUGE	1	
03	3046201		O型圈	SEAL,O RING	1	
03	3655211	1	机油尺管子	TUBE,OIL GAUGE	1	
02	3042083		机油尺	DIPSTICK	1	
03	108172	3	O型密封圈	SEAL,O RING	1	
03	3041136	4	机油尺	DIPSTICK	1	

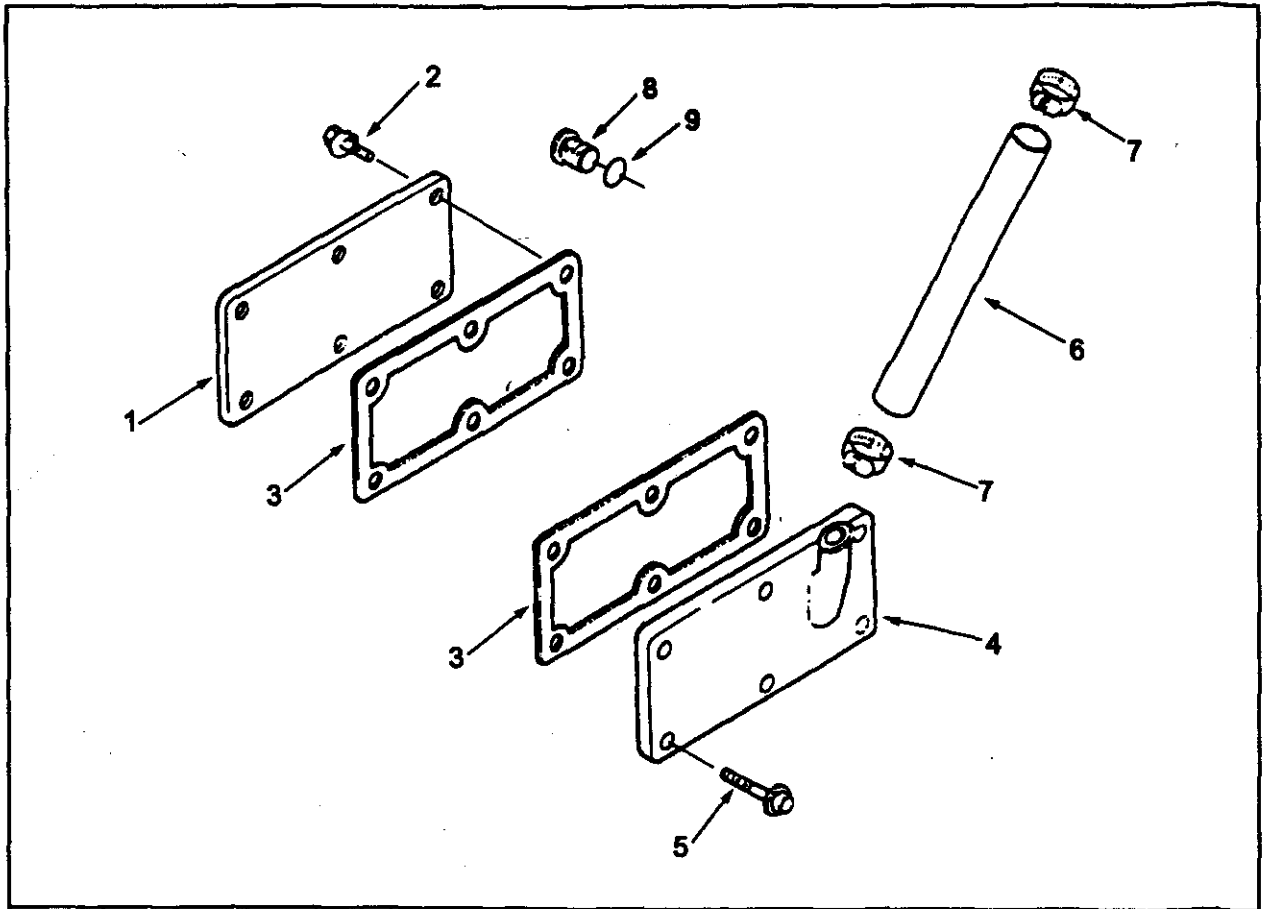

级别	零件号	图上 标号	零件名称		数量	备注
			中文	英文		
02	3201060	1	手孔盖	COVER,HAND HOLE	2	
02	3201263	4	手孔盖	COVER,HAND HOLE	1	
02	3201081		手孔盖安装	COVER,HAND HOLE MTG	2	
03	3010595	2	带垫螺栓	SCREW,CAPTIVE WAS	6	
03	3042586	3	手孔盖衬垫	GASKET,HAND HOLE	1	
02	MP 5090		盖及支架安装	COVER & BRKT MTG	1	
03	3040838	5	带垫螺栓	SCREW,CAPTIVE WASHER CAP	6	
03	3042586	3	手孔盖衬垫	GASKET,HAND HOLE	1	
02	3026806	7	抱箍	CLAMP,HOSE	2	
02	AS16020 NF	6	回油软管	HOSE,FLEXIBLE	1	
02	3046202		螺塞	PLUG,THREADED	2	
03	3040810	8	螺塞	PLUG,THREADED	1	
03	3046201	9	O型圈	SEAL,O RING	1	

机油旁通滤清器

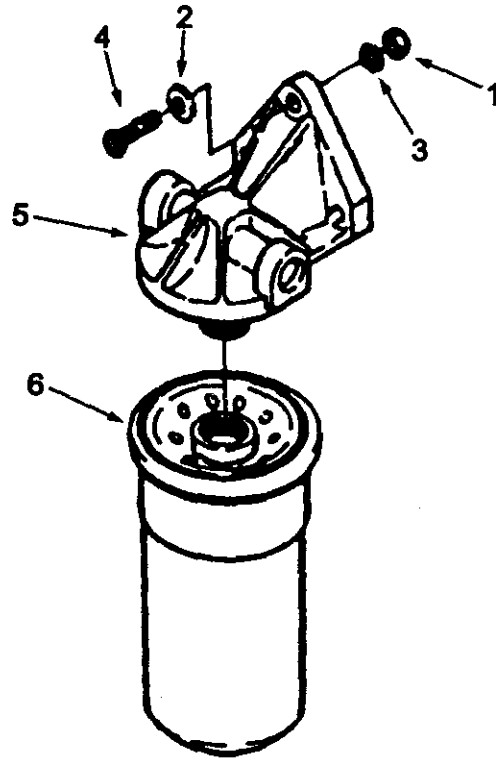

级别	零件号	图上 标号	零件名称		数量	备注
			中文	英文		
02	3035729		机油旁通滤清器安装	MTG,BYPARSS FILTER	1	
03	S 223	1	六角厚螺母	NUT,HEAVY HEXAGON	3	
03	S 604	2	弹簧垫圈	WASHER,LOCK	3	
03	108707	4	六角螺栓	SCREW,HEXAGON HEAD	3	
02	3304173	5	旁滤器座	HEAD LUB OIL FILTER	1	
02	3889311	6	旁滤清器芯	ELEMENT,LUB OIL FILTER	1	

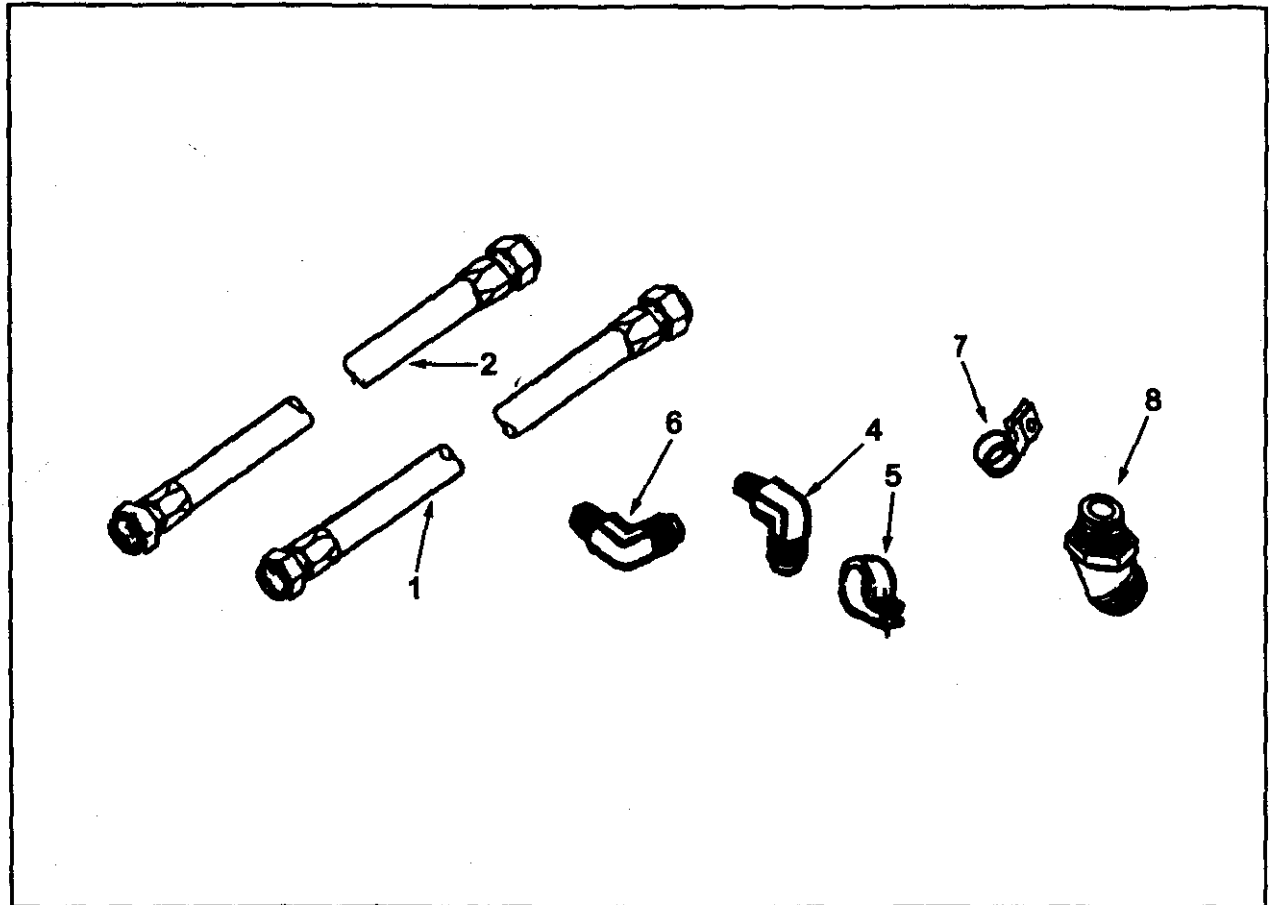

级别	零件号	图上 标号	零件名称		数量	备注
			中文	英文		
02	3059757		旁滤器安装	MTG,BYPARSS FILTER	1	
03	68645	4	阳性连接弯管	ELBOW,MALE ADAPTER	2	
03	100269	5	夹子	CLIP	3	
03	144378	6	阳性弯接头	ELBOW,MALE ADAPTER	1	
03	152767	7	管夹	CLIP,TUBE	1	
03	3175687		异径三通接头	TEE,STREET PIPE	1	
03	AS 6029 SS	1	软管	HOSE,FLEXIBLE	1	
03	AS 6050 SS	2	软管	HOSE,FLEXIBLE	1	
03	S 1039 A	8	阳性管接头	CONNECTOR,MALE	1	

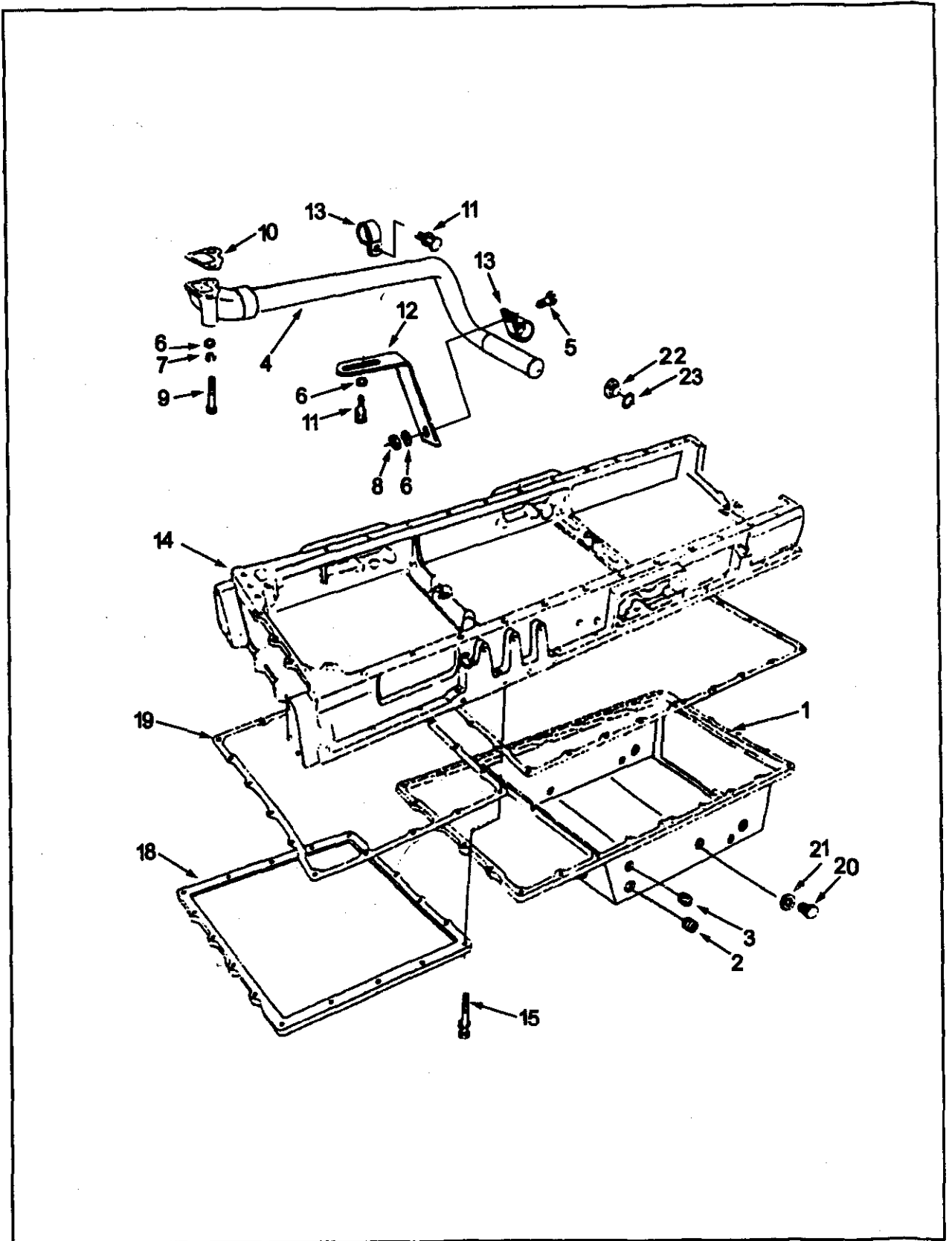

级 别	零 件 号	图 上 标 号	零 件 名 称		数 量	备 注
			中 文	英 文		
02	3011049	4	机油吸油管	TUBE,LUB OIL SUCTION	1	
02	3012087		机油管安装	TUBE,LUB OIL	1	
03	129069	8	锁紧螺母	NUT,LOCK	1	
03	137890	9	六角螺栓	SCREW,HEXAGON HEAD CAP	2	
03	3008403	10	吸油管衬垫	GASKET,OIL SUCTION	1	
03	3010593	5	带垫螺栓	SCREW,CAPTIVE WAS	1	
03	3010595	11	带垫螺栓	SCREW,CAPTIVE WAS	2	
03	3065707	12	吸油管支架	BRACE,SUCTION CONNECTION	1	
03	3200706	13	夹箍	CLIP	2	
03	S 602	6	平垫圈	WASHER,PLAIN	4	
03	S 610	7	弹簧垫圈	WASHER,LOCK	2	
02	3418862	14	机油盘联接体	ADAPTER,OIL PAN	1	
02	AR12034		机油盘总成	PAN OIL	1	
03	3008468	2	管塞	PLUG,PIPE	2	
03	3008470	3	管塞	PLUG,PIPE	2	
03	3046942		放油塞总成	PLUG,PIPE	2	
04	3046869	22	放油塞	PLUG,THREADED	1	
04	3046943	23	O型密封圈	SEAL,O RING	1	
04	3655222		磁芯	CORE	1	
03	3202152	1	机油盘	PAN OIL	1	
02	AR10695		机油盘联接体盖	COVER,OIL PAN ADAPTER	1	
03	67946		平垫圈	WASHER,PLAIN	1	
03	127362		平垫圈	WASHER,PLAIN	18	
03	207306	18	机油盘联接体盖	COVER,OIL PAN ADAPTER	1	
03	3033038	15	带垫螺栓	SCREW,CAPTIVE WASHER	18	
03	3055069		放油塞总成	PLUG,THREADED	1	
03	3073213	19	机油盘联接体盖衬垫	GASKET OIL PAN	1	
02	3000204	21	铜垫圈	WASHER, COPPER	2	
02	S 181 C	20	六角螺栓	SCREW,HEXAGON HEAD CAP	2	

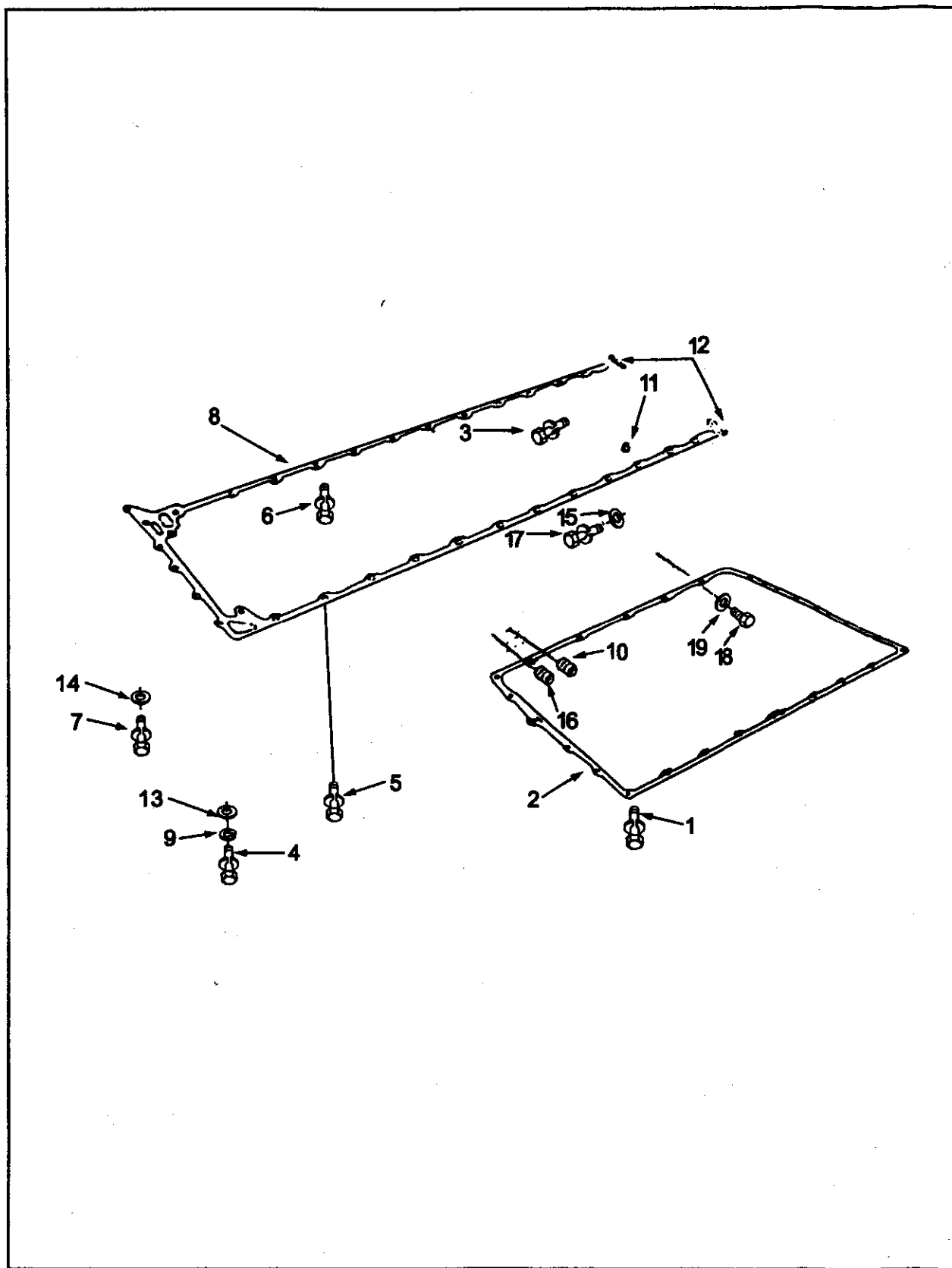

级 别	零 件 号	图 上 标 号	零 件 名 称		数 量	备 注
			中 文	英 文		
02	3016725		机油盘联接体安装	MTG,OIL PAN ADAPT	1	
03	127362	14	平垫圈	WASHER,PLAIN	2	
03	137980	4	六角螺栓	SCREW,HEXAGON HEAD CAP	1	
03	153518	11	矩型密封圈	SEAL,RECTANGULAR	4	
03	3012475	7	带垫螺栓	SCREW,CAPTIVE WAS	1	
03	3012478	5	带垫螺栓	SCREW,CAPTIVE WASHER	2	
03	3012481	17	六角螺栓	SCREW,HEXAGON HEAD	2	
03	3013786	16	管塞	PLUG,PIPE	1	
03	3025460	10	管塞	PLUG,PIPE	1	
03	3033038	6	带垫螺栓	SCREW,CAPTIVE WASHER	28	
03	3035624	3	带垫螺栓	SCREW,CAPTIVE WASHER	5	
03	3046202		螺塞	PLUG,THREADED	2	
04	3040810	18	螺塞	PLUG,THREADED	1	
04	3046201	19	O型圈	SEAL,O RING	1	
03	3069844	12	矩型带	SEAL,RECTANGULAR STRIP	2	
03	4000595	8	机油盘连接体衬垫	GASKET,OIL PAN	1	
03	S 609	9	弹簧垫圈	WASHER,LOCK	1	
03	S 622	15	平垫圈	WASHER,PLAIN	2	
03	S 689	13	平垫圈	WASHER,PLAIN	1	
02	MP 5012		机油盘安装总成	PAN,OIL MTG	1	
03	127362		平垫圈	WASHER,PLAIN	28	
03	3033038	1	带垫螺栓	SCREW,CAPTIVE WASHER	28	
03	3042590	2	机油盘衬垫	GASKET,OIL PAN	1	

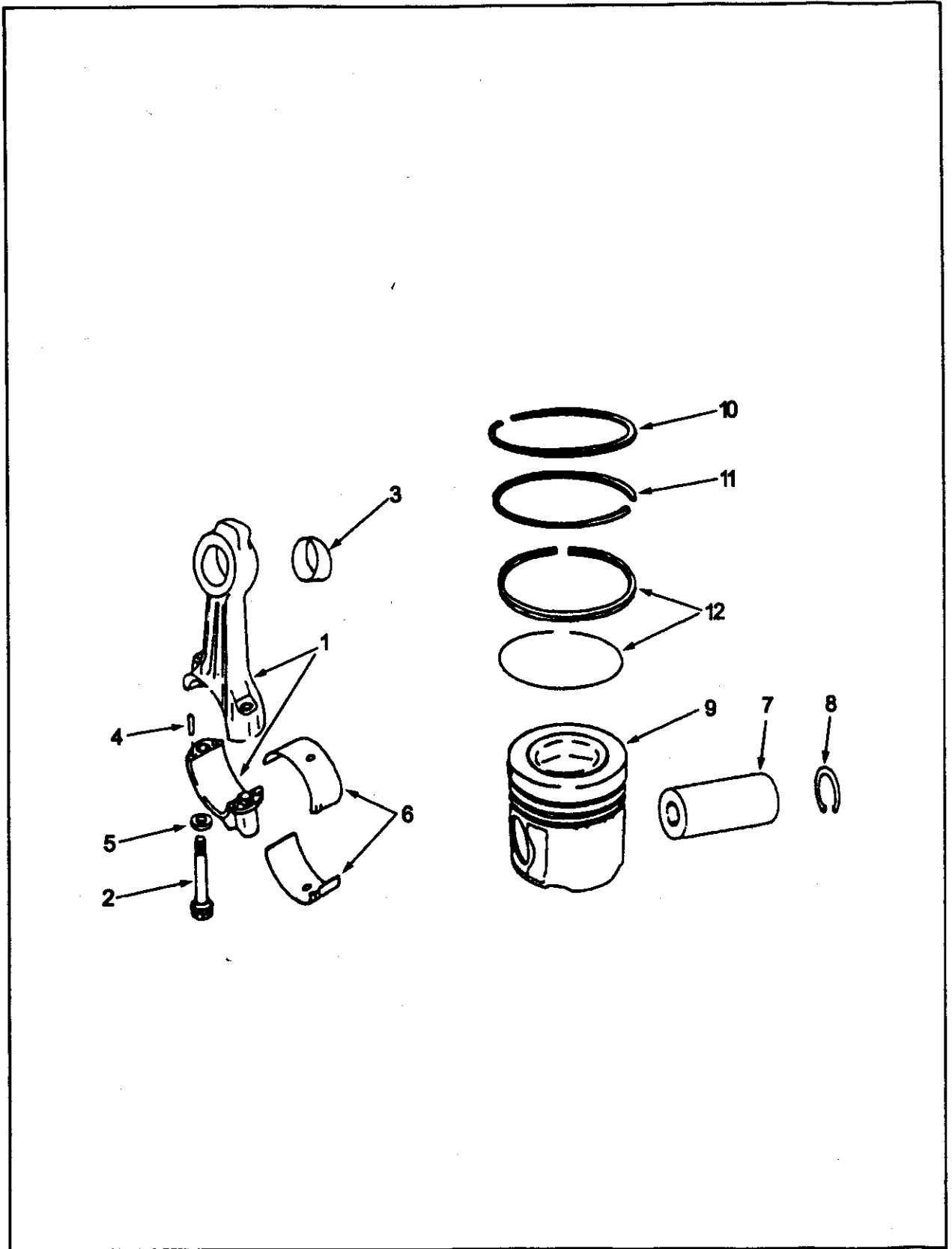

活塞和连杆

级别	零件号	图上 标号	零件名称		数量	备注
			中文	英文		
02	3039218		活塞连杆总成	PISTON & CONN ROD	6	
03	205200	7	活塞销	PIN,PISTON	1	
03	205269	8	挡圈	RING,RETAININGT	2	
03	205840	6	连杆瓦	BEARINGT,CONNECTING ROD	2	
03	3036073	12	活塞	PISTON,ENGINE	1	
03	3070589	10	压缩环	RING,COMPRESSION PISTON	1	
03	3090450	12	油环	RING OIL PISTON	1	
03	3090460	11	压缩环	RING COMPRESSION PISTON	1	
03	3811995		发动机连杆	ROD,ENGINE CONNECTING	1	
04	69558	4	定位销	DOWEL,PIN	4	
04	205126	5	平垫圈	WASHER,PLAIN	2	
04	3013265	2	连杆螺栓	SCREW,CONNECTING ROD CAP	2	
04	3043909	3	衬套	BUSHING	1	
04	3811994	1	连杆	ROP,ENGIN CONNEC	1	
03	205841	6	连杆瓦	BEARINGT,CONNECTING ROD	2	加厚0.01INCH
03	205842	6	连杆瓦	BEARINGT,CONNECTING ROD	2	加厚0.02INCH
03	205843	6	连杆瓦	BEARINGT,CONNECTING ROD	2	加厚0.03INCH

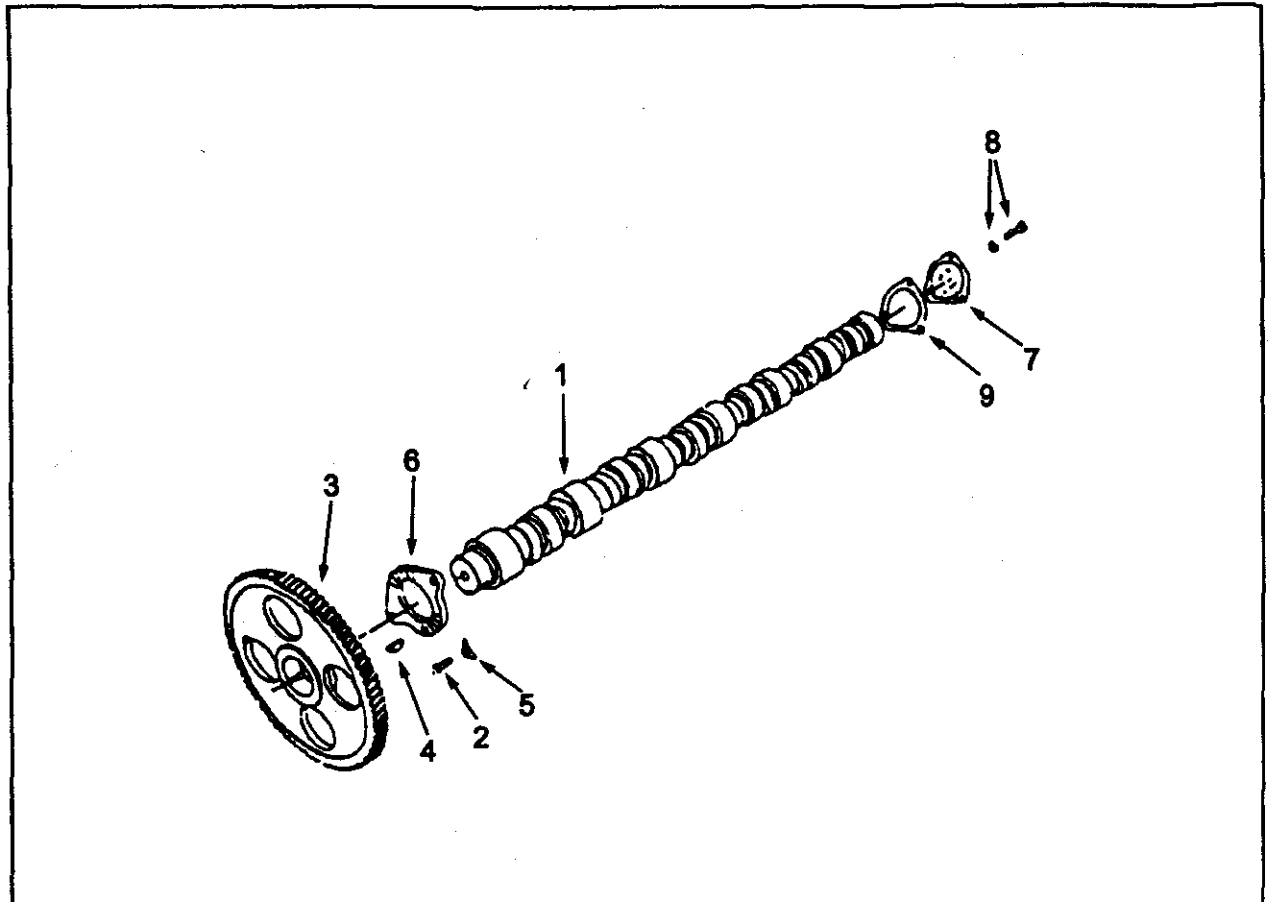

级别	零件号	图上 标号	零件名称		数量	备注
			中文	英文		
02	3028959		凸轮轴	CAMSHAFT	1	适用于G3
03	200708	4	半圆键	KEY,OFFSET WOODRUFF	1	
03	207248	3	凸轮轴齿轮	GEAR,CAMSHAFT	1	
03	207770	1	凸轮轴	CAMSHAFT	1	
03	3007971	6	凸轮轴止推轴承	BEARING,CAMSHAFT THRUST	1	
02	MP 4970		凸轮轴安装	CAMSHAFT, MTG	1	
03	68908	5	螺栓锁紧片	LOCK PLANE CAPSCREW	2	
03	S 112	2	螺栓	SCREW,HEXAGON HEAD CAP	2	
02	207373	7	凸轮轴端盖	COVER,CAMSHAFT	1	
02	MP 4981		凸轮轴盖安装	WASHER,LOCK	1	
03	3014766	8	带垫螺栓	SCREW,CAPTIVE WASHER CAP	3	
03	3040722	9	凸轮轴盖衬垫	GASKET,CAMSHAFT COVER	1	

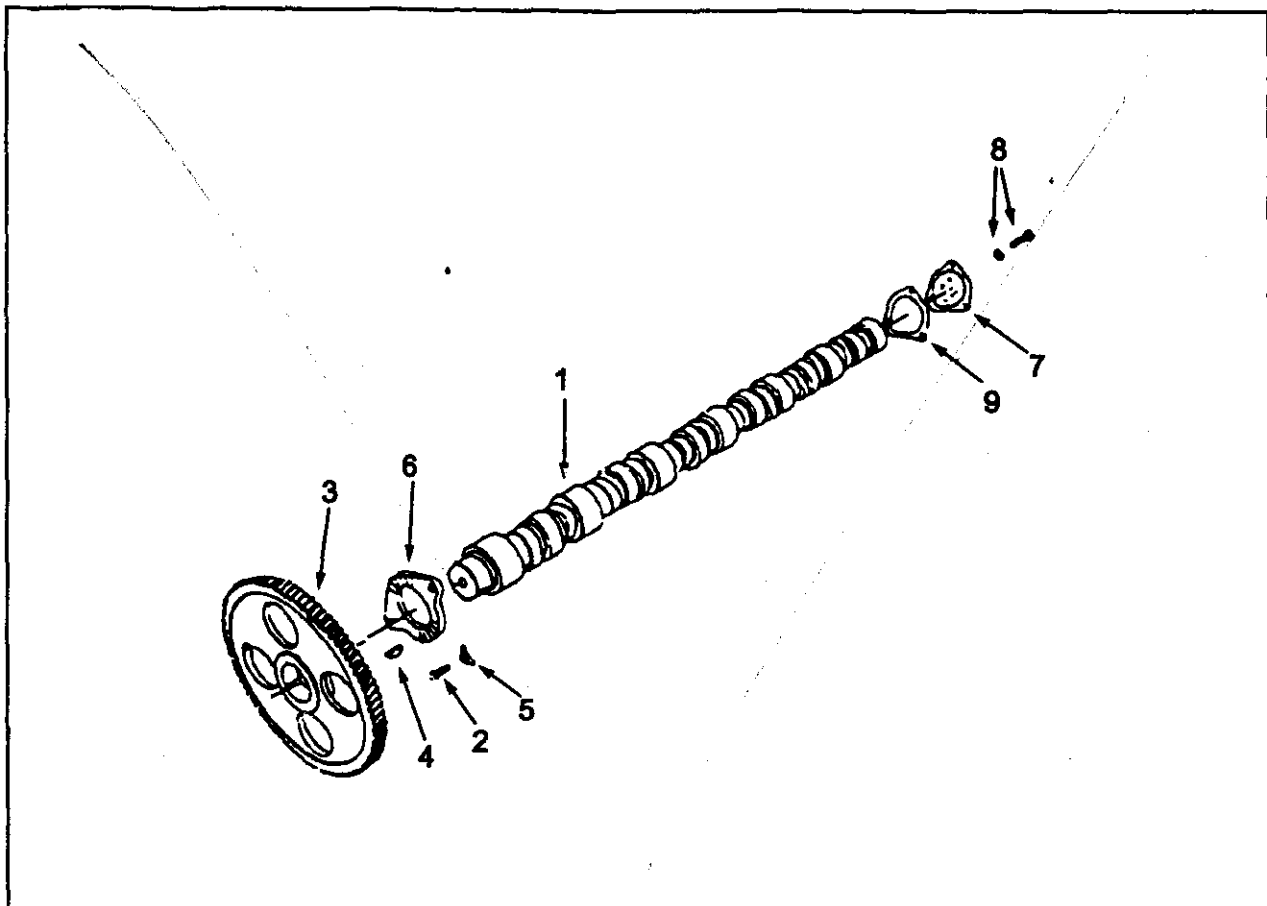

级别	零件号	图上 标号	零件名称		数量	备注
			中文	英文		
02	3028959		凸轮轴	CAMSHAFT	1	适用于G4
03	200708	4	半圆键	KEY,OFFSET WOODRUFF	1	
03	207248	3	凸轮轴齿轮	GEAR,CAMSHAFT	1	
03	207770	1	凸轮轴	CAMSHAFT	1	
03	3007971	6	凸轮轴止推轴承	BEARING,CAMSHAFT THRUST	1	
02	MP 4970		凸轮轴安装	CAMSHAFT, MTG	1	
03	68908	5	螺栓锁紧片	LOCK PLANE CAPSCREW	2	
03	S 112	2	螺栓	SCREW,HEXAGON HEAD CAP	2	
02	207373	7	凸轮轴端盖	COVER,CAMSHAFT	1	
02	MP 4981		凸轮轴盖安装	WASHER,LOCK	1	
03	3014766	8	带垫螺栓	SCREW,CAPTIVE WASHER CAP	3	
03	3040722	9	凸轮轴盖衬垫	GASKET,CAMSHAFT COVER	1	

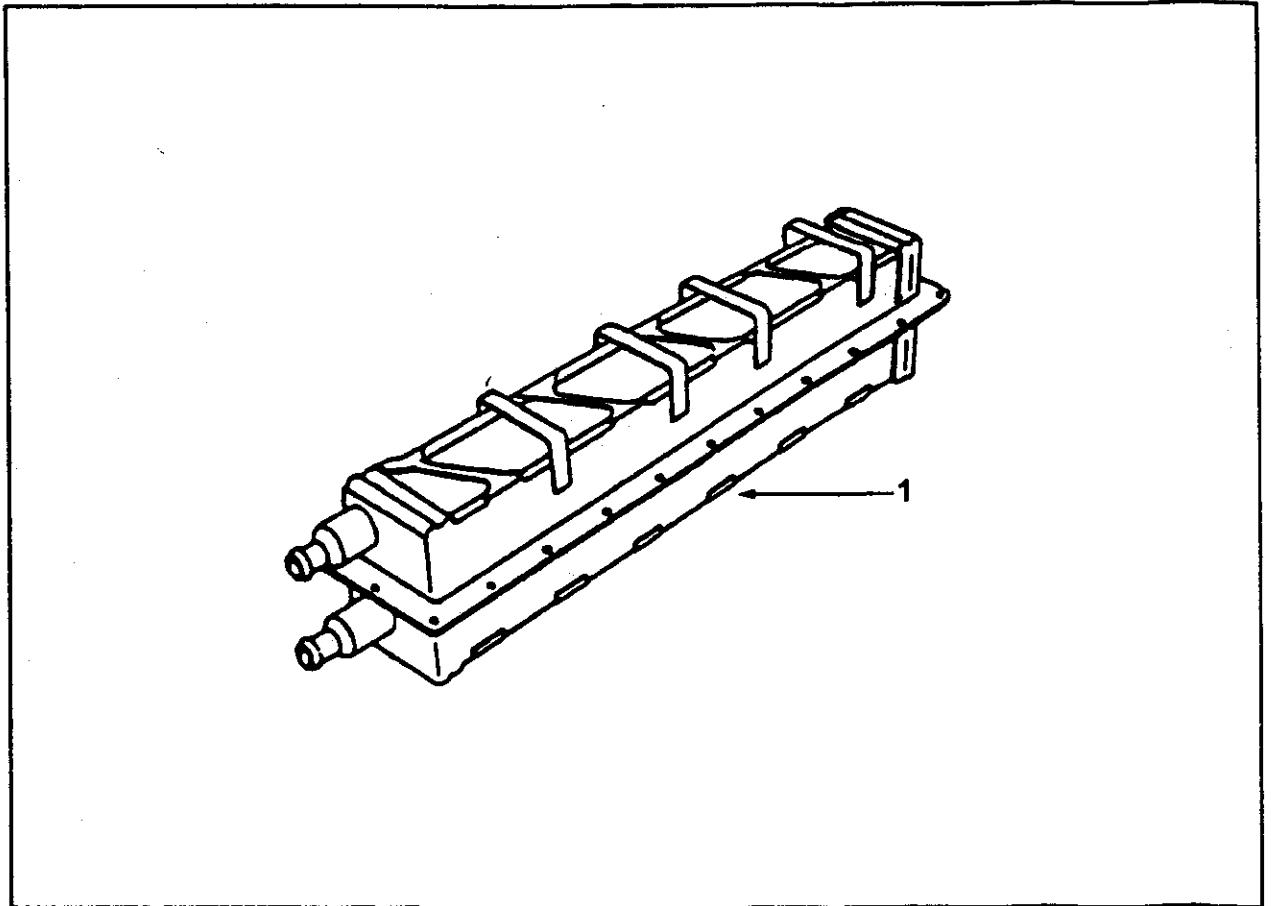

级别	零件号	图上 标号	零件名称		数量	备注
			中文	英文		
02	3001299	1	中冷器芯	CORE,AFTER COOLER	1	

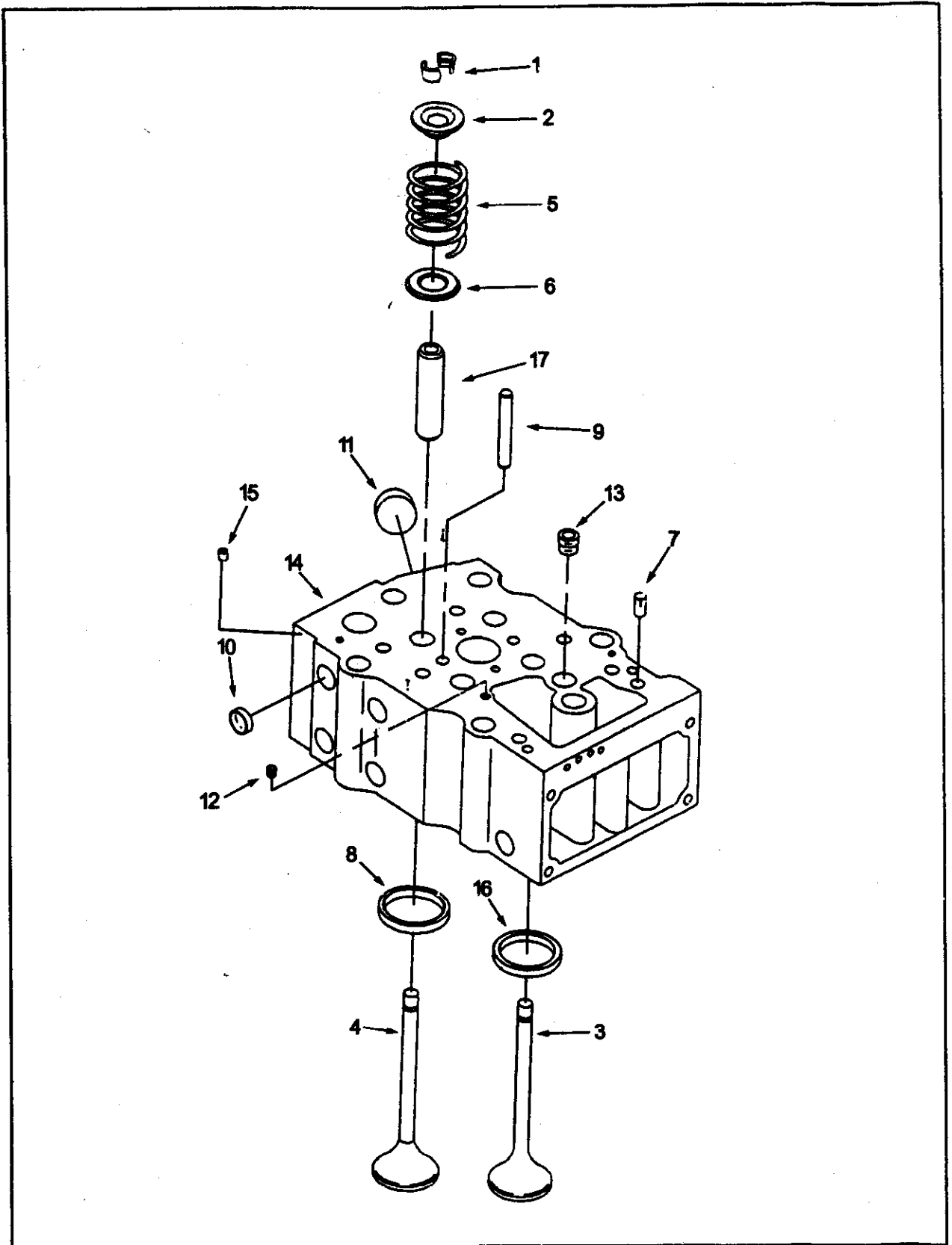

气 缸 盖

级 别	零 件 号	图 上 标 号	零 件 名 称		数 量	备 注
			中 文	英 文		
02	3811985		气缸盖	HEAD,CYLINDER	6	
03	205091	1	气门锁夹	COLLET,VALVE	8	
03	205094	2	气门弹簧上座	RETAINER,VALVE SPRING	4	
03	3052820	3	进气门	VALVE,INTAKE	2	
03	3081081	6	气门转子	ROTATER	4	
03	3088389	4	排气门	VALVE,EXHAUST	2	
03	3633840	5	气门弹簧	SPRING,VALVE	4	
03	3811981		气缸盖	HEAD,CYLINDER	1	
04	68445	7	带槽圆柱销	PIN,GROOVE	2	
04	3081065		气缸盖	HEAD,CYLINDER	1	
05	67622	12	管塞	PLUG,PIPE	1	
05	203933	15	碗型塞	PLUG,EXPANSION	1	
05	205093	8	排气门镶座	INSERT,VALVE	2	
05	205401	10	碗型塞	PLUG,EXPANSION	8	
05	206224	11	碗型塞	PLUG,EXPANSION	2	
05	3052819	16	气门座圈	INSERT,VALVE	2	
05	3081064	14	气缸盖	HEAD,CYLINDER	1	
05	3202210	17	气门导管	GUIDE,VALVE STEM	4	
05	S 915	13	管塞	PLUG,PIPE	1	

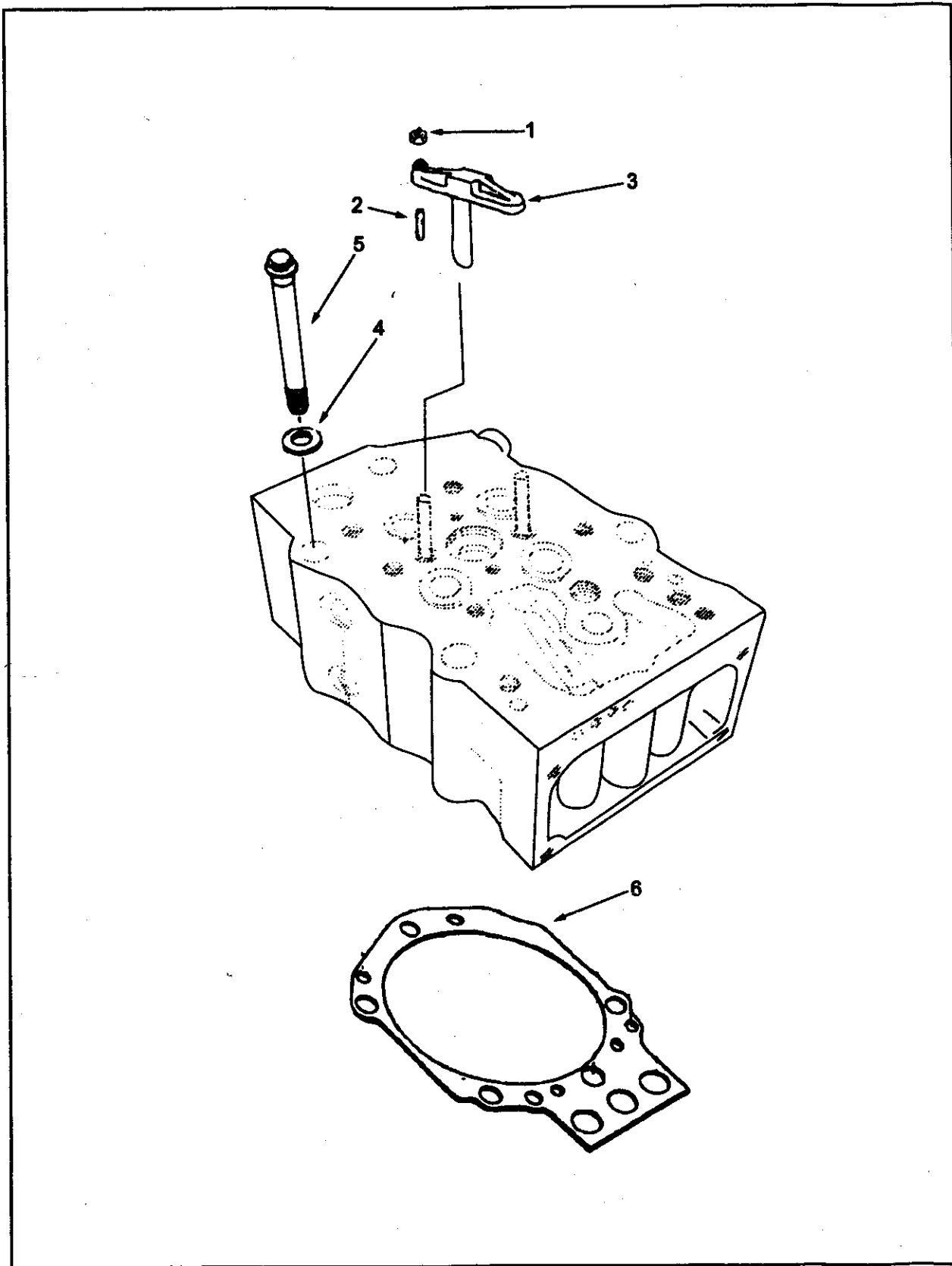

气 缸 盖 安 装

级 别	零 件 号	图 上 标 号	零 件 名 称		数 量	备 注
			中 文	英 文		
02	3013962		气 缸 盖 安 装	HEAD,CYLINDER MTG	6	
03	205059	4	平 垫 圈	WASHER,PLAIN	6	
03	3032633	5	十 二 角 螺 栓	SCREW,TWELVE POINT CAP	6	
03	3086362	3	丁 字 压 板	CROSSHEAD,VALVE	2	
02	3166289	6	汽 缸 垫	GASKET,CYLINDER H	6	

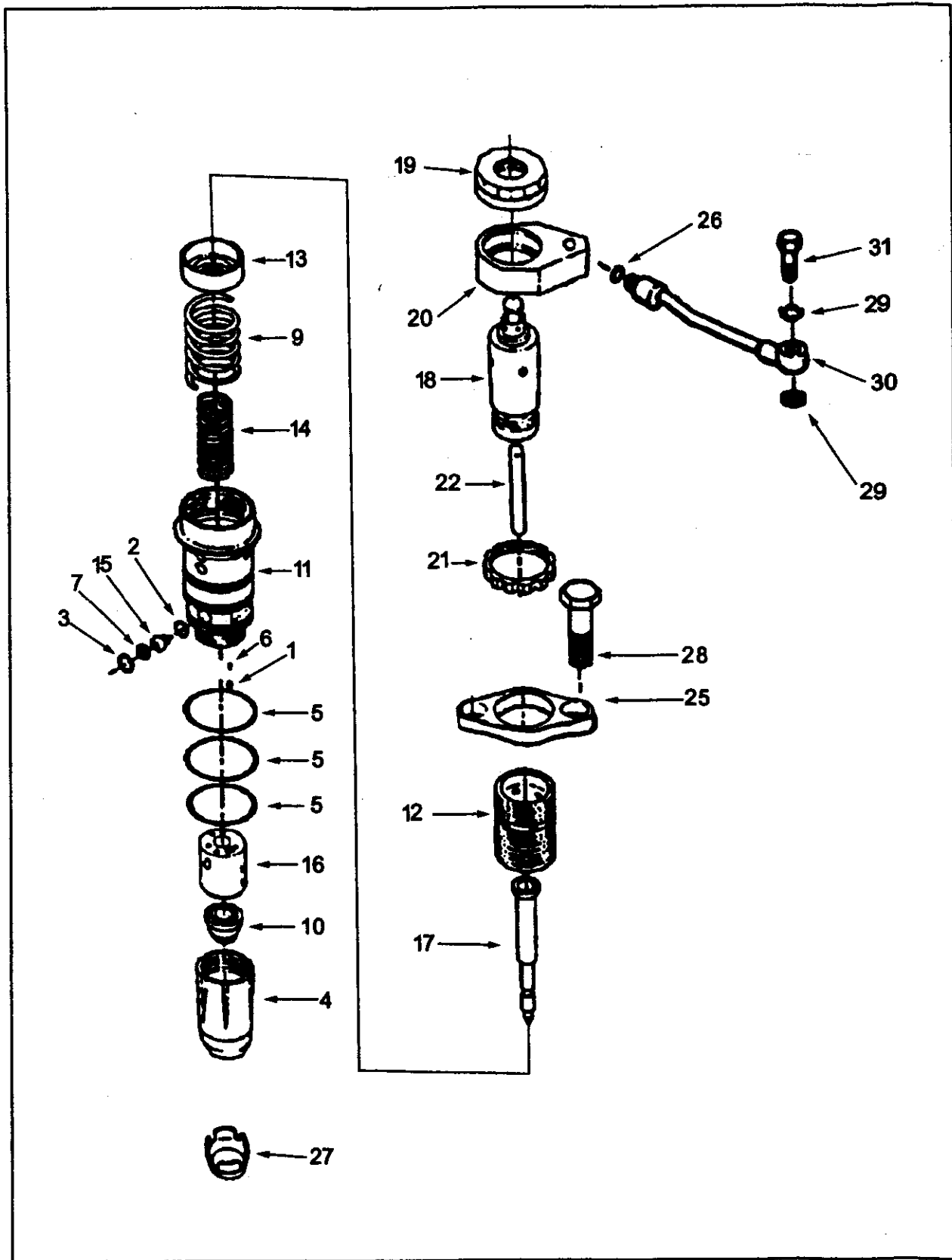

级别	零件号	图上 标号	零件名称		数量	备注
			中文	英文		
02	3077715		喷油器	INJECTOR	6	总成装配
	167157	1	止回球阀	BALL,CHECK	1	
	173086	2	衬垫	GASKET,INJECTOR	1	
	174299	3	挡板	RETAINER,SCREEN	1	
	193736	5	O型密封圈	SEAL,O RING	3	
	203426	6	圆柱销	PIN,ROLL	2	
	3042425	11	喷油器体	ADAPTER,INJECTOR	1	
	3042427	14	喷油器弹簧	SPRING, INJECTOR	1	
	3042428	9	喷油器弹簧	SPRING, INJECTOR	1	
	3042430	4	螺帽	RETAINER,INJECTOR CUP	1	
	3045047	15	堵塞	PLUG,INJECTOR ORIFICE	1	
	3052218	13	弹簧螺帽	RETAINER,INJECTOR SPR	1	
	3054999	7	过滤板	SCREEN,FILTER	1	
	3068859	19	喷油器顶帽	CAP,TAPPET TOP STOP	1	
	3068860	21	锁紧螺母	NUT,LOCK	1	
	3075381	18	HVT挺杆	TAPPET,HYD VAR TIMING	1	
	3076125		柱塞副总成	BARREL & PLUNGER	1	
	(3053502)	16	柱塞套	BARREL,INJECTOR	1	
	(3076124)	17	柱塞	PLUNGER,INJECTOR	1	
	3077716	10	喷油器帽	CUP,INJECTOR	1	
	3279819	22	喷油器连接杆	LINK,INJECTOR PLUNGER	1	
	3279821	12	螺栓	SCREW,INJECTOR STOP	1	
	3279850	20	锁紧螺母	NUT,TAPPET TOP STOP LOC	1	
	3411695	25	喷油器压板	CLAMP,INJECTOR	1	
02	3073205		喷油嘴安装	INJECTOR MTG.	6	
03	131026	26	O型密封圈	SEAL,O RING	1	
03	207244	27	喷油器密封环	SEAL,INJECTOR	1	
03	3023095	29	垫圈	WASHER,SEALING	2	
03	3070962	28	六角螺栓	SCREW,HEXAGON HEAD CAP	2	
03	3179021	31	螺栓	SCREW,BANJO CONNECTOR	1	
03	3627044	30	HVT机油输油管	CONNECTION,OIL TRANSFER	1	

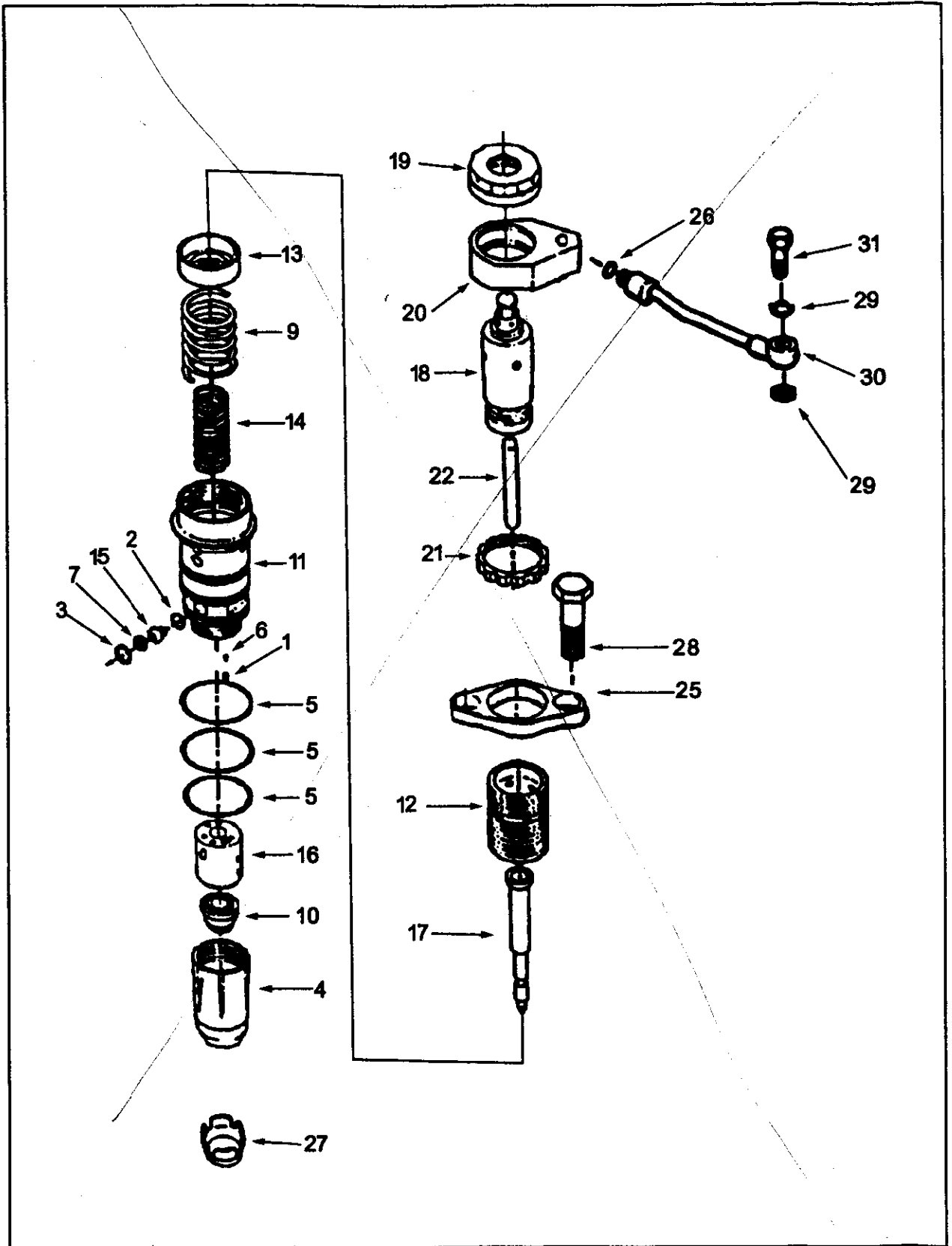

级别	零件号	图上 标号	零件名称		数量	备注
			中文	英文		
02	3095773		喷油器	INJECTOR	6	总成装配
	167157	1	止回球阀	BALL,CHECK	1	
	173086	2	衬垫	GASKET,INJECTOR	1	
	174299	3	挡板	RETAINER,SCREEN	1	
	193736	5	O型密封圈	SEAL,O RING	3	
	203426	6	圆柱销	PIN,ROLL	2	
	3042425	11	喷油器体	ADAPTER,INJECTOR	1	
	3042427	14	喷油器弹簧	SPRING, INJECTOR	1	
	3042428	9	喷油器弹簧	SPRING, INJECTOR	1	
	3042430	4	螺帽	RETAINER,INJECTOR CUP	1	
	3045047	15	堵塞	PLUG,INJECTOR ORIFICE	1	
	3052218	13	弹簧螺帽	RETAINER,INJECTOR SPR	1	
	3054999	7	过滤板	SCREEN,FILTER	1	
	3068859	19	喷油器顶帽	CAP,TAPPET TOP STOP	1	
	3075381	18	HVT挺杆	TAPPET,HYD VAR TIMING	1	
	3076126		柱塞副总成	BARREL & PLUNGER	1	
	(3053504)	16	柱塞套	BARREL,INJECTOR	1	
	(3076124)	17	柱塞	PLUNGER,INJECTOR	1	
	3279720	10	喷油器帽	CUP,INJECTOR	1	
	3279821	12	螺栓	SCREW,INJECTOR STOP	1	
	3279850	20	锁紧螺母	NUT,TAPPET TOP STOP LOC	1	
	3411695	25	喷油器压板	CLAMP,INJECTOR	1	
	3627894	22	喷油器连接杆	LINK,INJECTOR PLUNGER	1	
02	3073205		喷油嘴安装	INJECTOR MTG.	6	
03	131026	26	O型密封圈	SEAL,O RING	1	
03	207244	27	喷油器密封环	SEAL,INJECTOR	1	
03	3023095	29	垫圈	WASHER,SEALING	2	
03	3070962	28	六角螺栓	SCREW,HEXAGON HEAD CAP	2	
03	3179021	31	螺栓	SCREW,BANJO CONNECTOR	1	
03	3627044	30	HVT机油输油管	CONNECTION,OIL TRANSFER	1	

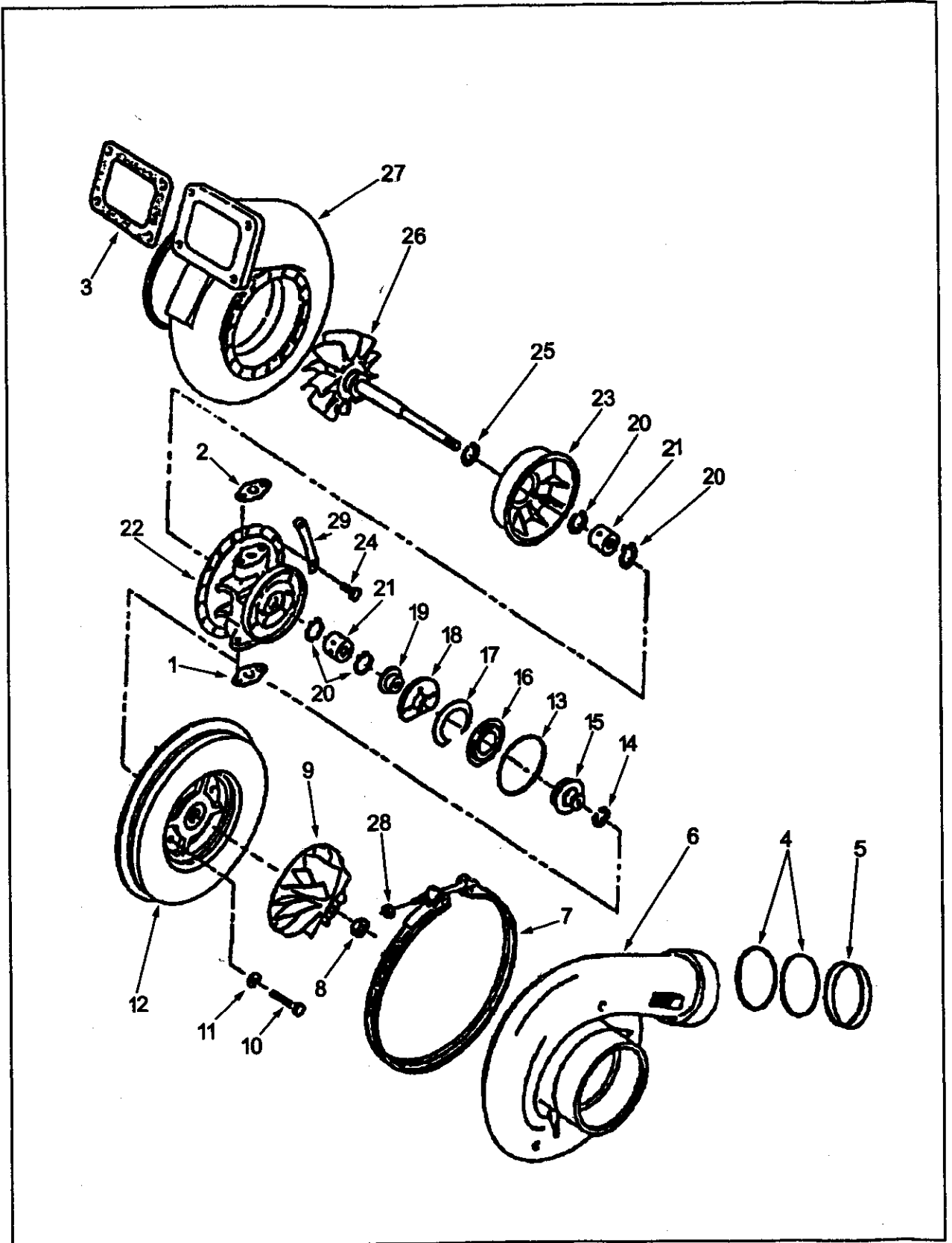

级别	零件号	图上 标号	零件名称		数量	备注	
			中文	英文			
02	3594118		增压器	TURBOCHARGER	1	总成装配	
	3502449	13	矩形密封圈	SEAL,RECTANGULAR RING	1		
	3504967	11	平垫圈	WASHER,PLAIN	4		
	3519535	8	锁紧螺母	NUT,LOCK	1		
	3519623	19	止推环	COLLAR,THRUST	1		
	3519627	21	轴承	BEARING,TURBOCHARGER	2		
	3519641	20	挡圈	RING,RETAINING	4		
	3519783	23	隔热板	SHIELD,TURBOCHARGER	1		
	3521033	26	轴和涡轮	SHAFT & WHEEL	1		
	3521225	24	六角螺栓	SCREW,HEXAGON HEAD SET	8		
	3521442	25	密封环	SEAL,SPLIT RING	1		
	3522631	7	V型带卡箍	GLAMP,V BAND	1		
	3522904	29	锁片	LOCKPLATE	4		
	3523412	14	密封环	SEAL,SPLIT RING	1		
	3523429	22	轴承壳	HOUSING,TUR BEARING	1		
	3523980	15	抛油环	SLINGER,OIL	1		
	3524418	17	调整垫片	SHIM	1		
	3524419	16	挡油板	BAFFLE,HEXAGON HEAD SET	1		
	3525073	10	六角螺栓	SCREW,HEXAGON HEAD SET	4		
	3526985	18	止推轴承	BEARING,TUR THRUST	1		
	3527348	12	扩压板	DIFFUSER,TURBOCHARGER	1		
	3527369	6	压气机壳	HOUSING,COMPRESSOR	1		
	3529372	28	六角螺母	NUT,REGULAR HEXAGON	1		
	3533703	9	叶轮	IMPELLER,TUR COMPRESSOR	1		
	3534201	27	涡壳	HOUSING,TURBINE	1		
		201048	1	衬垫	GASKET,CONNECTION		1
		201049	2	衬垫	GASKET,CONNECTION		1
		206576	3	增压器衬垫	GASKET,TURBOCHAGER		1
		3023066	4	O型密封圈	SEAL,O RING		2
		3023129	5	尘封	SEAL,DUST		1

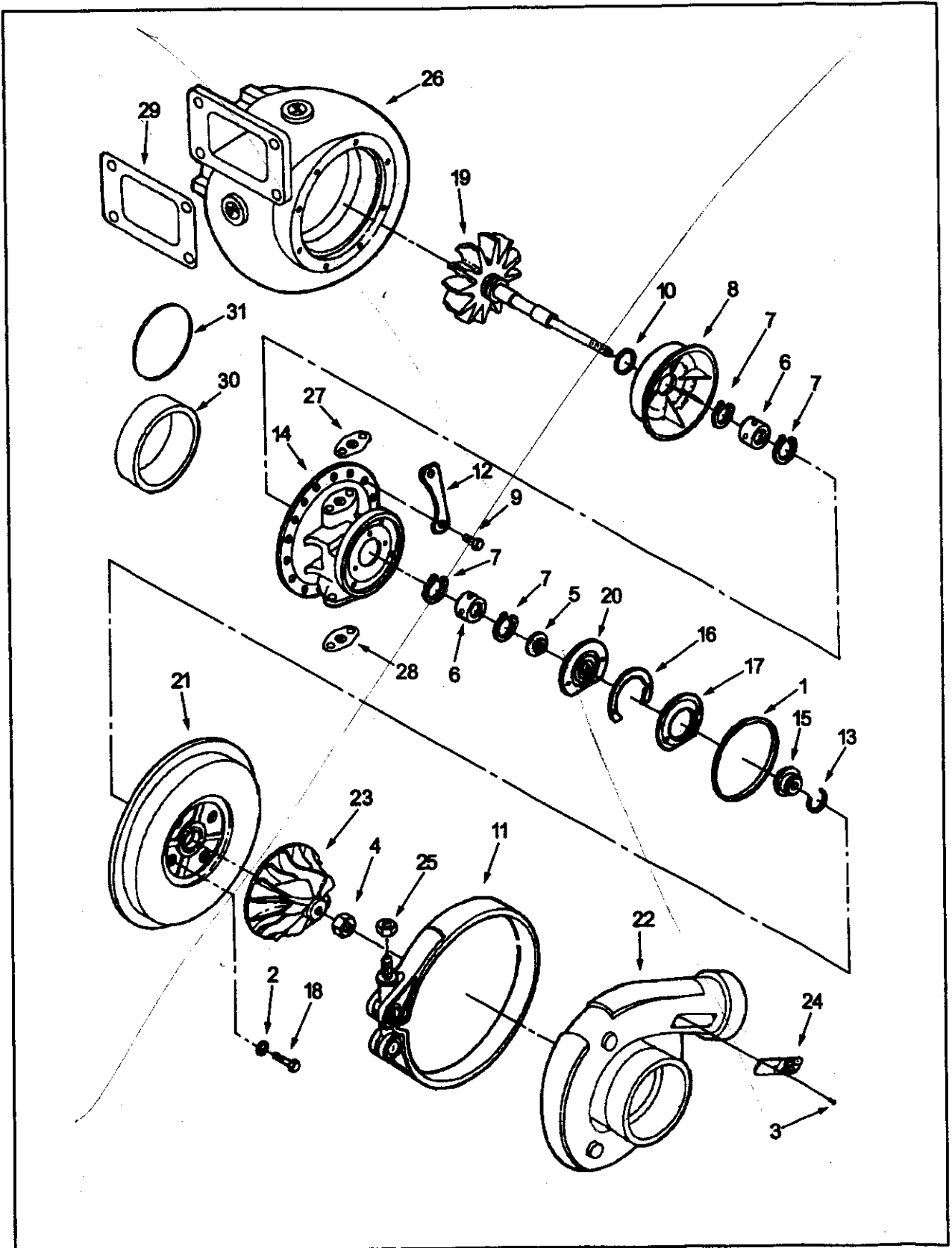

增压器 G4

级别	零件号	图上 标号	零件名称		数量	备注
			中文	英文		
02	3594134		增压器	TURBOCHARGER	1	总成装配
	3502449	1	矩形密封圈	SEAL,RECTANGULAR RING	1	
	3504967	2	平垫圈	WASHER,PLAIN	4	
	3519163	3	自攻螺栓	SCREW,DRIVE	2	
	3519535	4	锁紧螺母	NUT,LOCK	1	
	3519623	5	止推环	COLLAR,THRUST	1	
	3519627	6	轴承	BEARING,TURBOCHARGER	2	
	3519641	7	挡圈	RING,RETAINING	4	
	3519783	8	隔热板	SHIELD,TURBOCHARGER	1	
	3521225	9	六角螺栓	SCREW,HEXAGON HEAD SET	8	
	3521442	10	密封环	SEAL,SPLIT RING	1	
	3522631	11	V型带卡箍	GLAMP,V BAND	1	
	3522904	12	锁片	LOCKPLATE	4	
	3523412	13	密封环	SEAL,SPLIT RING	1	
	3523429	14	轴承壳	HOUSING,TUR BEARING	1	
	3523980	15	抛油环	SLINGER,OIL	1	
	3524418	16	调整垫片	SHIM	1	
	3524419	17	挡油板	BAFFLE,HEXAGON HEAD SET	1	
	3525073	18	六角螺栓	SCREW,HEXAGON HEAD SET	4	
	3521033	19	轴和涡轮	SHAFT & WHEEL	1	
	3526985	20	止推轴承	BEARING,TUR THRUST	1	
	3527348	21	扩压板	DIFFUSER,TURBOCHARGER	1	
	3527369	22	压气机壳	HOUSING,COMPRESSOR	1	
	3533703	23	叶轮	IMPELLER,TUR COMPRESSOR	1	
	3527619	24	铭牌	DATAPLATE	1	
	3529372	25	六角螺母	NUT,REGULAR HEXAGON	1	
	3524753	26	涡轮壳	HOUSING,TURBINE	1	
	201048	28	衬垫	GASKET,CONNECTION	1	
	201049	27	衬垫	GASKET,CONNECTION	1	
	206576	29	增压器衬垫	GASKET,TURBOCHAGER	1	
	3023066	31	O型密封圈	SEAL,O RING	2	
	3023129	30	尘封	SEAL,DUST	1	

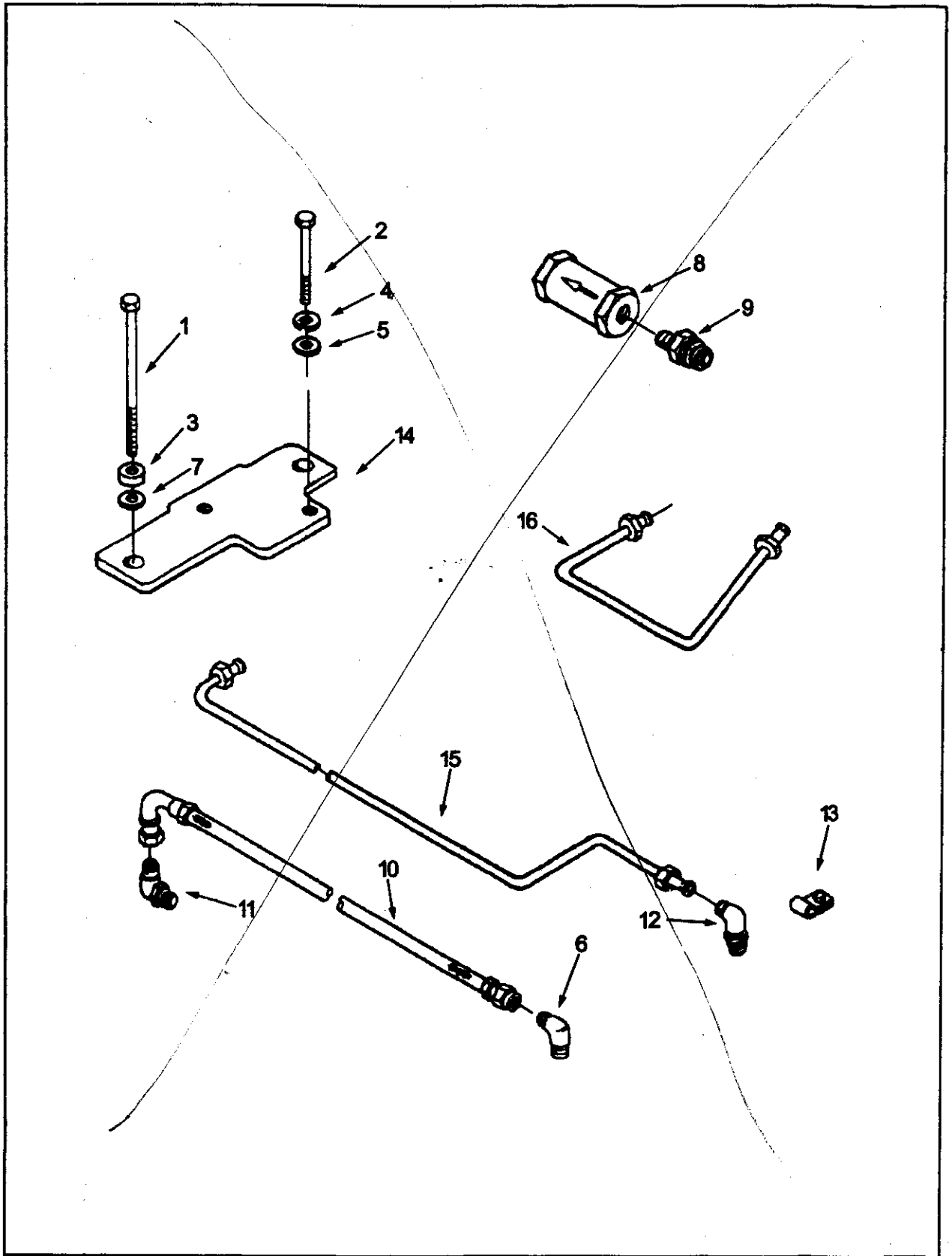

机油控制阀(STC) G4

级别	零件号	图上 标号	零件名称		数量	备注
			中文	英文		
02	3096082		STC及安装	HYDRO-MECHANICAL STC	1	G4
03	63385	3	隔套	SPACER, WATER CONN	2	
03	68645	6	阳性连接弯管	ELBOW, MALE ADAPTER	1	
03	118346	9	接头	UNION, MALE	1	
03	137868	1	六角螺栓	SCREW, HEXAGON HEAD CAP	2	
03	178079	8	单向阀	VALVE, CHECK	1	
03	180371	13	夹子	CLIP	2	
03	3035580	10	软管	HOSE, FLEXIBLE	2	
03	3037662	12	阳性弯接头	ELBOW, MALE UNION	1	
03	3070947	15	供油管	TUBE, FUEL SUPPLY	1	
03	3070949	16	回油管	TUBE, LUB OIL DRAIN	1	
03	3096081		机油控制阀	VALVE, OIL CONTROL	1	详见下页
03	3629505	11	异径三通接头	TEE, CONNECTOR	1	
03	S 185	A 2	六角螺栓	SCREW, HEXAGON HEAD CAP	2	
03	S 602	7	平垫圈	WASHER, PLAIN	2	
03	S 605	4	弹簧垫圈	WASHER, LOCK	2	
03	S 626	5	平垫圈	WASHER, PLAIN	2	
02	3077983		凸轮轴从动件盖安装	COVER, CAM FOLLOWER	1	
03	3040721		凸轮从动件衬垫	GASKET, CAM FOL HOUSING	1	
03	3040838		带垫螺栓	SCREW, CAPTIVE WASHER CAP	2	
03	3060567		带垫螺栓	SCREW, CAPTIVE WASHER CAP	2	
03	3088375	14	支架	BRACKET, VALVE	1	

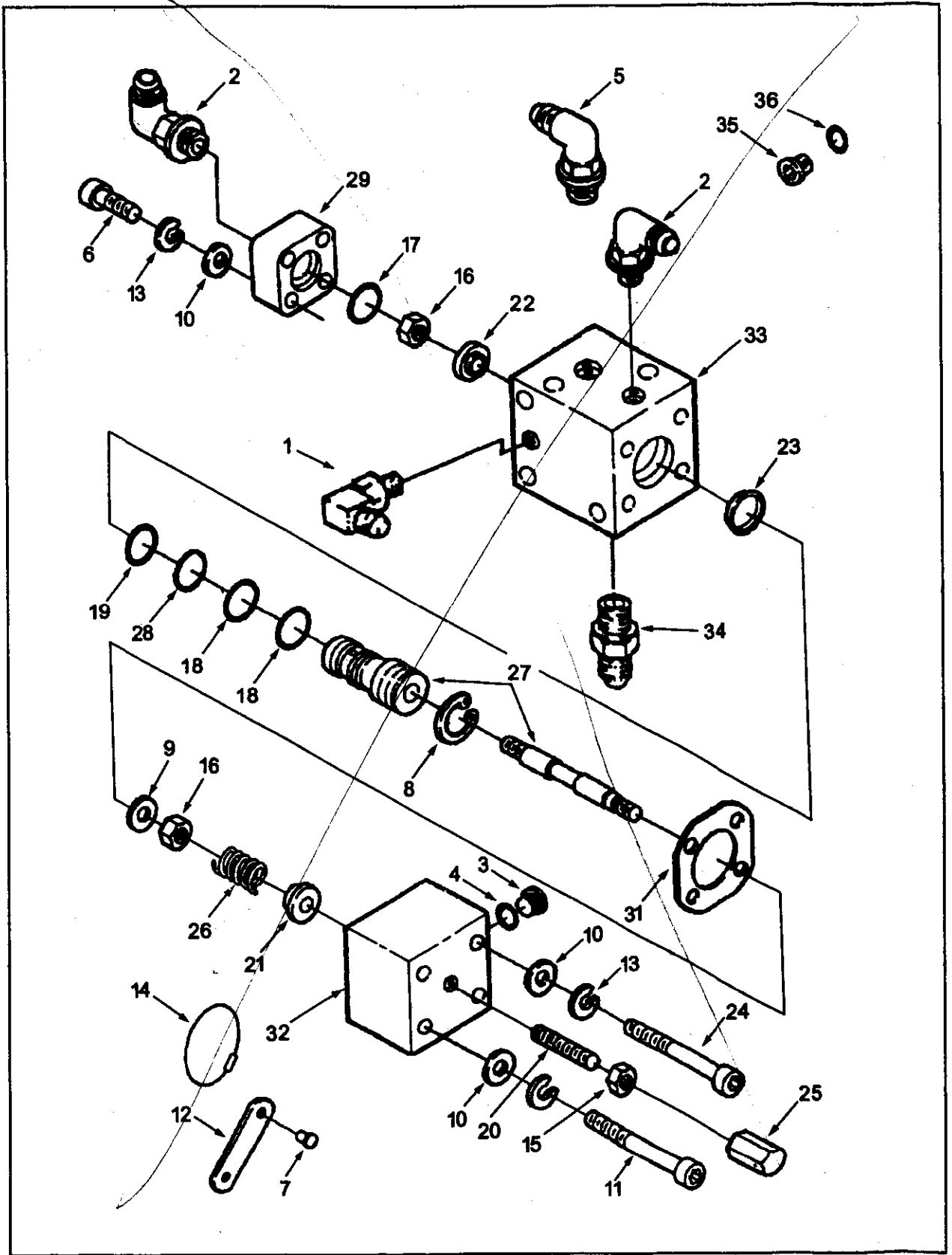

级别	零件号	图上 标号	零件名称		数量	备注
			中文	英文		
03	3096081		机油控制阀(STC阀)	VALVE,OIL CONTROL	1	总成装配
04	3017115	34	阳性接头	CONNECTOR,MALE	1	
04	3037535	5	阳性弯接头	ELBOW,MALE UNION	1	
04	3037662	2	阳性接头	ELBOW,MALE UNION	2	
04	3066811		机油控制阀	VALVE,OIL CONTROL	1	
05	S 2286	7	自攻螺钉	SCREW,DRIVE	2	
05	S 16240	8	挡圈	RING,RETAINING	1	
05	105375	12	铭牌	NAMEPLATE	1	
05	3033742		螺塞	PLUG,THREADED	1	
06	3034412	36	O形密封圈	SEAL,O RING	1	
06	3079584	35	螺塞	PLUG,THREADED	1	
05	3034408	17	O型密封圈	SEAL,O RING	1	
05	3040814		螺塞	PLUG,THREADED	1	
06	3036665	3	螺塞	PLUG,THREADED	1	
06	3036666	4	O型密封圈	SEAL,O RING	1	
05	3042542	18	O型密封圈	SEAL,O RING	2	
05	3045986	19	O型密封圈	SEAL,O RING	1	
05	3049041	21	弹簧护圈	RETAINER,SPRING	1	
05	3051069	26	压缩弹簧	SPRING,COMPRESSION	1	
05	3054411	23	弹簧片	SPRING,LEAF	1	
05	3060605	27	柱塞副	BARREL & PLUNGER	1	
05	3066914	28	O型密封圈	SEAL,O RING	1	
05	3069015	16	锁紧螺母	NUT,LOCK	1	
05	3069989	29	机油控制阀盖	COVER,OIL CONTROL VALVE	1	
05	3070108	31	机油控制阀体衬垫	GASKET,CONTROL VALVE BO	1	
05	3070167	33	机油控制阀体	BODY,OIL CONTROL VALVE	1	
05	3070186	9	平垫圈	WASHER,PLAIN	1	
05	3073998	22	阀门片	DISC,VALVE	1	
05	3417077	6	内六角螺栓	SCREW,SOCKET HEAD CAP	4	
05	3417096	20	摇臂轴固定螺钉	SCREW,SOCKET SET	1	
05	3417098	11	内六角螺栓	SCREW,SOCKET HEAD CAP	4	
05	4009927	32	隔板盖	COVER,DIAPHRAGM	1	

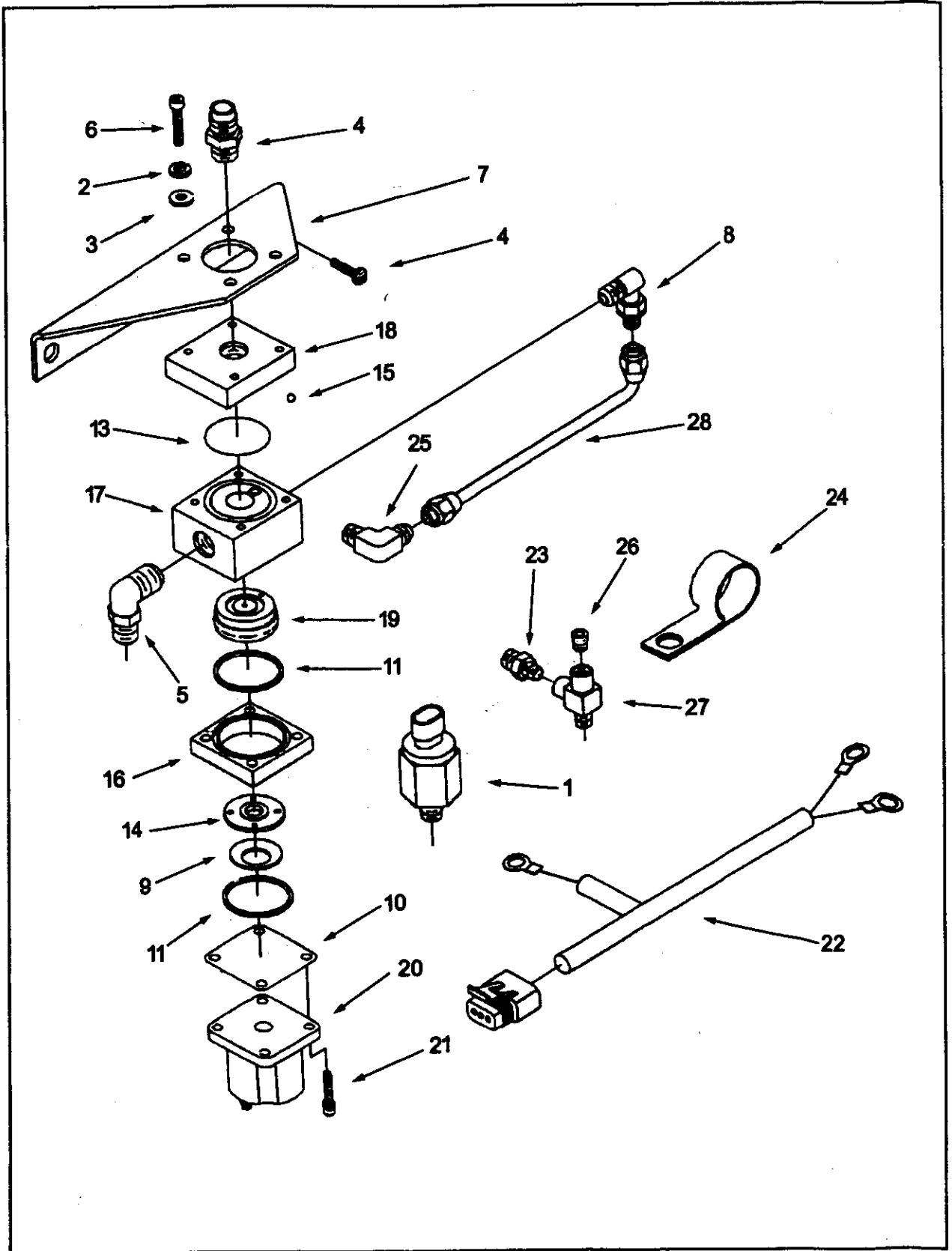

级别	零件号	图上 标号	零件名称		数量	备注
			中文	英文		
02	3054615	1	压力开关	SWITCH,PRESSURE	1	G3
02	3065825		HVT 单向阀管路	TUBING,HVT CHECK VALVE	1	
03	S 607	2	弹簧垫圈	WASHER,LOCK	4	
03	70620	3	平垫圈	WASHER,PLAIN	4	
03	118346	4	接头	UNION,MALE	1	
03	118347	5	阳性接头	ELBOW,MALE UNION	1	
03	180372		夹子	CLIP	4	
03	192861	6	内六角螺栓	SCREW,SOCKET HEAD CAP	4	
03	3035738		切断阀	VALVE,SHUTOFF	1	
	129768	9	切断阀弹簧	SPRING,VALVE	1	
	129839	10	切断阀护板	SHIELD,SHUTOFF VALVE	1	
	129888	11	矩形圈	SEAL,RECTANGULAR RING	2	
	138764	12	连接螺栓	SCREW,PAN HEAD CAP	2	
	145536	13	O型密封圈	SEAL,O RING	1	
	196057	14	阀门片	DISC,VALVE	1	
	3015521	15	止回球阀	BALL	1	
	3034451	16	切断阀壳	HOUSING,ACTUATOR	1	
	3035739	17	切断阀体	BODY,SHUTOFF VALVE	1	
	3035740	18	切断阀盖	COVER,SHUTOFF VALVE	1	
	3041466	19	切断阀盘	DISC,ACTUATOR	1	
	3054609	20	电磁阀	SOLENOID	1	
	3065944	21	带垫螺栓	SCREW,CAPTIVE WASHER CA	4	
03	3037658	7	切断阀支架	BRACKET,SHUTOFF VALVE	1	
03	3038743	8	单向阀	VALVE,CHECK	1	
02	3067880	22	导线	HARNESS,WIRING	1	
02	3201953		压力开关安装	MTG,RAIL PRESSURE SWITCH	1	
03	68138	23	阳性管接头	CONNECTOR,MALE	1	
03	68143	24	夹子	CLIP	1	
03	112105	25	阳性弯接头	ELBOW,MALE ADAPTER	1	
03	3025460	26	管塞	PLUG,PIPE	1	
03	3202220	②8	压力信号管	TUBE,PRESSURE SENSING	1	
03	3629505	27	异径三通接头	TEE,CONNECTOR	1	

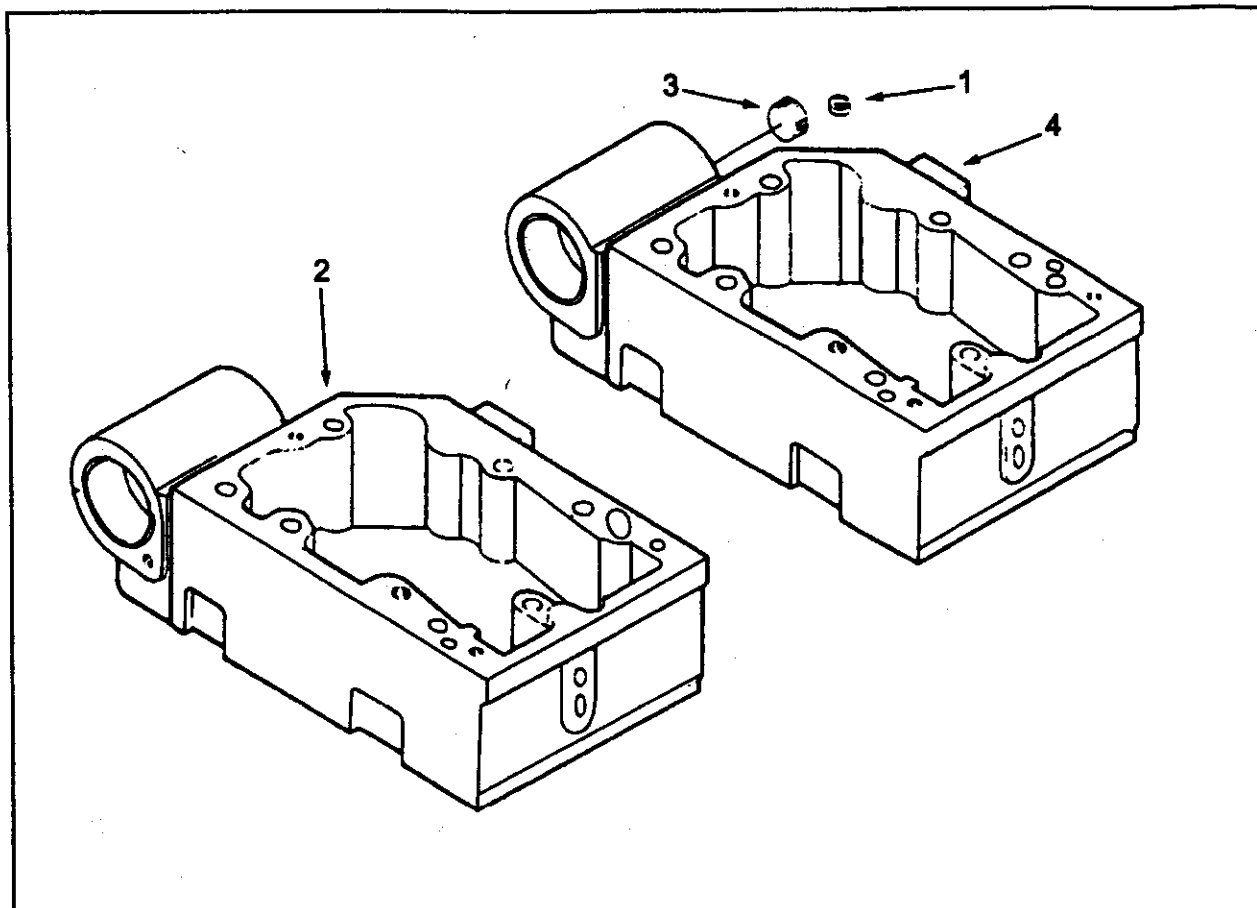

级别	零件号	图上 标号	零件名称		数量	备注
			中文	英文		
02	3039097		摇臂室	ASSY,ROCKER LEVER HOUSIN	5	
03	205129	1	摇臂轴定位环	DOWEL, RING	1	
03	3177713	2	摇臂室	HOUSING,ROCKER LEVER	1	
02	3047708		摇臂室	HOUSING,ROCKER	1	
03	3008469	3	管塞	PLUG,PIPE	1	
03	3039100		摇臂室	ASSY,ROCKER LEVER HOUSIN	1	
04	205129	1	摇臂轴定位环	DOWEL, RING	1	
04	3202198	4	摇臂室	HOUSING,ROCKER LEVER	1	

起动马达

ST 8048

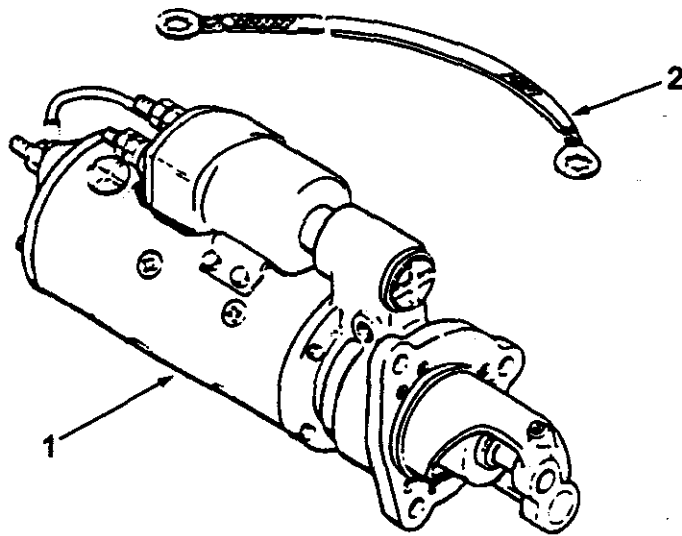

级别	零件号	图上 标号	零件名称		数量	备注
			中文	英文		
02	3043578		起动马达	MOTOR STARTING	1	
03	3018924	2	接地线	WIRE,GROUND	1	
03	3021038	1	起动马达	MOTOR,STARTNG	1	

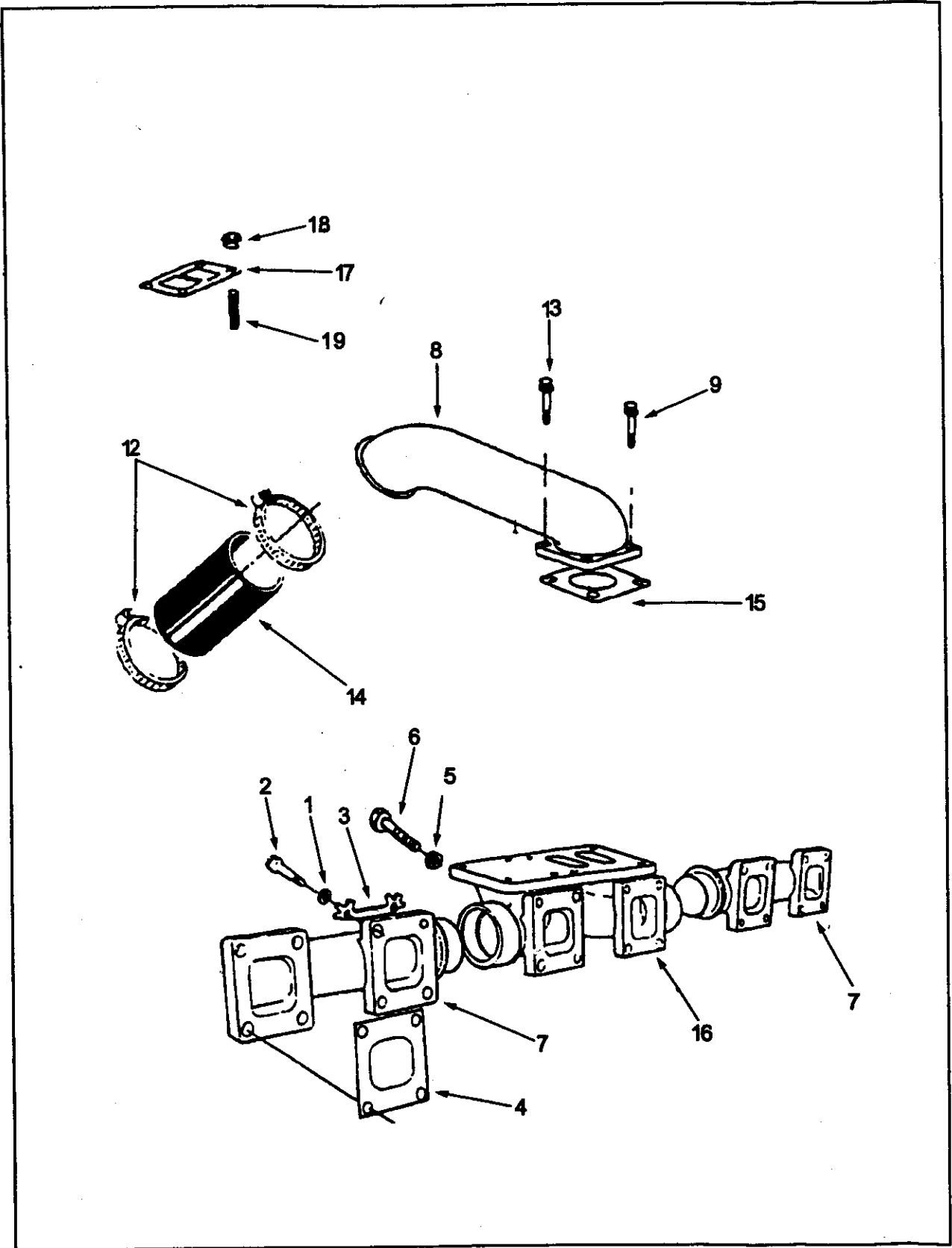

级 别	零 件 号	图 上 标 号	零 件 名 称		数 量	备 注
			中 文	英 文		
02	3037824	7	排气歧管	MANIFLOD,EXHAUST	2	
02	3166256		排气歧管	MANIFLOD,EXHAUST	1	
03	3042353	19	双头螺栓	STUD	4	
03	3080980	16	排气歧管	MANIFLOD,EXHAUST	1	
02	3088319		排气歧管安装	MANIFOLD,EXHAUST	2	
03	3043097	4	衬垫	GASKET,EXHAUST MANIFOLD	2	
03	3046283	2	六角螺栓	SCREW,HEX FLANGE HEAD CA	8	
03	3046286	1	安装隔套	SPACER,MOUNTING	8	
03	3088317	3	锁紧片	LOCKPLATE	4	
02	3088318		排气歧管安装	MANIFOLD,EXHAUST	1	
03	3035310	5	平垫圈	WASHER,PLAIN	4	
03	3043097	4	衬垫	GASKET,EXHAUST MANIFOLD	2	
03	3046283	2	六角螺栓	SCREW,HEX FLANGE HEAD CA	4	
03	3046286	1	安装隔套	SPACER,MOUNTING	4	
03	3066497	6	六角螺栓	SCREW,HEX FLANGE HEAD CA	4	
03	3088317	3	锁紧片	LOCKPLATE	4	
02	3016139	8	空气跨越联接管	CONNECTION,AIR CROSSOVER	1	
02	3035952		空气跨越管安装	MTG,AIR CROSSOVER	1	
03	127362		平垫圈	WASHER,PLAIN	4	
03	140315	12	抱箍	CLAMP,T BOLT	2	
03	3016142	14	普通软管	HOSE,PLAIN	1	
03	3032161	15	衬垫	GASKET,CONN	1	
03	3035624	13	带垫螺栓	SCREW,CAPTIVE WASHER CAP	2	
03	S 106	C 9	六角螺栓	SCREW,HEXAGON HEAD	2	
03	S 604		弹簧垫圈	WASHER,LOCK	2	
02	3096217		增压器安装	TURBO,MOUNTING	1	
03	206576	17	增压器衬垫	GASKET,TURBOCHAGER	1	
03	219138	18	六角螺母	NUT,REGULAR HEXAGON	4	

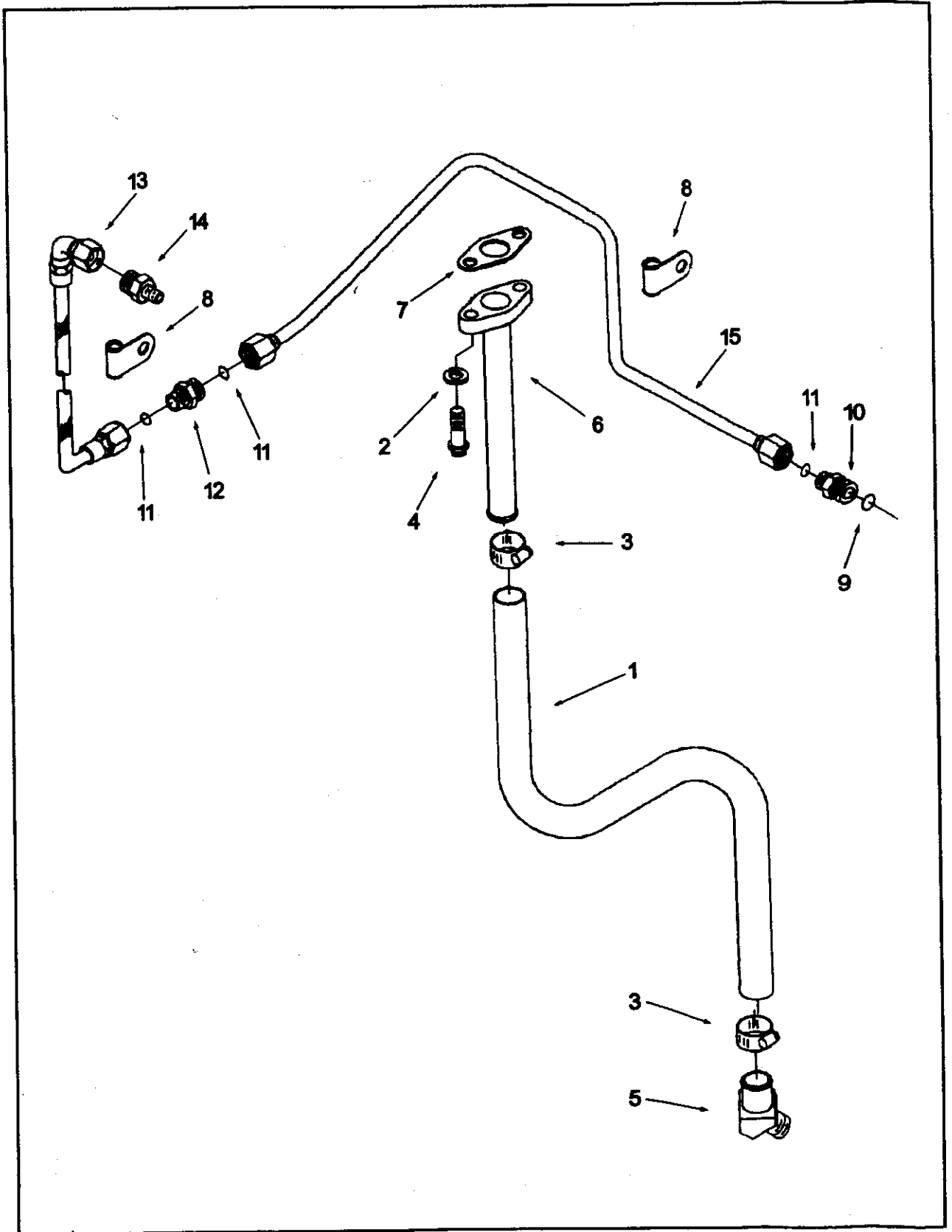

增压器安装

级别	零件号	图上 标号	零件名称		数量	备注
			中文	英文		
02	3003536	5	增压器回油管	ELBOW,TURBO OIL RETURN	1	
02	3096213		增压器回油管及安装	TURBO OIL DRAIN	1	
03	43828	A 3	软管卡箍	CLAMP,HOSE	2	
03	191772	4	十二角螺栓	SCREW,TWELVE POINT	2	
03	3200178	6	增压器回油管	ASSY,TURBO DRAIN	1	
03	3202117	7	衬垫	GASKET,CONNECTION	1	
03	AS16025	NF 1	软管	HOSE,FLEXIBLE	1	
03	S 604	2	弹簧垫圈	WASHER,LOCK	2	
02	3096220		增压器供油管及安装	TURBO OIL SUPPLY	1	
03	3026793	8	夹子	CLIP	2	
03	3081950		阳性弯接头	UNION,MALE	1	
04	3037537	9	O型密封圈	SEAL,O RING	1	
04	3085824	10	阳性接头	UNION,MALE	1	
04	3922794	11	O型圈	SEAL,O RING	1	
03	3086016		阳性接头	UNION,MALE	1	
04	3086040	12	阳形接头	UNION,MALE	1	
04	3922794	11	O型圈	SEAL,O RING	2	
03	3086055	13	柔性软管	HOSE,FLEXIBLE	1	
03	3627697	14	阳性管接头	UNION,MALE	1	
03	3811992	15	增压器供油管	TUBE LUB OIL SUPPLY	1	

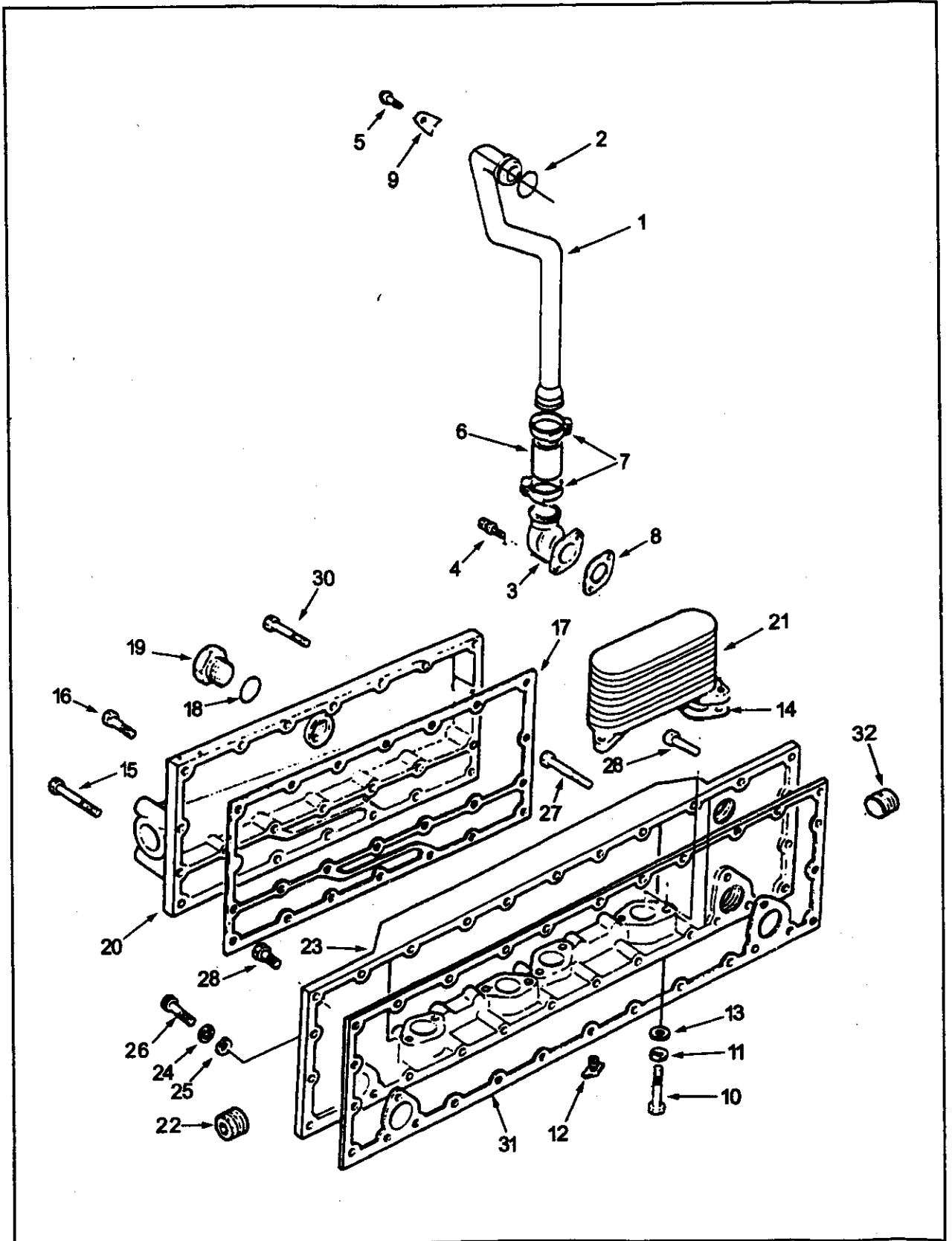

机油冷却器

级别	零件号	图上 标号	零件名称		数量	备注
			中文	英文		
02	3011224	1	旁通水管	TUBE,WATER BYPASS	1	
02	3011763		旁通水管安装	TUBE,WATER BYPASS MTG	1	
03	43828	D 7	管夹	CLAMP,HOSE	2	
03	70624	2	O型密封圈	SEAL,O RING	1	
03	3010299	3	旁通水管接头	CONNECTION,WATER BYPASS	1	
03	3010596	4	带垫圈螺栓	SCREW,CAPTIVE WAS	2	
03	3015283	5	带垫螺栓	SCREW,CAPTIVE WAS	1	
03	3060912	8	旁通水管接头衬垫	GASKET,CONNECTI	1	
03	3063240	6	软管	HOSE,PLAIN	1	
03	3201287	9	夹子	CLIP	1	
02	3201155		机油冷却器总成	COOLER,ENGINE CAST	1	
03	127362	13	平垫圈	WASHER,PLAIN	10	
03	206973	14	冷却器芯衬垫	GASKET,COOLER ELEMENT	4	
03	3012478	15	带垫螺栓	SCREW,CAPTIVE WASHER	2	
03	3037536		螺塞	PLUG,THREADED	3	
04	3037537		O型密封圈	SEAL,O RING	1	
04	3040813	3 2	螺塞	PLUG,THREADED	1	
03	3042889	16	螺栓	SCREW,CAPTIVE W	7	
03	3065791	17	变扭器冷却器衬垫	GASKET,TOR CNV OIL COOLE	1	
03	3078053	10	带垫螺栓	SCREW,CAPTIVE WASHER	8	
03	3085955	23	机油冷却器壳	HOUSING,OIL COOLER	1	
03	3090241	20	机油冷却器盖	COVER,LUB OIL COOLER	1	
03	3165999	12	放水开关	DRAIN,COCK	1	
03	3200781		放水塞	PLUG,HEATER HOLE	1	
04	145540	18	O型密封圈	SEAL,O RING	1	
04	206256	19	放水塞	PLUG,DRAIN	1	
03	3202101	22	螺塞	PLUG,THREADED	2	
04	3046943		O型密封圈	SEAL,O RING	1	
04	3050897		螺塞	PLUG,THREADED	1	
03	3331668	21	冷却器芯	CORE,COOLER	2	
02	3201192		机油冷却器安装	COOLER,MTG	1	
03	127362	25	平垫圈	WASHER,PLAIN	4	
03	205275	26	十二角螺栓	SCREW,TWELVE POINT CAP	4	
03	3033038	27	带垫螺栓	SCREW,CAPTIVE WASHER	2	
03	3040838	28	带垫螺栓	SCREW,CAPTIVE WAS	10	
03	3042890	30	螺栓	SCREW,CAPTIVE W	14	
03	3065790	31	机油冷却器壳衬垫	GASKET,LUB OIL CLR HSG	1	
03	S 604	24	弹簧垫圈	WASHER,LOCK	4	

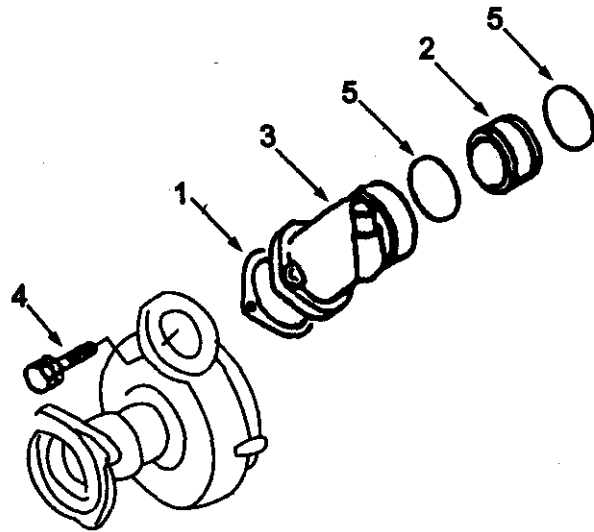

级别	零件号	图上 标号	零件名称		数量	备注
			中文	英文		
02	AR45710		出水管接头	CONNECTION,WTR OUTLET	1	
03	205289	1	出水接头衬垫	GASKET,WTR OUTLET CONN	1	
03	206998	2	输水管	TUBE,WATER TRANSFER	1	
03	3002192	3	出水管接头	CONNECTION,WATER OUTLET	1	
03	3010596	4	带垫圈螺栓	SCREW,CAPTIVE WAS	2	
03	3028291	5	O型密封圈	SEAL,O RING	2	

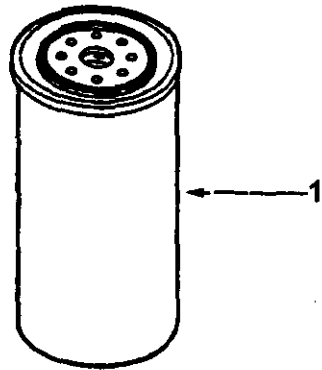

级 别	零 件 号	图 上 标 号	零 件 名 称		数 量	备 注
			中 文	英 文		
02	3100309	1	水 滤 器	ELEMENT,CRN RESISTOR	1	
02	3318320		水 滤 器 防 腐 剂	INHIBITOR,CORROSION	1	

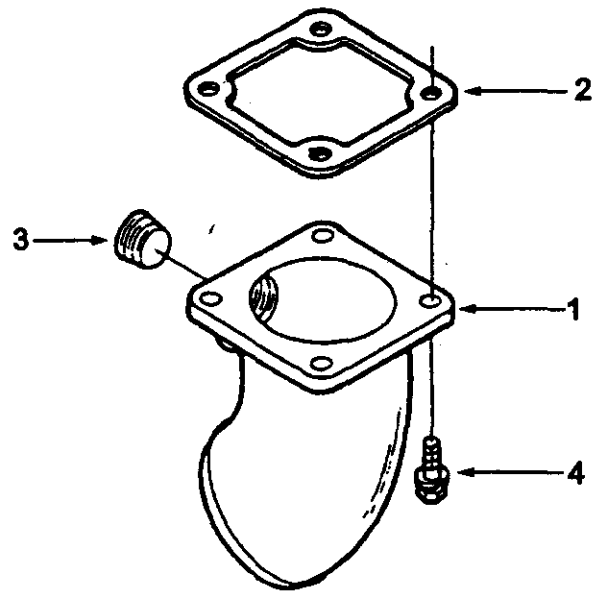

级别	零件号	图上 标号	零件名称		数量	备注
			中文	英文		
02	3001351	1	进水管接头	CONN,WATER INLET	1	
02	3023983		进水管安装	MTG,WATER INLET	1	
03	205288	2	进水管衬垫	GASKET,WTR INLET	1	
03	3008470	3	管塞	PLUG,PIPE	1	
03	3010596	4	带垫圈螺栓	SCREW,CAPTIVE WAS	4	

输水管

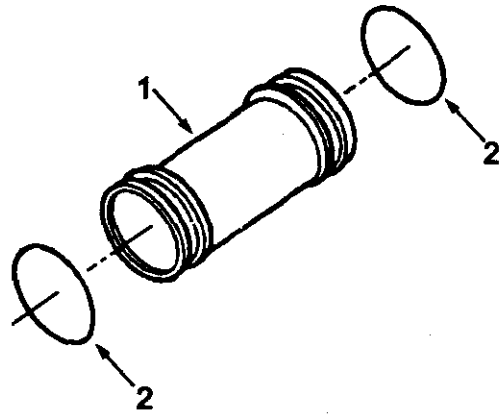

级别	零件号	图上 标号	零件名称		数量	备注
			中文	英文		
02	AR12333		输水管	TUBE,WATER TRANS	5	
03	207233	1	输水管	TUBE,WATER TRANSF	1	
03	3028291	2	O型密封圈	SEAL,O RING	2	

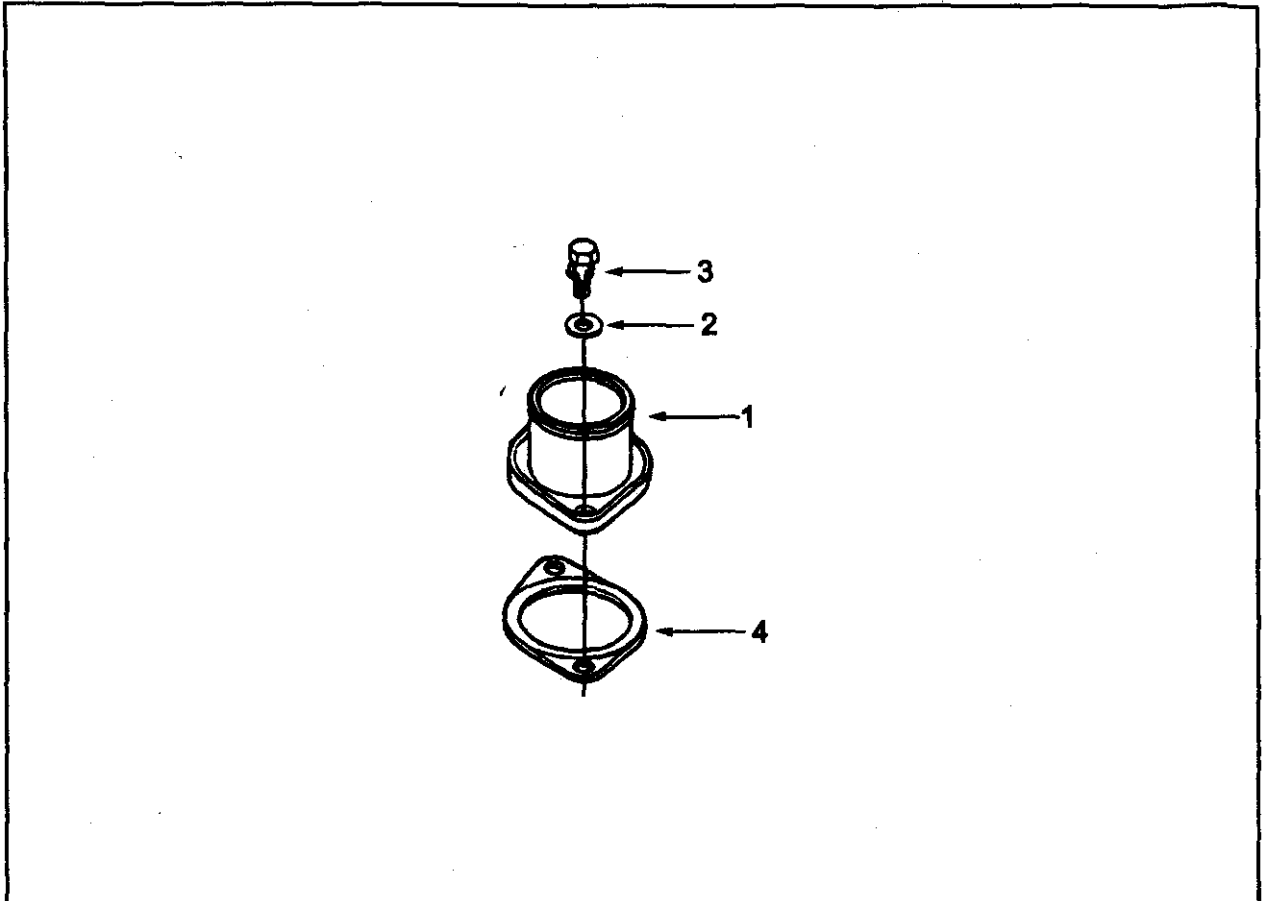

级别	零件号	图上 标号	零件名称		数量	备注
			中文	英文		
02	208060	1	出水接头	CONNECTION,WATER	2	
02	MP 5003		出水接头安装	CONNECTION,WATER	2	
03	3010596	3	带垫圈螺栓	SCREW,CAPTIVE WAS	4	
03	3165360	4	出水管接头衬垫	GASKET,CONNECTI	1	

级 别	零 件 号	图 上 标 号	零 件 名 称		数 量	备 注
			中 文	英 文		
02	3098960		水泵	PUMP,WATER	1	总成装配
03	145623	1	O型密封圈	SEAL,O RING	1	
03	3005594	2	平垫圈	WASHER,PLAIN	2	
03	3010529		进水接头	CONNECTION,WATER INLET	1	
04	S 114	3	六角螺栓	SCREW,HEXAGON HEAD CAP	1	
04	S 600	4	弹簧垫圈	WASHER,LOCK	1	
04	S 631	5	平垫圈	WASHER,PLAIN	1	
04	205363	6	弹簧垫圈	WASHER,SPRING	1	
04	206963	7	滤清器连接接头	ADAPTER,FILTER HEAD	1	
04	3008466	8	管塞	PLUG,PIPE	1	
04	3008469	9	管塞	PLUG,PIPE	1	
04	3010181	10	进水接头	CONNECTION,WATER INLET	1	
04	3010536	14	截断阀轴	SHAFT,SHUTOFF VALVE	1	
04	3010704	11	输水管	TUBE,WATER TRANSFER	1	
04	3201982	12	阳性接头	CONNECTOR,MALE	1	
04	3201983	13	阳性接头	ELBOW,MALE ADAPTER	1	
04	3818885	15	O型密封圈	SEAL,O RING	1	
03	3010596	16	带垫螺栓	SCREW,CAPTIVE WASHER CAP	3	
03	3012472	17	带垫螺栓	SCREW,CAPTIVE WASHER CAP	1	
03	3012474	18	带垫螺栓	SCREW,CAPTIVE WASHER CAP	1	
03	3036096	29	水泵支撑	BRACE,WATER PUMP	1	
03	3098961		水泵	PUMP,WATER	1	
04	3165998	19	放水开关	DRAINCOCK	1	
04	S 16002	20	滚珠轴承	BEARING,BALL	1	
04	S 16069	21	滚珠轴承	BEARING,BALL	1	
04	70183	22	卡环	RING,RETAINING	1	
04	205243	28	水泵叶轮	IMPELLER,WATER PUMP	1	
04	205258	23	卡环	RING,RETAINING	1	
04	206948	24	油封	SEAL,OIL	1	
04	206964	25	水泵体	BODY,WATER PUMP	1	
04	3042827	27	水泵轴	SHAFT,WATER PUMP	1	
05	205158		水泵轴	SHAFT,WATER PUMP	1	
05	3040833		水泵轴	SHAFT,WATER PUMP	1	
04	3609826	26	水泵水封	SEAL,WATER PUMP	1	

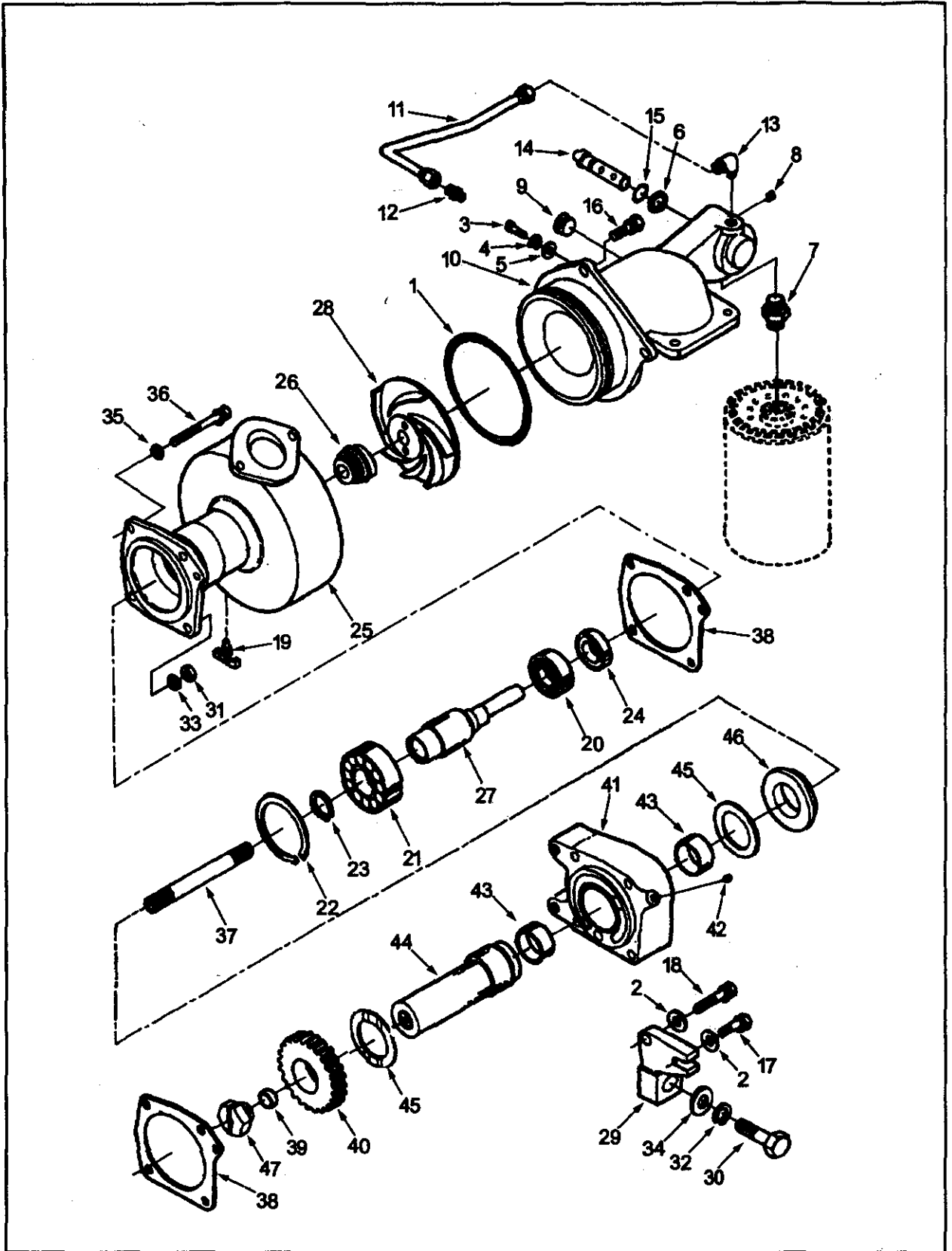

级 别	零 件 号	图 上 标 号	零 件 名 称		数 量	备 注
			中 文	英 文		
02	3088377		水泵安装	PUMP,WATER MTG	1	
03	127362	35	平垫圈	WASHER,PLAIN	3	
03	3012476	36	带垫螺栓	SCREW,CAPTIVE WAS	3	
03	3202007	37	水泵轴	SHAFT,WATER PUMP	1	
03	3202283	38	水泵衬垫	CASKET,WATER PUMP	2	
03	S 103	A 30	六角螺栓	SCREW,HEXAGON HEAD	1	
03	S 205	31	六角螺母	NUT,REGULAR HEXAGON	1	
03	S 603	32	弹簧垫圈	WASHER,LOCK	1	
03	S 604	33	弹簧垫圈	WASHER,LOCK	1	
03	S 658	34	平垫圈	WASHER,PLAIN	1	
02	3200968	47	螺塞	PLUG,THREADED	1	
02	3410054		水泵轴	SHAFT,WATER PUMP	1	
03	205498	39	油塞	PLUG,OIL	1	
03	207251	40	水泵齿轮	GEAR,WATER PUMP	1	
03	3025887	44	水泵轴	SHAFT,WATER PUMP	1	
03	3026556	45	止推轴承	BEARING,THRUST	2	
03	3034721	46	水泵轴轴用卡环	RETAINER,SHAFT	1	
03	3086177		水泵支撑	SUPPORT,WATER PUMP	1	
04	205156	43	衬套	BUSHING	2	
04	3056416		螺塞	PLUG,THREADED	1	
05	3056003		螺塞	PLUG,THREADED	1	
05	3056415		O型密封圈	SEAL,O RING	1	
04	3086178	41	水泵支撑	SUPPORT,WATER PUMP	1	

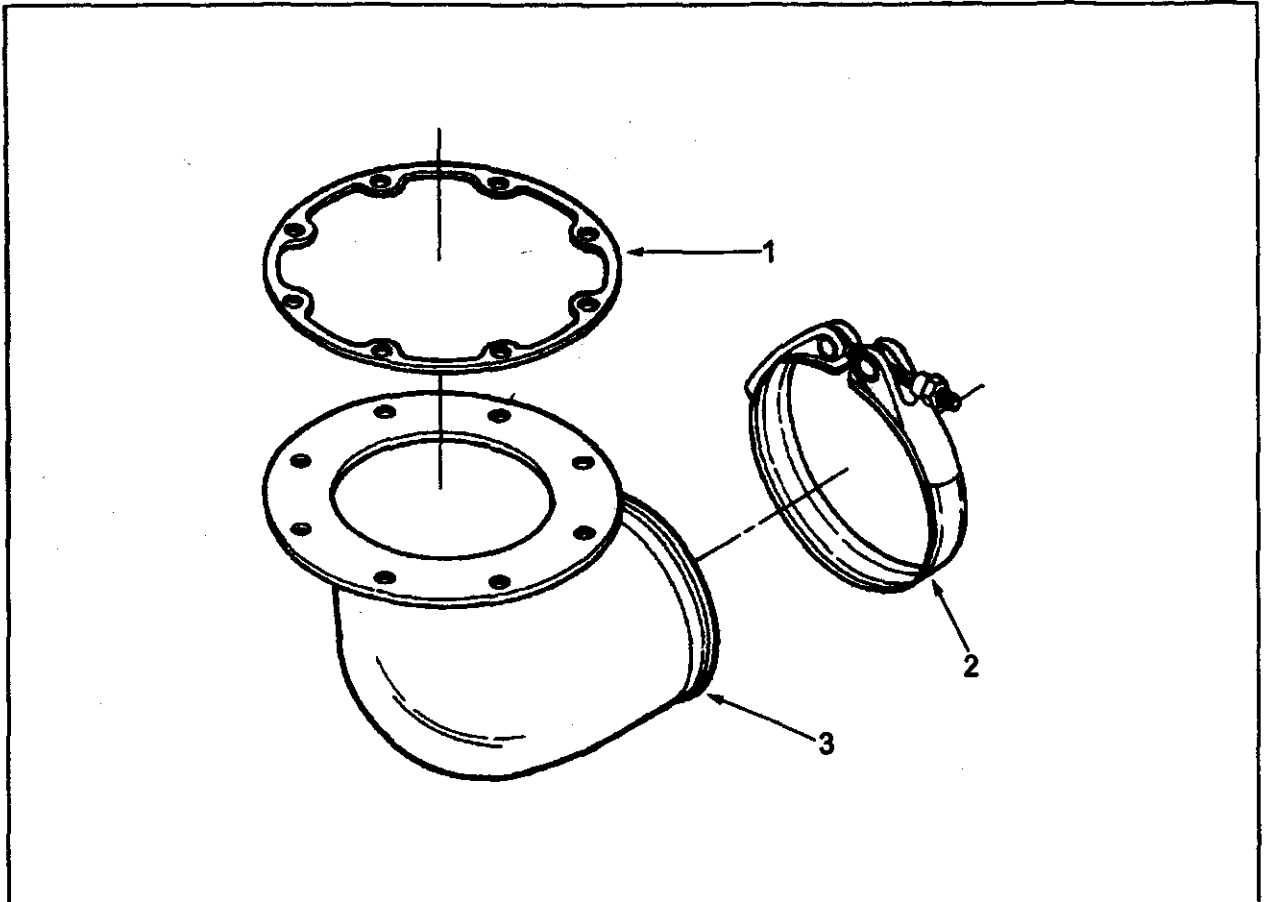

级别	零件号	图上 标号	零件名称		数量	备注
			中文	英文		
02	106322	1	衬垫	GASKET,TURBOCHARGER	1	
02	3026447		增压器管接头	CONNECTION,TURBO	1	
03	201989	2	抱箍	CLAMP,V BAND	1	
03	3026237	3	排气管接头	CONN,EXHAUST OUTLET	1	

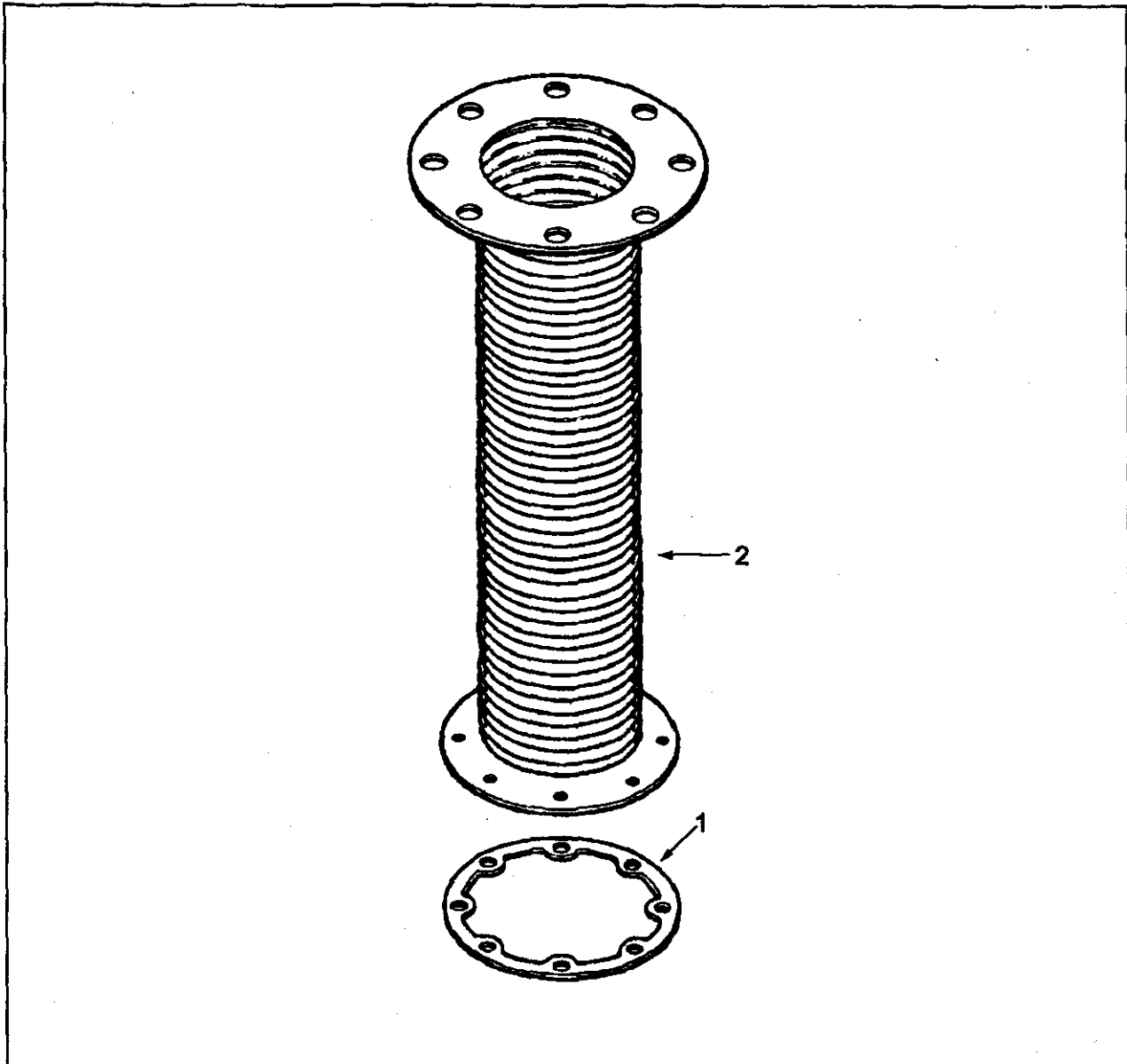

级别	零件号	图上 标号	零件名称		数量	备注
			中文	英文		
02	106322	1	衬垫	GASKET,TURBOCHARGER	1	
02	203555	2	排气波纹管	CONNECTION,EXHAUST OUTLE	1	

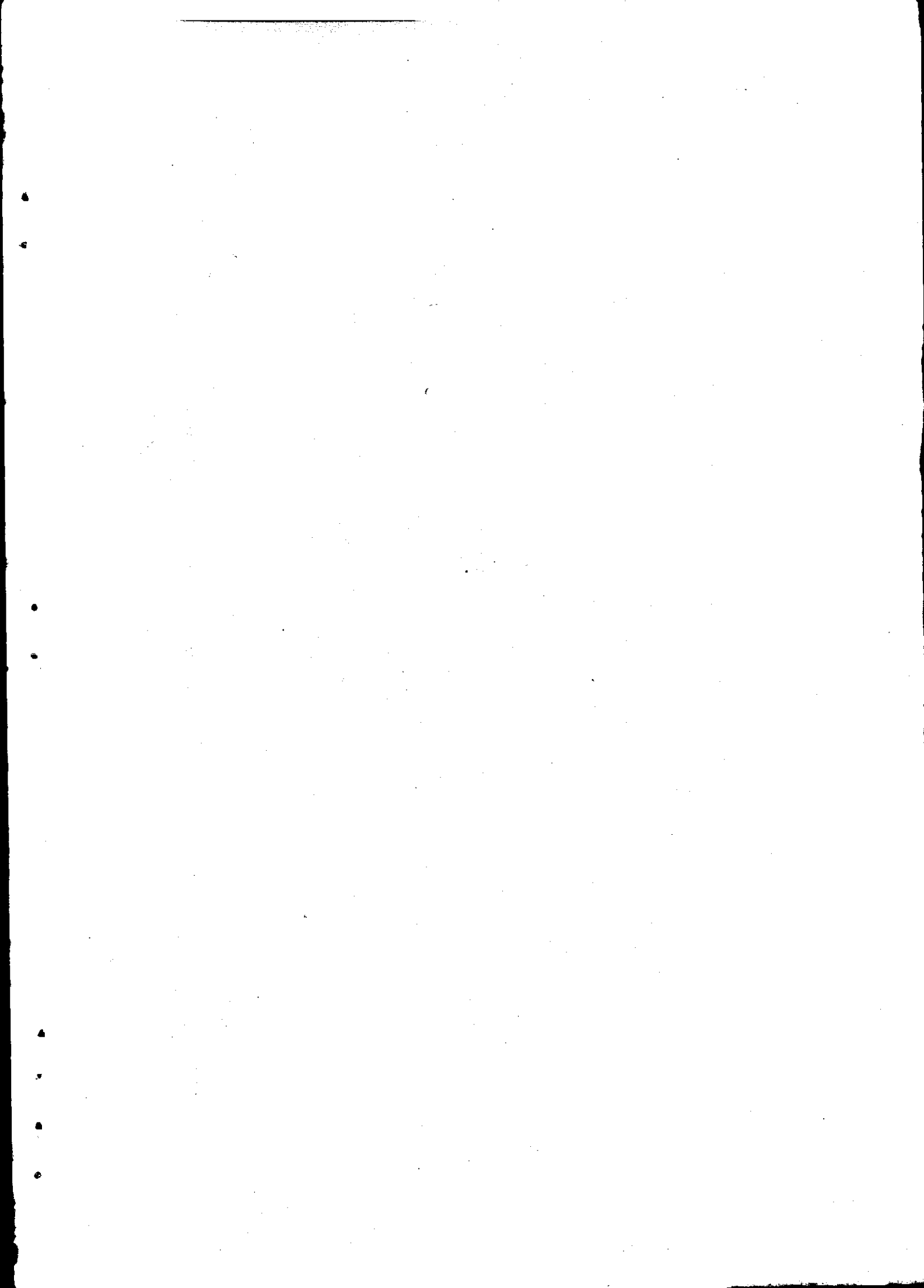

地 址：重庆市沙坪坝区壮志路（烈士墓）
电 话：023-65335888（总机）
023-65333444（服务热线）
电 报：0221（重庆）
传 真：023-65315379
邮 编：400031
零件号：3166155-00
CCEC 文印中心印刷

ADD:ZHUANGZHI ROAD,SHAPINGBA, CQ
PHONE:023-65335888
023-65333444
CABLE:0221(CQ)
Fax:023-65315379
P.C:400031
PARTS NO:3166155-00

本图册如有更改，恕不通知！