

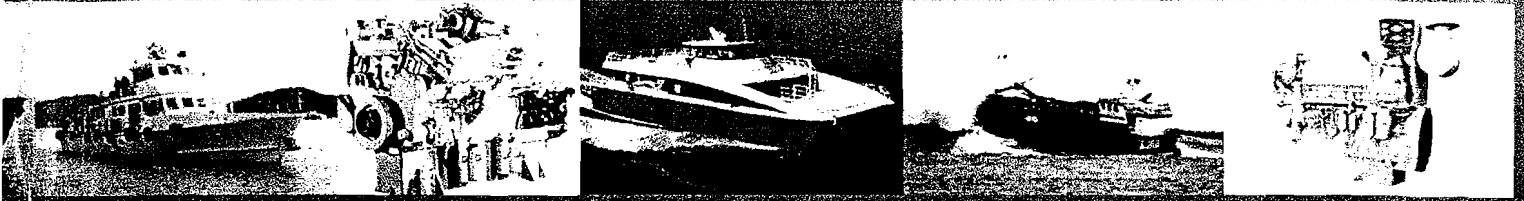

KTA19-G(M) 零件目录

适用机型 KTA19-G2(M)/G3(M)/G4(M)



重庆康明斯发动机有限公司

CHONGQING CUMMINS ENGINE COMPANY Ltd.

重庆康明斯发动机零件图册
适用机型 KTA19-G2(M)、G3(M)、G4(M)

使用 说 明

本图册是根据公司 KTA19-G (M)发动机配船用 G 驱动需要编制的发动机图册，它以直观的形式显现出了发动机的易损零件和一般零件。是用户选购零部件指导性的资料。

随着发动机的不断改进，图册所示零件号和实际装配零件号可能有出入，请用户在选购零件时尽可能提供以下情况：

- 一. 发动机铭牌或合格证上的机型和生产指令号 (S.O)、以及发动机出厂序号。
- 二. 写明图册中的图册零件号 (最好注明页次)。

我厂可根据用户提供的以上资料，查到对应的实际零件号。

用户在使用此图册过程中，如有问题，可随时向我公司提出，我们会尽快的作出答复。

联系电话：023-65335888- 设计处

重庆康明斯发动机有限公司

2004 年 5 月

目 录 TABLE OF CONTENTS

标题	TITLE	页次 PAGE NO.
空气滤清器	AIR CLEANER	1
正时轮盘	TIMING DISK	3
发电机皮带轮	ALTERNATOR PULLEY	5
气缸体	CYLINDER BLOCK	7、9
中间齿轮	IDLER GEAR	11
曲轴和主轴瓦	CRANKSHAFT & MAIN BEARINS	13
摇臂	ROCKER LEVER	15
凸轮轴从动件	CAM FOLLOWER	17、19
机油泵	LUB OIL PUMP	21
曲轴箱通风器	BREATHER LOCATION	23
空气阻力指示器	RESTRICTION INDICATOR	25
减振器	VIBRATION DAMPER,	26
发动机导线	ENGINE WIRING	27
油压报警开关	LOW OIL PRESSURE SWITCH	28
水温报警开关	COOLANT TEMPERATURE SWITCH	29
发电机安装	ALTERNATOR MOUNTING	30
发电机	ALTERNATOR	31
齿轮室盖	FRONT ENGINE SUPPORT	33
齿轮室盖安装	GEAR COVER MOUNTING	35
仪表箱	INSTRUMENT PANEL	37
仪表板	INSTRUMENT PANEL	39
磁力开关	MAGNETIC SWITCH	41
燃油滤清器	FUEL FILTER	43
燃油滤清器管路	FUEL FILTER PLIMSING	45
飞轮壳	FLYWHEEL HOUSING	47
电磁传感器	MAGNETIC PICKUP	49
加机油口	OIL FILL LOCATION	50
控制器	CUMMINS EFC GOVERNOR	51
附件驱动	FUEL PUMP DRIVE	52
燃油泵	FUEL PUMP	53
燃油管路	FUEL TUBING	55、57、59、61
飞轮	FLYWHEEL	63
液压泵法兰盖	COVE PLATE	64
热交换器	HEAT EXCHANGER	65、67

目 录 TABLE OF CONTENTS

标题	TITLE	页次 PAGE NO.
进气管	INTAKE MANIFOLD	69
进气管安装	INTAKE MANIFOLD MOUNTING	71
节温器壳	THERMOSTAT HOUSING ASSY	73
机油滤清器	LUB OIL FILTER	75
机油尺	OIL LEVEL GAUGE	77
手孔盖	HAND HOLE COVERS	78
机油旁通滤清器	BYPASS OIL FILTER	79
机油旁通滤清器管路	OIL BYPASS FILTER PLUMBING	80
机油盘	OIL PAN	81
机油盘安装	MTG OIL PAN	83
活塞和连杆	PISTON AND CONNROD	85、87
凸轮轴和齿轮	CAMSHAFT AND GEAR	89、90、91
中冷器芯	AFTERCOOLER CORE	92
气缸盖	CYLINDER HAND	93、95
气缸盖安装	CYLINDER HAND MOUNTING	97
喷油器	INJECTOR	99、101、103
增压器	TURBOCHARGER	105、107、109
减振器和发电机防护罩	DAMPER ALTERNATOR GUAR	111
摇臂室	ROCKER HOUSING	113、114
起动机	STARING MOTOR	115
海水泵	RAW WATER PUMP	117
排气管	EXHAUST MANIFOLD	119、121
增压器安装	TURBO MOUNTING	123、125
机油冷却器	OIL COOLER	127
机油冷却器接头	OIL COOLER CONNECTION	129
水滤器	CORROSION RESISTOR	130
进水管接头	WATER INLET CONNECTION	131
水管总成	WATER MANIFOLD	133、135
出水接头	WATER OUTLET CONNECTION	136
水泵	WATER PUMP	137、139
排气弯接头	EXHAUST EXPANSION ADAPT	142
排气波纹管	FLEX EXHAUST TUBING	143
排气接头	EXHAUST EXPANSION ADAPT	144
排气消声器	MUFFULER	145

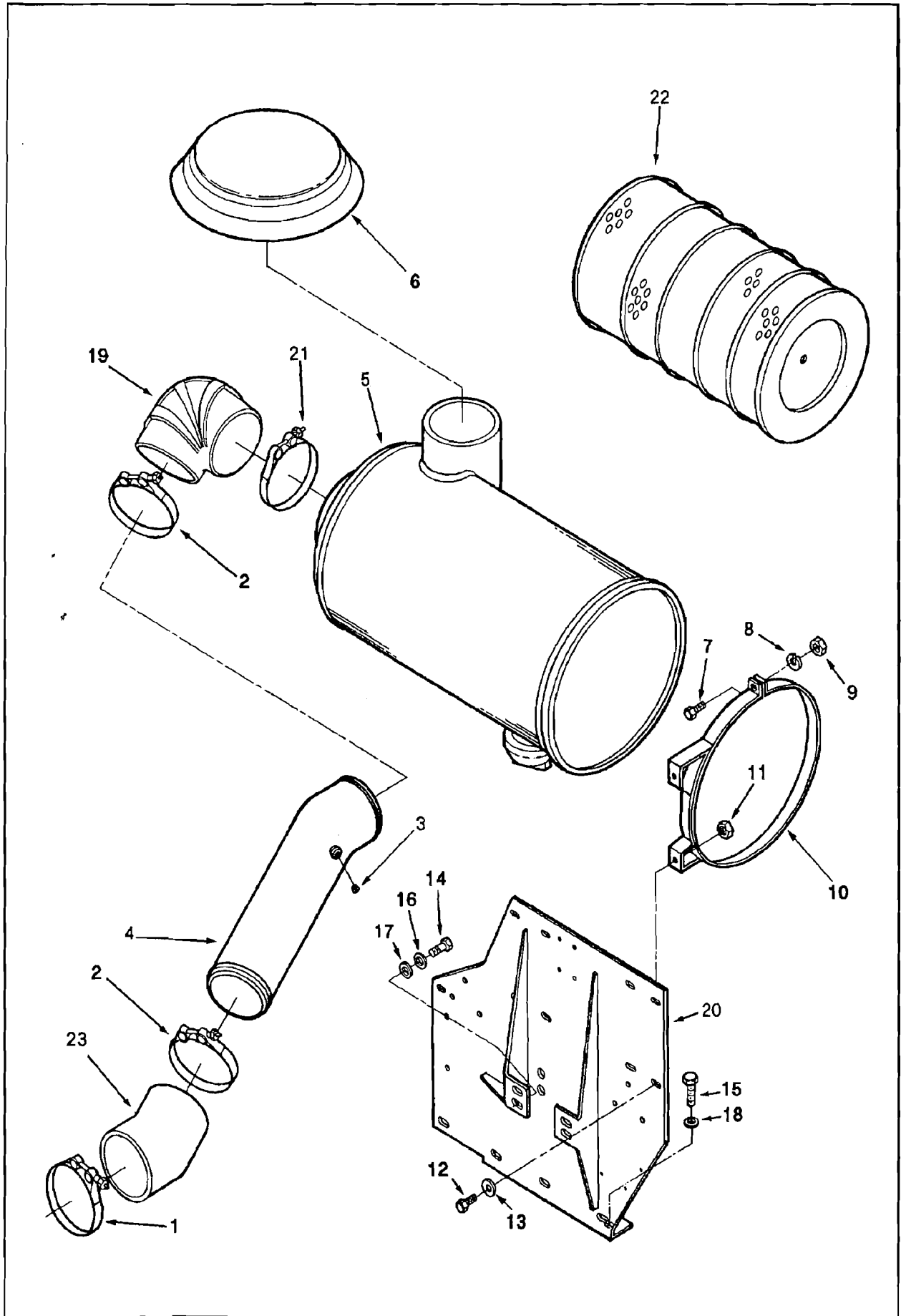

表—01

空气滤清器 Air Cleaner

AC 4040

级别 LV	零件号 Part Number	图上标号 Ref No	零件名称 Part Name		数量 Req	备注 Remarks
			中文	英文		
02	125741	1	T型卡箍	CLAMP, T BOLT	1	
02	140313	2	T型卡箍	CLAMP, T BOLT	2	
02	3001870	4	进气管	TUBE, AIR INLET	1	
02	3017002		空气滤清器	CLEANER, AIR	1	
	(3018042)	22	空气滤清器芯	ELEMENT, AIR CLEANER	1	
	(3165205)	5	空气滤清器壳	HOUSING, AIR CLEANER	1	
02	3017003	6	空滤器盖	CAP, AIR CLEANER	1	
02	3025458	3	管塞	PLUG, PIPE	1	
02	3030514	19	软管	HOSE, ELBOW	1	
02	3030782	23	软管	HOSE, ELBOW	1	
02	3034735	20	空滤器支架	BRACKET, AIR CLEANER	1	
02	3175623	21	T型螺栓卡箍	CLMP, T BOLT	1	
02	4067603		箍带安装	MTG, STRAPS	1	
03	69832	9	六角螺母	NUT, REGULER HEXAGON	2	
03	197221	10	空滤器箍带	STRAP, AIR. CLEANER	2	
03	S 111	7	六角螺栓	SCREW, HEXAGON HEAD	2	
03	S * 605	8	弹簧垫圈	WASHER, LOCK	2	
02	3022323		空滤器安装	MTG, AIR CLEANER	1	
03	103023	12	六角螺栓	SCREW, HEXAGON HEAD CAP	4	
03	3000082	13	平垫圈	WASHER, PLAIN	4	
03	S 217	11	六角厚螺母	NUT, HEAVY HEXAGON	4	
02	3022325		空滤器支架安装	MTG, SUPPORT	1	
03	108330	16	平垫圈	WASHER, PLAIN	4	
03	203310	18	平垫圈	WASHER, PLAIN	2	
03	S 109	14	六角螺栓	SCREW, HEXAGON HEAD CAP	4	
03	S 145	15	六角螺栓	SCREW, HEXAGON HEAD	2	

级别
LV
02
03
03
02
03
03

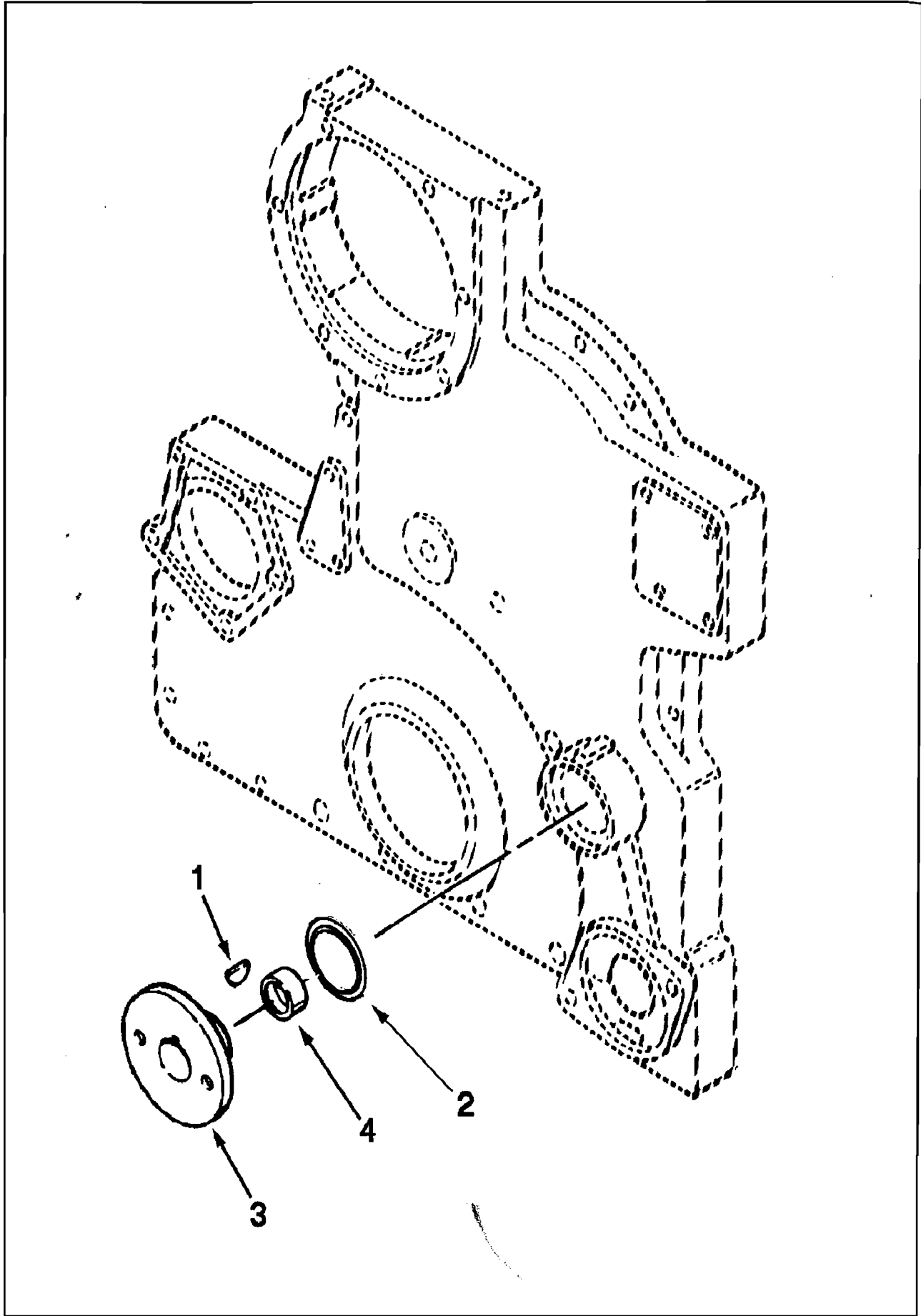

级别 LV	零件号 Part Number	图上标号 Ref No	零件名称 Part Name		数量 Req	备注 Remarks
			中文	英文		
02	3007111		附件驱动皮带轮	HUB, TIMING	1	
03	3007301	3	附件驱动皮带轮	HUB, TIMING	1	
03	190397	4	耐磨套	SLEEVE, WEAR	1	
02	MP 4986		发电机皮带轮安装	PULLEY, ACCESSORY MTG	1	
03	3200287	2	键槽密封圈	SEAL, KEYWAY	1	
03	S 316	1	半园键	KEY, PLAIN WOODRUFF	1	

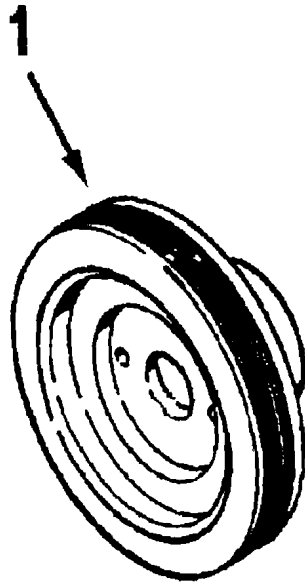

级别 LV	零件号 Part Number	图上标号 Ref No	零件名称 Part Name		数量 Req	备注 Remarks
			中文	英文		
02	3002331	1	发电机皮带轮	PULLEY, ATLERNATOR	1	

记录

注
rks

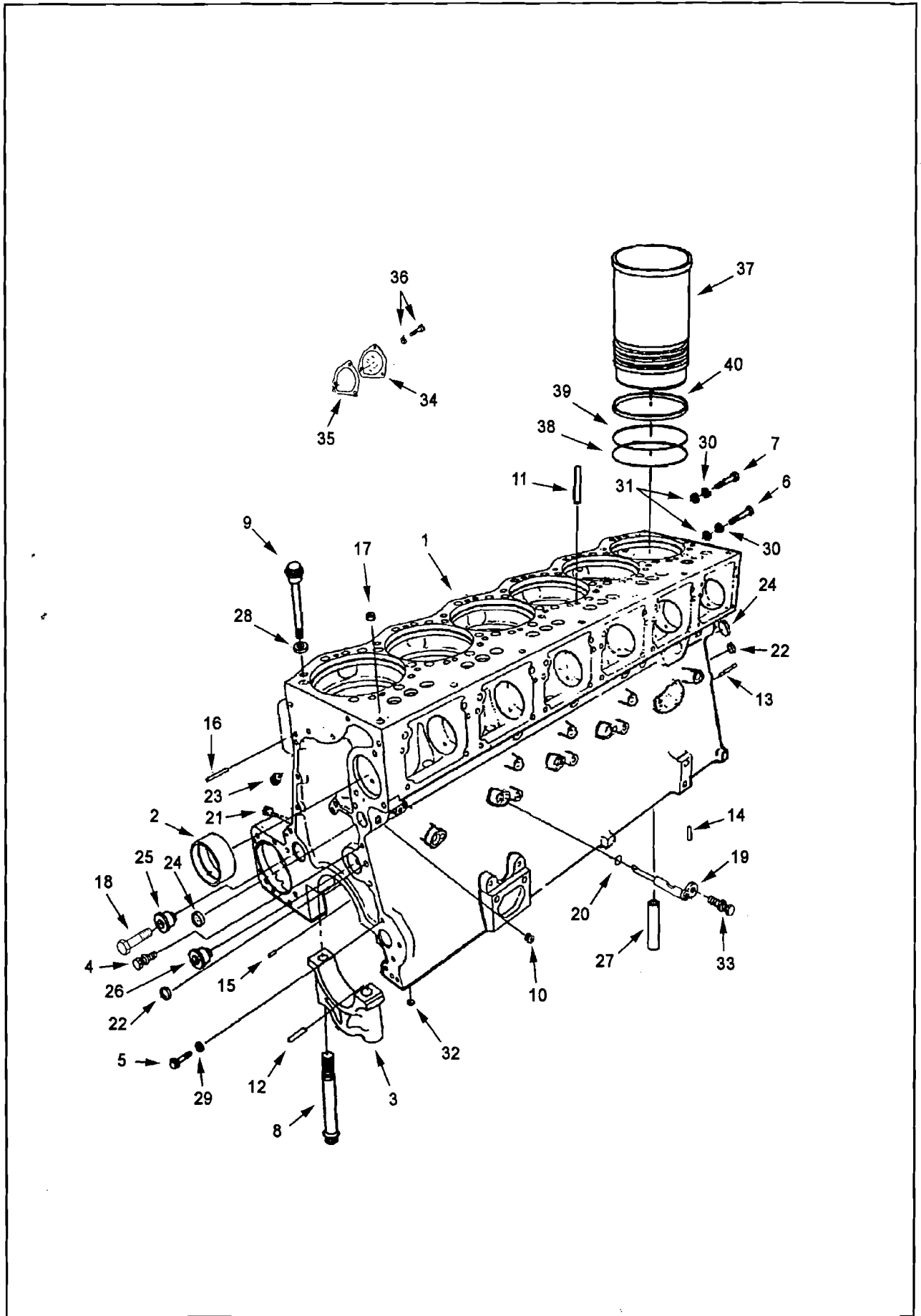

级别 LV	零件号 Part Number	图上标号 Ref No	零件名称 Part Name		数量 Req	备注 Remarks
			中文	英文		
02	3044517		气缸体总成	BLOCK, CYLINDER	1	
03	147416	22	碗形塞	PLUG, EXPANSION	2	
03	175830	24	碗形塞	PLUG, EXPANSION	2	
03	3007632	17	碗形塞	PLUG, EXPANSION	8	
03	3044516		气缸体分总成	BLOCK, CYLINDER	1	
04	67211	14	后主轴承定位销	DOWEL, REAR MAIN	2	
04	124921	15	定位销	DOWEL	2	
04	205021	3	主轴承盖	CAP, MAIN BEARING	4	
04	205022	3	主轴承盖	CAP, MAIN BEARING	1	
04	205023	3	主轴承盖	CAP, MAIN BEARING	1	
04	205075	3	主轴承盖	CAP, MAIN BEARING	1	
04	205298	27	机油输油管	TUBE, LUB OIL TRANSFER	1	
04	3002834	2	衬套	BUSHING	7	
04	3025482	8	十二角螺栓	SCREW, TWELVE POINT CAP	14	
04	3044515	1	气缸体	BLOCK, CYLINDER	1	
02	3028438		气缸体安装	BLOCK, CYLINDER MTG	1	
03	68445	11	带槽圆柱销	PIN, GROOVE	12	
03	3008470	23	管塞	PLUG, PIPE	1	
03	3025458	21	管塞	PLUG, PIPE	1	
03	3025460	10	管塞	PLUG, PIPE	2	
02	3028434		气缸套组件	KIT, LINER	6	
03	3011076	39	O型密封圈	SEAL, D RING	1	
03	3014668	38	O型密封圈	SEAL, D RING	1	
03	3081489	40	缝隙密封圈	SEAL, OIL	1	
03	4009220	37	气缸套	KIT, LINER	1	
02	3200936		活塞冷却喷嘴	NOZZLE, PISTON COO	6	
03	3007517	19	活塞冷却喷嘴	NOZZLE, PISTON COO	1	
	(3015067)	20	O型密封圈	SEAL, D RING	1	
03	3033822	33	带垫圈螺栓	SCREW, CAPTIVE WAS	1	
02	3013962		气缸盖安装	HEAD, CYLINDER MTG	6	
03	205059		平垫圈	NUT, HEAVY HEXAGON	6	
03	3032633	38	十二角螺栓	WASHER, CYLINDER	6	
03	3086362	9	丁字压板	SCREW, TWELVE POINT CAP SCREW, CROSSHEAD ADJUST CROSSHEAD, VALVE	2	

级别 LV	零件号 Part Number	图上标号 Ref No	零件名称 Part Name		数量 Req	备注 Remarks
			中文	英文		
02	3007803		惰齿轮安装	IDLER, GEAR MTG	2	
03	130083		止推轴承	BEARING, THRUST	2	
03	207527	18	十二角螺栓	SCREW, TWELVE POINT	1	
03	3200772		平垫圈	WASHER, PLAIN	1	
03	3202114	25	惰轮轴	SHAFT, IDLER	1	
02	3028968		飞轮壳安装	HOUSING, FLYWHEEL MTG	1	
03	9226	13	飞轮壳定位销	DOWEL, FLYWHEEL HOUSING	2	
03	172648		矩形圈	SEAL, RECTANGULAR RING	14	
03	3096260		矩形密封圈	SEAL, RECTANGULAR RING	1	
03	S 103	A 7	六角螺栓	SCREW, HEXAGON HEAD	10	
03	S 144	6	六角螺栓	SCREW, HEXAGON HEAD	2	
03	S 603	30	弹簧垫圈	WASHER, LOCK	12	
02	3016717		正时齿轮室板安装	MTG, GEAR COVER	1	
03	70645	12	主定位销	DOWEL PIN	1	
03	102957	16	定位销	DOWEL, DIAMOND	1	
03	3014766	4	带垫螺栓	SCREW, CAPTIVE WASHER CAP	12	
03	3410141		衬垫	GASKET, COVER PIAT	1	
02	207373	34	凸轮轴端盖	COVER, CAMSHAFT	1	
02	MP 4981		凸轮轴盖安装	COVER CAMSHAFT MTG	1	
03	3014766	36	带垫螺栓	SCREW, CAPTIVE WASHER CAP	3	
03	3040722	35	凸轮轴盖衬垫	GASKET, CAMSHAFT COVER	1	

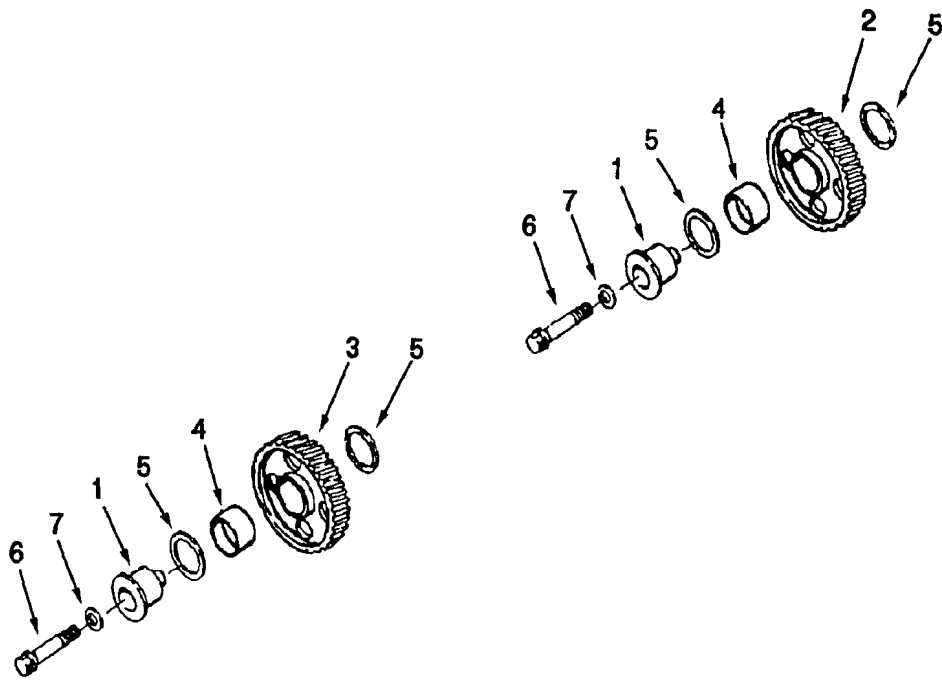

级别 LV	零件号 Part Number	图上标号 Ref No	零件名称 Part Name		数量 Req	备注 Remarks
			中文	英文		
02	3004684		凸轮轴中间齿轮	GEAR, BUSHING CAM IDLER	1	
	(3004599)	2	凸轮轴中间齿轮	GEAR, IDLER	1	
	(3004686)	4	衬套	BUSHING	1	
02	3004685		水泵中间齿轮	GEAR, BUSHING WTR IDLER	1	
	(3004680)	3	水泵中间齿轮	GEAR, IDLER	1	
	(3004686)	4	衬套	BUSHING	1	
02	3007803		惰齿轮安装	IDLER, GEAR MTG	2	
03	130083	5	止推轴承	BEARING, THRUST	2	
03	207527	6	十二角螺栓	SCREW, TWELVE POINT	1	
03	3200772	7	平垫圈	WASHER, PLAIN	1	
03	3202114	1	惰轮轴	SHAFT, IDLER	1	

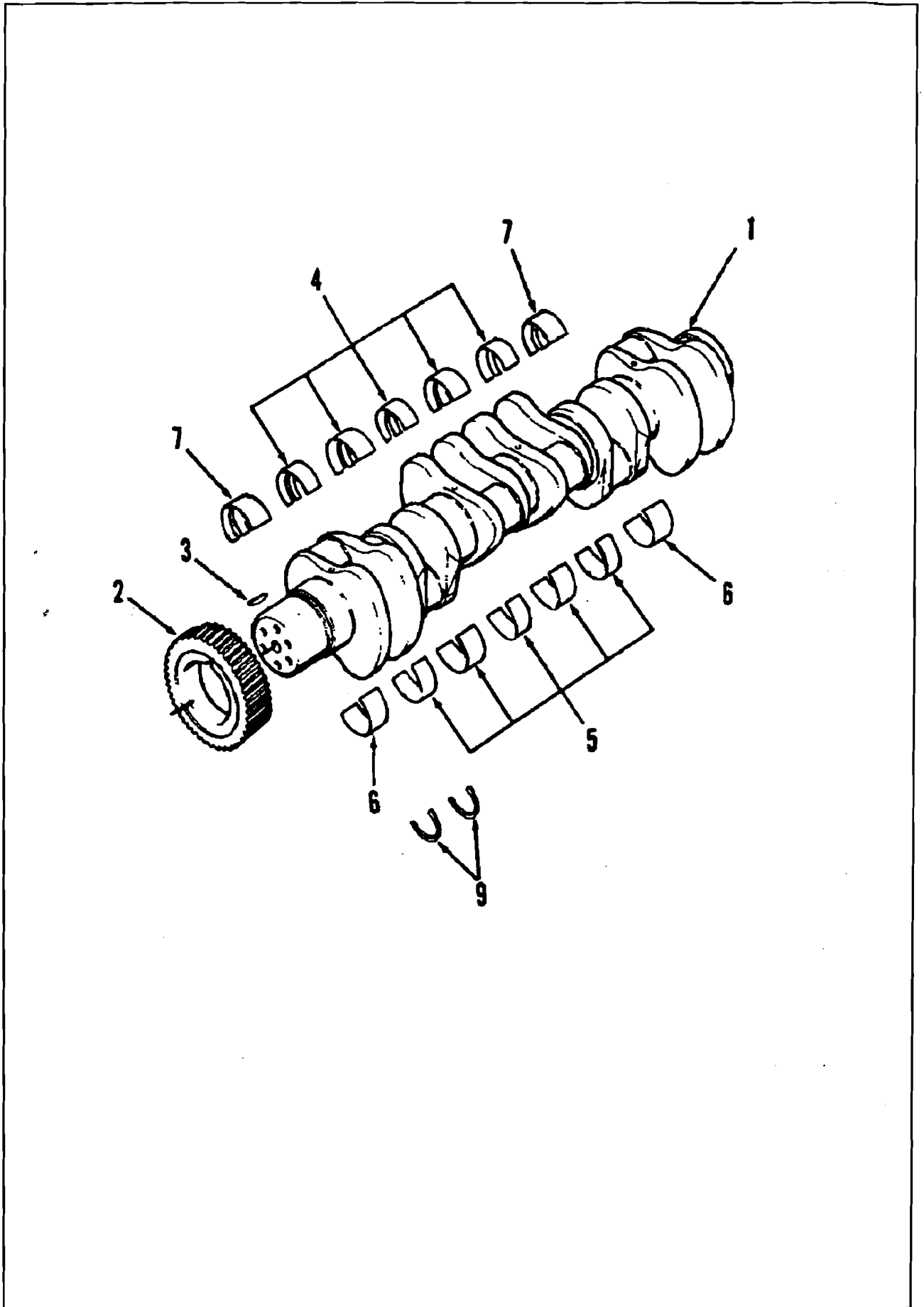

级别 LV	零件号 Part Number	图上标号 Ref No	零件名称 Part Name		数量 Req	备注 Remarks
			中文	英文		
02	3418910		曲轴总成	CRANKSHAFT	1	
03	206904	3	半圆键	KEY, WOODRUFF	1	
03	207259	2	曲轴齿轮	GEAR, CRANKSHFT	1	
03	3418898	1	曲轴	CRANKSHAFT	1	
02	AR12270		主轴瓦组	SHELL, MAIN BEARIN	1	标准
03	205112	9	止推轴承	BEARING, THRUST	4	
03	205140	4	主轴瓦	BEARING, MAIN	5	第2, 3, 4, 5, 6上瓦
03	205150	5	主轴瓦	BEARING, MAIN	5	第2, 3, 4, 5, 6下瓦
03	205160	6	主轴瓦	BEARING, MAIN	2	第1, 7下瓦
03	205170	7	主轴瓦	BEARING, MAIN	2	第1, 7上瓦
02	AR12271		主轴瓦组	SHELL, MAIN BEARIN	1	加厚0.10英寸
03	205112	9	止推轴承	BEARING, THRUST	4	
03	205141	4	主轴瓦	BEARING, MAIN	5	第2, 3, 4, 5, 6上瓦
03	205151	5	主轴瓦	BEARING, MAIN	5	第2, 3, 4, 5, 6下瓦
03	205161	6	主轴瓦	BEARING, MAIN	2	第1, 7下瓦
03	205171	7	主轴瓦	BEARING, MAIN	2	第1, 7上瓦
02	AR12272		主轴瓦组	SHELL, MAIN BEARIN	1	加厚0.20英寸
03	205112	9	止推轴承	BEARING, THRUST	4	
03	205142	4	主轴瓦	BEARING, MAIN	5	第2, 3, 4, 5, 6上瓦
03	205152	5	主轴瓦	BEARING, MAIN	5	第2, 3, 4, 5, 6下瓦
03	205162	6	主轴瓦	BEARING, MAIN	2	第1, 7下瓦
03	205172	7	主轴瓦	BEARING, MAIN	2	第1, 7上瓦
02	AR12273		主轴瓦组	SHELL, MAIN BEARIN	1	加厚0.30英寸
03	205112	9	止推轴承	BEARING, THRUST	4	
03	205143	4	主轴瓦	BEARING, MAIN	5	第2, 3, 4, 5, 6上瓦
03	205153	5	主轴瓦	BEARING, MAIN	5	第2, 3, 4, 5, 6下瓦
03	205163	6	主轴瓦	BEARING, MAIN	2	第1, 7下瓦
03	205173	7	主轴瓦	BEARING, MAIN	2	第1, 7上瓦
	3001196	9	止推轴承	BEARING, THRUST	4	加厚0.10英寸
	3001197	9	止推轴承	BEARING, THRUST	4	加厚0.20英寸

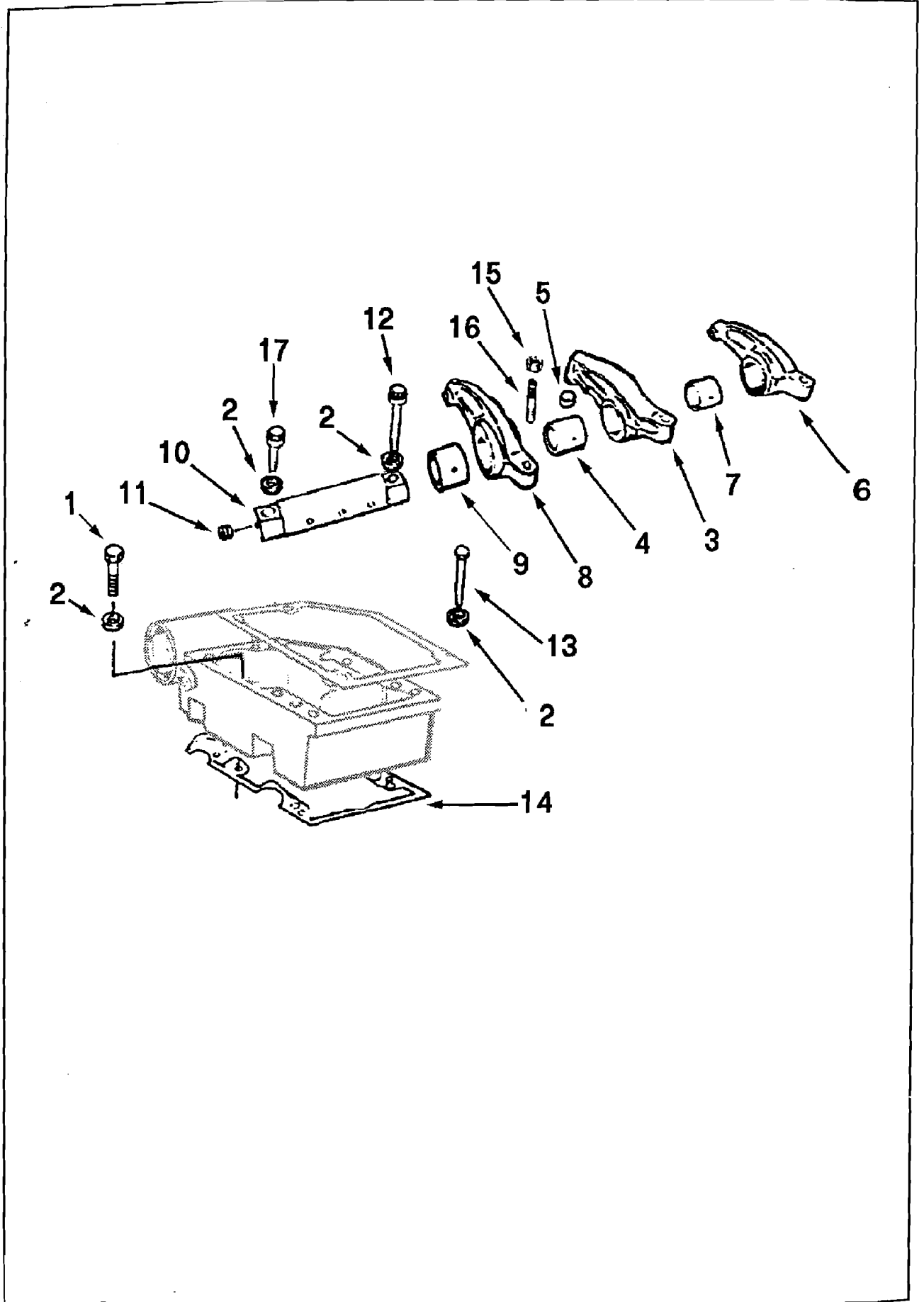

级别 LV	零件号 Part Number	图上标号 Ref No	零件名称 Part Name		数量 Req	备注 Remarks
			中文	英文		
02	3065810		摇臂总成	LEVER,ROCKER	6	
03	168306	16	开槽调节螺栓	SCREW,SLOTTED SET	3	
03	3053476		摇臂	LEVER,ROCKER	1	
04	207344	7	衬套	BUSHING	1	
04	208084		铆钉	RIVTE	1	
04	3418857	6	摇臂	LEVER,ROCKER	1	
03	3053477		摇臂	LEVER,ROCKER	1	
04	207344	9	衬套	BUSHING	1	
04	208084		铆钉	RIVTE	1	
04	3418859	8	摇臂	LEVER,ROCKER	1	
03	3053478		摇臂	LEVER,ROCKER	1	
04	194037	5	摇臂凹头	SOCKET,ROCKER LEVER	1	
04	207226	4	衬套	BUSHING	1	
04	208084		铆钉	RIVTE	1	
04	3418858	3	摇臂	LEVER,ROCKER	1	
03	S 212	15	六角螺母	NUT,BEGULAR HEXAGON	3	
03	3176773		摇臂轴	SHAFT,ROCKER LEVER	1	
04	203933	11	碗型塞	PLUG,EXPANSION	1	
04	3176875	10	摇臂轴	SHAFT,ROCKER LEVER	1	
02	MP 5480		摇臂安装	LEVER,ROKER MTG	6	
03	205128	2	平垫圈	WASHER PLAIN	2	
03	205393	17	十二角螺栓	SCREW,TWELVE POINT CAP	1	
03	205394	12	十二角螺栓	SCREW,TWELVE POINT CAP	1	
02	MP 5479		摇臂室安装	HOUSING,ROCKER ARM MTG	6	
03	108602	13	六角螺栓	SCREW,HEXAGON HEAD C	5	
03	205128	2	平垫圈	WASHER PLAIN	6	
03	3630839	14	摇臂室衬垫	GASKET,RKR LEVER HOUSING	1	
03	S 125	1	六角螺栓	SCREW,HEXAGON HEAD CAP	1	

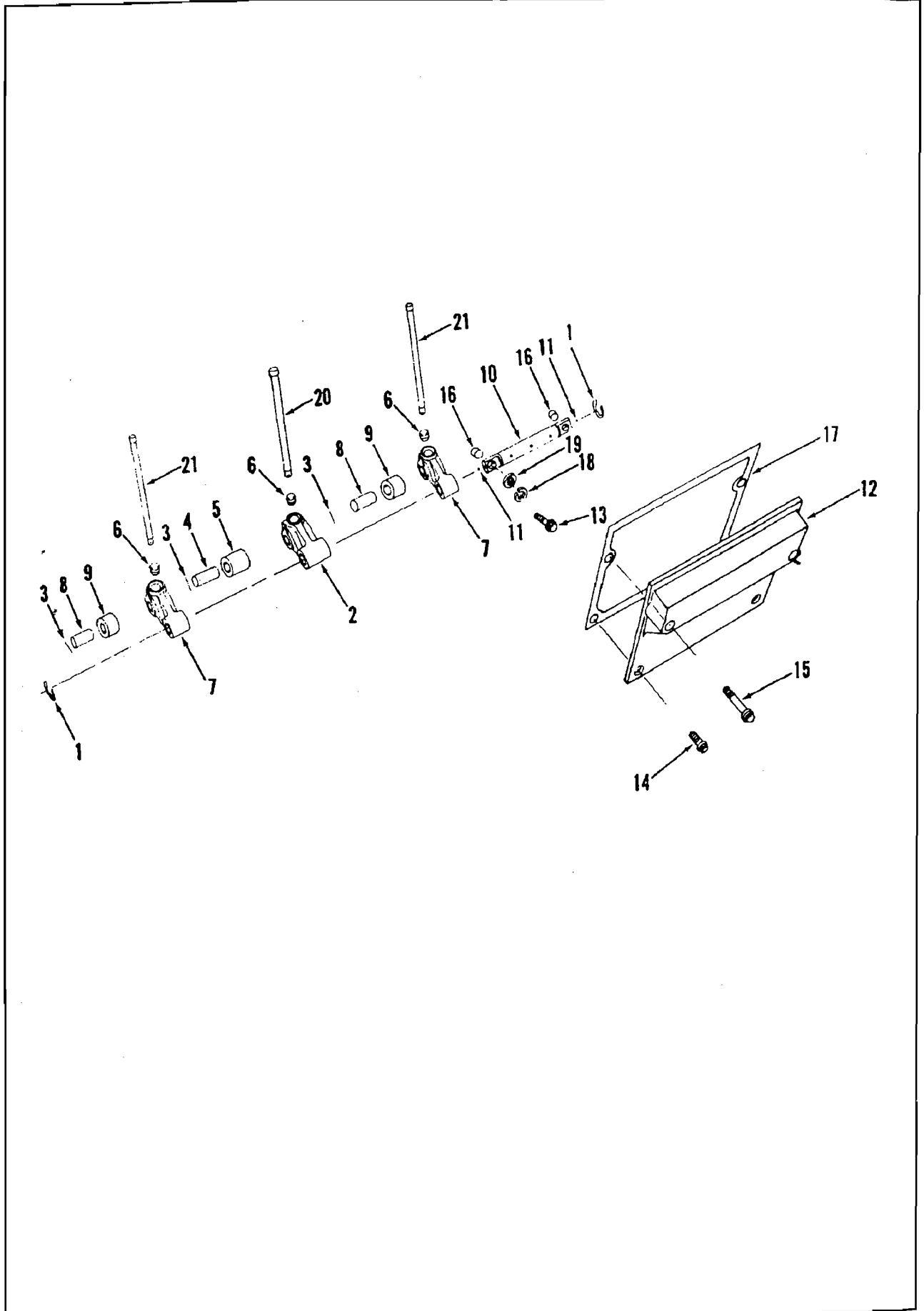

级别 LV	零件号 Part Number		图上标号 Ref No	零件名称 Part Name		数量 Req	备注 Remarks
				中文	英文		
02	AR10627	CE		凸轮轴从动件	FOLLOWER, CAMSHAFT	6	适用于:
03	205439		1	卡环	RING, RETAINING	2	KTA19-G2(M)
03	AR10626			轴和管塞	SHAFT & PLUG	1	/G3(M)
04	205227		11	碗形塞	PLUG, EXPANSION	2	
04	205301		10	凸轮从动件轴	SHAFT, CAM FOLLOWER	1	
03	3039163	B		凸轮从动件	LEVER, CAM FOLLOWER	1	
04	205068		4	喷油凸轮从动件滚轮销	PIN, CAM FOLLOWER	1	
04	205438			滚轮锁紧钢丝	LOCKWIRE, CAM ROL	1	
04	213559		6	凸轮轴从动件凹头	SOCKET CAM FOLLOW	1	
04	3016825		5	凸轮从动件滚轮	ROLLER, CAM FOLLOW	1	
04	3655377		2	喷油凸轮从动件分总成	LEVER, CAM FOLLOWER	1	
03	3039164	B		凸轮从动件	LEVER, CAM FOLLOWER	2	
04	205071		8	气门凸轮从动件滚轮销	PIN, CAM FOLLOWER	1	
04	205438		3	滚轮锁紧钢丝	LOCKWIRE, CAM ROL	1	
04	213559		6	凸轮轴从动件凹头	SOCKET CAM FOLLOW	1	
04	3016826		9	凸轮从动件滚轮	ROLLER, CAM FOLLOWER	1	
04	3655378		7	气门凸轮从动件分总成	LEVER, CAM FOLLOW	1	
02	MP 4987			凸轮从动件安装	FOLLOWER, CAMSHAFT	6	
03	127362		19	平垫圈	WASHER, PLAIN	2	
03	3002886		13	凸轮从动件螺栓	SCREW, CAMFOLLOWER	2	
03	3002993		16	定位环	DOWEL, RING	2	
03	S 604		18	弹簧垫圈	WASHER, LOCK	2	
02	3628755		12	凸轮从动件盖	COVER CAMSHAFT	4	
02	MP 5297			凸轮从动件盖安装	COVER, CAM FOLLOWER	6	
03	S 602		19	平垫圈	WASHER, PLAIN	4	
03	3010596		14	带垫圈螺栓	SCREW, CAPTIVE WAS	2	
03	3040721		17	凸轮从动件衬垫	GASKET, CAM FOL HOUSING	1	
03	S 126		15	六角螺栓	SCREW, HEXAGON HEAD CAP	2	
03	S 604		18	弹簧垫圈	WASHER, LOCK	2	
02	205492		21	推杆	ROD, PUSH	12	
02	3017961		20	喷油推杆	ROD, PUSH	6	

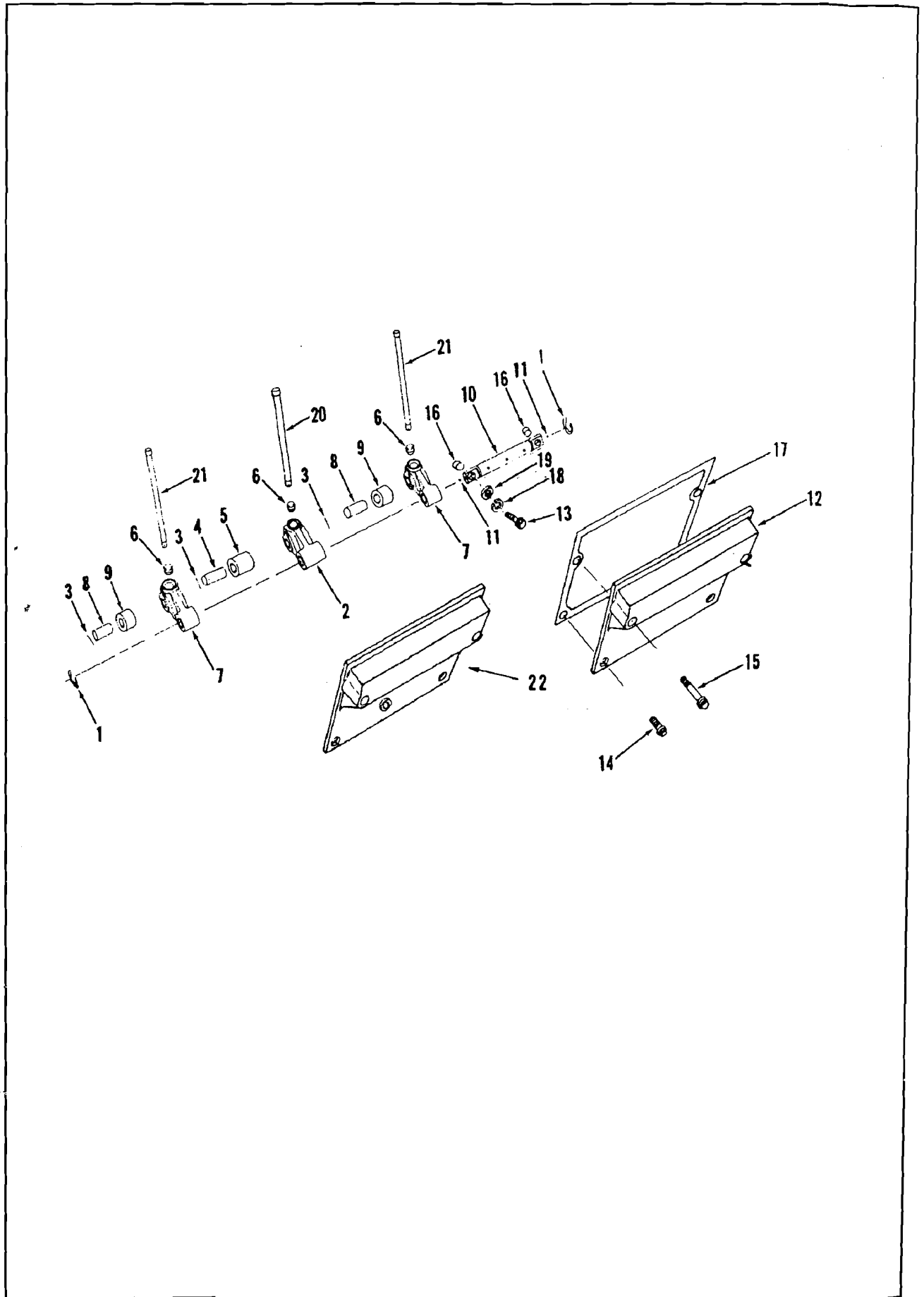

凸轮轴从动件 Camshaft Follower

级别 LV	零件号 Part Number	图上标号 Ref No	零件名称 Part Name		数量 Req	备注 Remarks
			中文	英文		
02	3078180		凸轮轴从动件	FOLLOWER, CAMSHAFT	6	适用于: KTA19-G4(M)
03	205439	1	卡环	RING, RETAINING	2	
03	3039164		凸轮从动件	LEVER, CAM FOLLOWER	2	
04	4009248	8	气门凸轮从动件滚轮销	PIN, CAM FOLLOWER ROLLER	1	
04	205438	3	滚轮锁紧钢丝	LOCKWIRE, TPT ROLLER PIN	1	
04	213559	6	凸轮轴从动件凹头	SOCKET, CAM FOLLOWER	1	
04	3016826	9	凸轮从动件滚轮	ROLLER, CAM FOLLOWER	1	
04	205069	7	气门凸轮从动件分总成	LEVER, CAM FOLLOW	1	
03	3078218		轴和管塞	SHAFT, CAM FOLLOWER	1	
04	205227	11	碗形塞	PLUG, EXPANSION	2	
04	3077538	10	凸轮从动件轴	SHAFT, CAM FOLLOWER	1	
03	3081413		凸轮随动件	LEVER, CAM FOLLOWER	1	
04	205438	3	滚轮锁紧钢丝	LOCKWIRE, TPT ROLLER PIN	1	
04	213559	6	凸轮轴从动件凹头	SOCKET, CAM FOLLOWER	1	
04	3062141	5	凸轮从动件滚轮	ROLLER, CAM FOLLOWER	1	
04	3081411	2	喷油凸轮从动件分总成	LEVER, CAM FOLLOWER	1	
04	3081412	4	喷油凸轮从动件滚轮销	PIN, CAM FOLLOWER	1	
02	MP 4987		凸轮从动件安装	FOLLOWER, CAMSHAFT	6	
03	127362	19	平垫圈	WASHER, PLAIN	2	
03	3002886	13	凸轮从动件螺栓	SCREW, CAMFOLLOWER	2	
03	3002993	16	定位环	DOWEL, RING	2	
03	S 604	18	弹簧垫圈	WASHER, LOCK	2	
02	3628755	12	凸轮从动件盖	COVER CAMSHAFT	3	
02	3628756	22	凸轮从动件盖	COVER CAMSHAFT	1	
02	MP 5297		凸轮从动件盖安装	COVER, CAM FOLLOWER	5	
03	S 602	19	平垫圈	WASHER, PLAIN	4	
03	3010596	14	带垫圈螺栓	SCREW, CAPTIVE WAS	2	
03	3040721	17	凸轮从动件衬垫	GASKET, CAM FOL HOUSING	1	
03	S 126	15	六角螺栓	SCREW, HEXAGON HEAD CAP	2	
03	S 604	18	弹簧垫圈	WASHER, LOCK	2	
02	3077983		凸轮轴从动件盖安装	COVER, CAM FOLLOWER	1	
03	3040721	17	凸轮从动件衬垫	GASKET, CAM FOL HOUSING	1	
03	3040838	23	带垫螺栓	SCREW, CAPTIVE WASHER CAP	2	
03	3060567	24	带垫螺栓	SCREW, CAPTIVE WASHER CAP	2	
03	3088375	25	支架	BRACKET, VALVE	1	
02	205492	21	推杆	ROD, PUSH	12	
02	3017961	20	喷油推杆	ROD, PUSH	6	

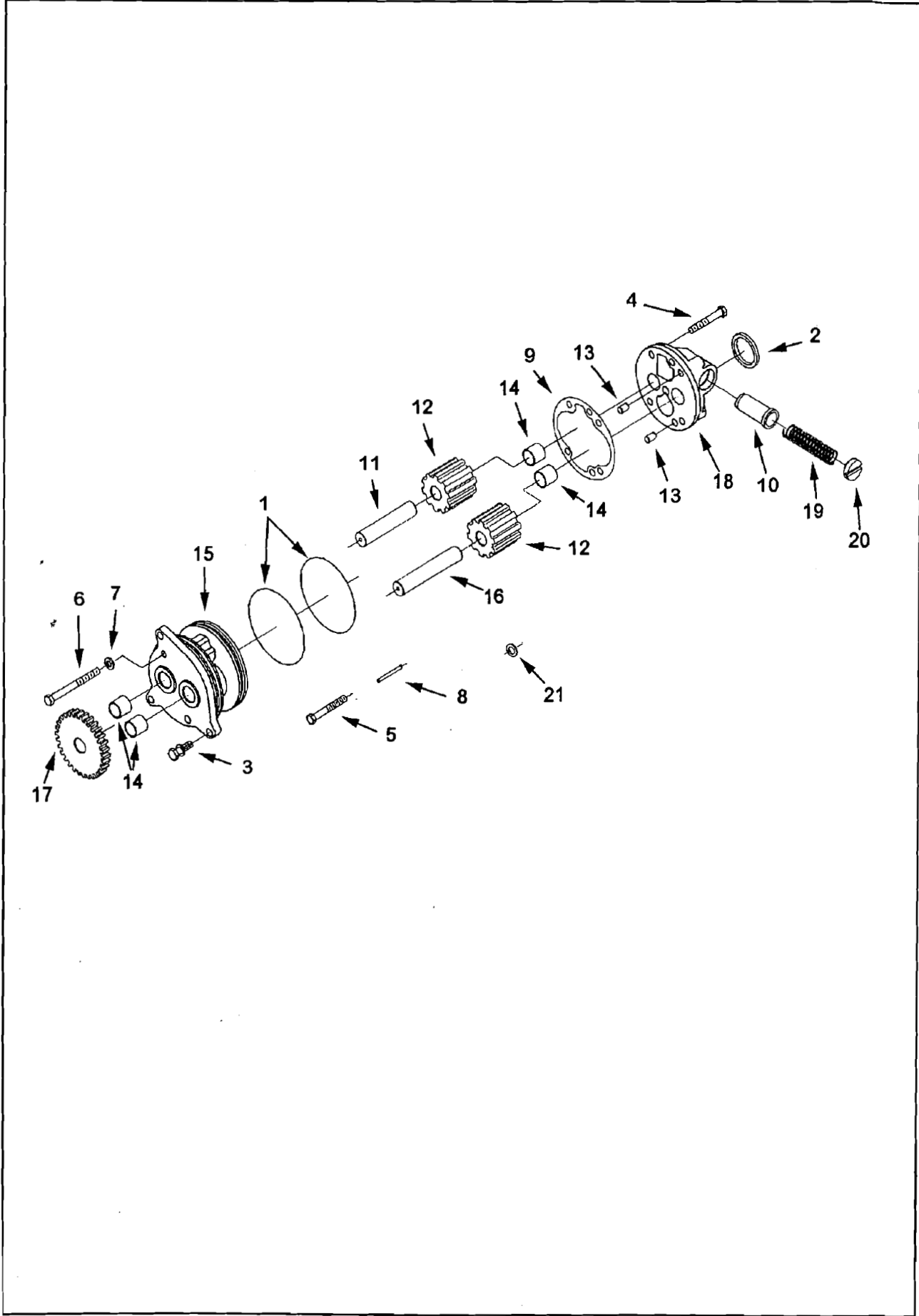

级别 LV	零件号 Part Number	图上标号 Ref No	零件名称 Part Name		数量 Req	备注 Remarks
			中文	英文		
02	3047549		机油泵总成	PUMP, LUBRICATING OIL	1	总成装配
03	148554	8	定位销	DOWEL	1	
03	205061	9	机油泵垫片	GASKET, LUB OIL PUMP	1	
03	205080	10	压力调节器柱塞	PLUNGER, PRS REGULATOR	1	
03	205202		齿轮与轴	GEAR & SHAFT	1	
04	3049543	12	机油泵齿轮	GEAR, LUB OIL PU MP	1	
04	205052	11	被动轮轴	SHAFT, IDLER	1	
03	207279		机油泵	PUMP, LUBRICATING OIL	1	
04	70760	13	定位销	DOWEL	1	
04	205057		机油泵体总成	BODY, LUBRICATING OIL PUMP	1	
05	69521	14	衬套	BUSHING	2	
05	205049	15	机油泵体	BODY, LUBRICATING	1	
04	205077		齿轮与轴	GEAR & SHAFT	1	
05	3049543	12	机油泵齿轮	GEAR, LUB OIL PU MP	1	
05	205065	16	机油泵驱动轴	SHAFT, LUB PUMP D	1	
04	207252	17	机油泵驱动齿轮	GEAR, LUBRICATING OIL PUMP	1	
03	3047548		机油泵盖总成	COVER, LUB OIL PUMP	1	
04	69521	14	衬套	BUSHING	2	
04	3009955	18	机油泵盖	COVER, LUB OIL PUMP	1	
03	3062415	19	压力调节器弹簧	SPRING, COMPRESSION	1	
03	3200934	20	挡塞	PLUG, RETAINER	1	
03	3088291	21	平垫圈	WASHER, PLAIN	1	
03	S 126	4	六角螺栓	SCREW, HEXAGON HEAD CAP	2	
03	S 141	5	螺栓	SCREW, HEXAGON HEAD CAP	1	
03	S 103	6	六角螺栓	SCREW, HEXAGON HEAD CAP	1	
03	S 604	7	弹簧垫圈	WASHER, LOCK	4	
02	MP 4973		机油泵安装件	PUMP, LUB OIL MTG	1	
03	205898	1	O型密封圈	SEAL, ORING	2	
03	207135	2	矩形密封圈	SEAL, RECTANGULAR	1	
03	3010596	3	带垫圈螺栓	SCREW, HEXAGON HEAD CAP	3	

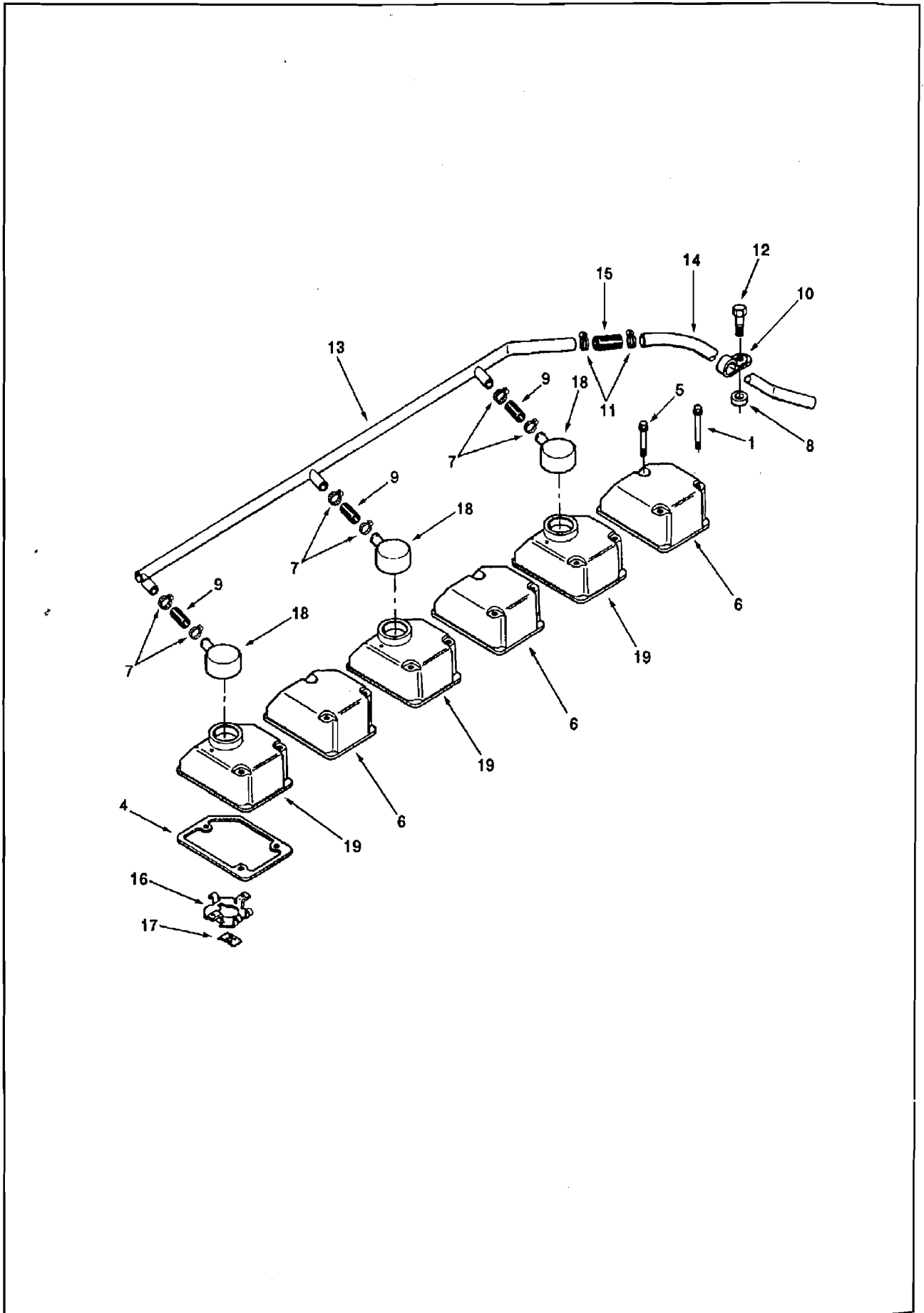

表一11

曲轴箱通风器 Breather Location

BR 4027

级别 LV	零件号 Part Number	图上标号 Ref No	零件名称 Part Name		数量 Req	备注 Remarks
			中文	英文		
02	3047710		摇臂室盖	COVER,ROCKER ARM HSG	3	
03	219065	16	通气孔挡板	BAF-FLE.BREATHER	1	
03	3000528	17	矩形弹性螺母	NUT,SPRING	2	
03	3046853		摇臂室盖	COVER,ROCKER LEVER	1	
04	3008595	18	曲轴箱通风器	BREATHER,CRANKCASE	1	
04	3010396	19	摇臂室盖	COLER,ROCKER LEVER	1	
02	3010388	6	摇臂室盖	COVER,ROCKER LEVER	3	
02	3010249		摇臂室盖安装	COVER VALVE MTG	6	
03	3044413	5	带垫螺栓	SCREW,CAPTIVE WASHER	1	
03	3629140	4	摇臂室盖衬垫	GASKET,ROCKER LEVER COVE	1	
03	S 169	A 1	六角螺栓	SCREW,HEXAGON HEAD CAP	2	
03	S 602		平垫圈	WASHER,PLAIN	2	
03	S 604		弹簧垫圈	WASHER,LOCK	2	
02	3047205		通风管	TUBE,BREATHER	1	
03	43828	7	抱箍	CLAMP,HOSE	6	
03	63385	8	隔套	SPACER,WATER CONNECTION	2	
03	64775	9	软管	HOSE,PLAIN	3	
03	67949	10	夹子	CLIP	2	
03	3012475	12	带垫螺栓	SCREW,CAPTIVE WAS	2	
03	43828	A 11	抱箍	CLAMP,HOSE	2	
03	3046834	13	通风管	TUBE,BREATHER	1	
03	3046838	14	通风管	TUBE,BREATHER	1	
03	3200316	15	普通软管	HOSE,PLAIN	1	

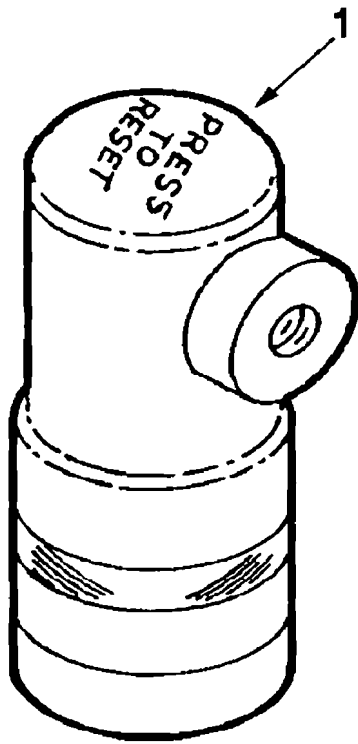

级别 LV	零件号 Part Number	图上标号 Ref No	零件名称 Part Name		数量 Req	备注 Remarks
			中文	英文		
02	178957	1	空气阻力指示器	INDICATOR, RESTRICTION	1	

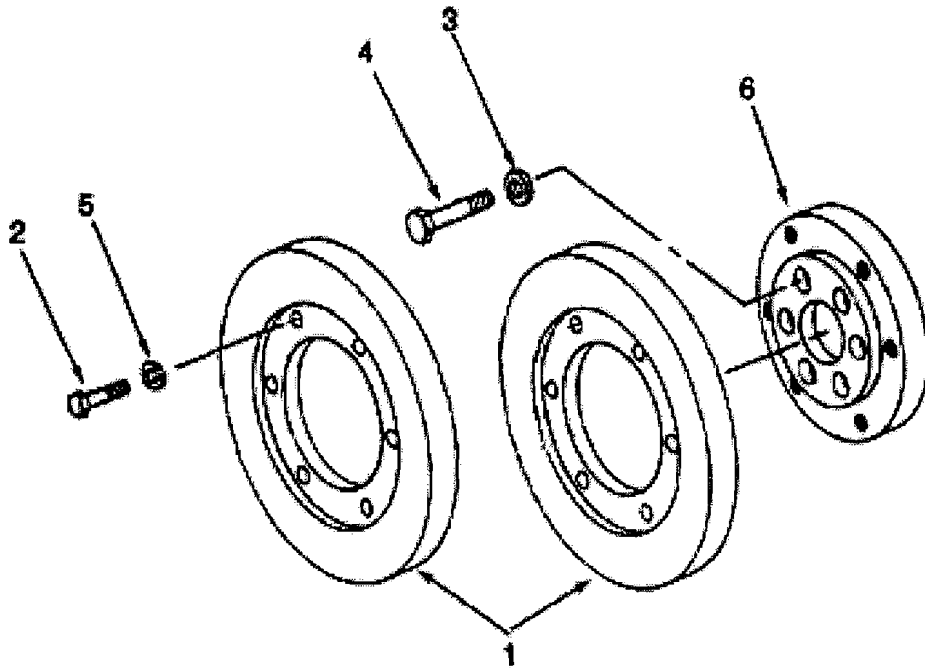

注
rks

级别 LV	零件号 Part Number	图上标号 Ref No	零件名称 Part Name		数量 Req	备注 Remarks
			中文	英文		
02	217322	1	硅油减振器	DAMPER, VIBRATION	2	
02	3203694	6	曲轴皮带轮	PULLEY, CRANKSHAFT	1	
02	MP45209		减振器安装	DAMPER, VIBRATION MTG	1	
03	205059	3	平垫圈	WASHER, CYLINDER	6	
03	206881	4	十二角螺栓	SCREW, TWELVE POINT	6	
03	210028	2	十二角螺栓	SCREW, TWELVE POINT	6	
03	S 608	5	弹簧垫圈	WASHER, LOCK	6	

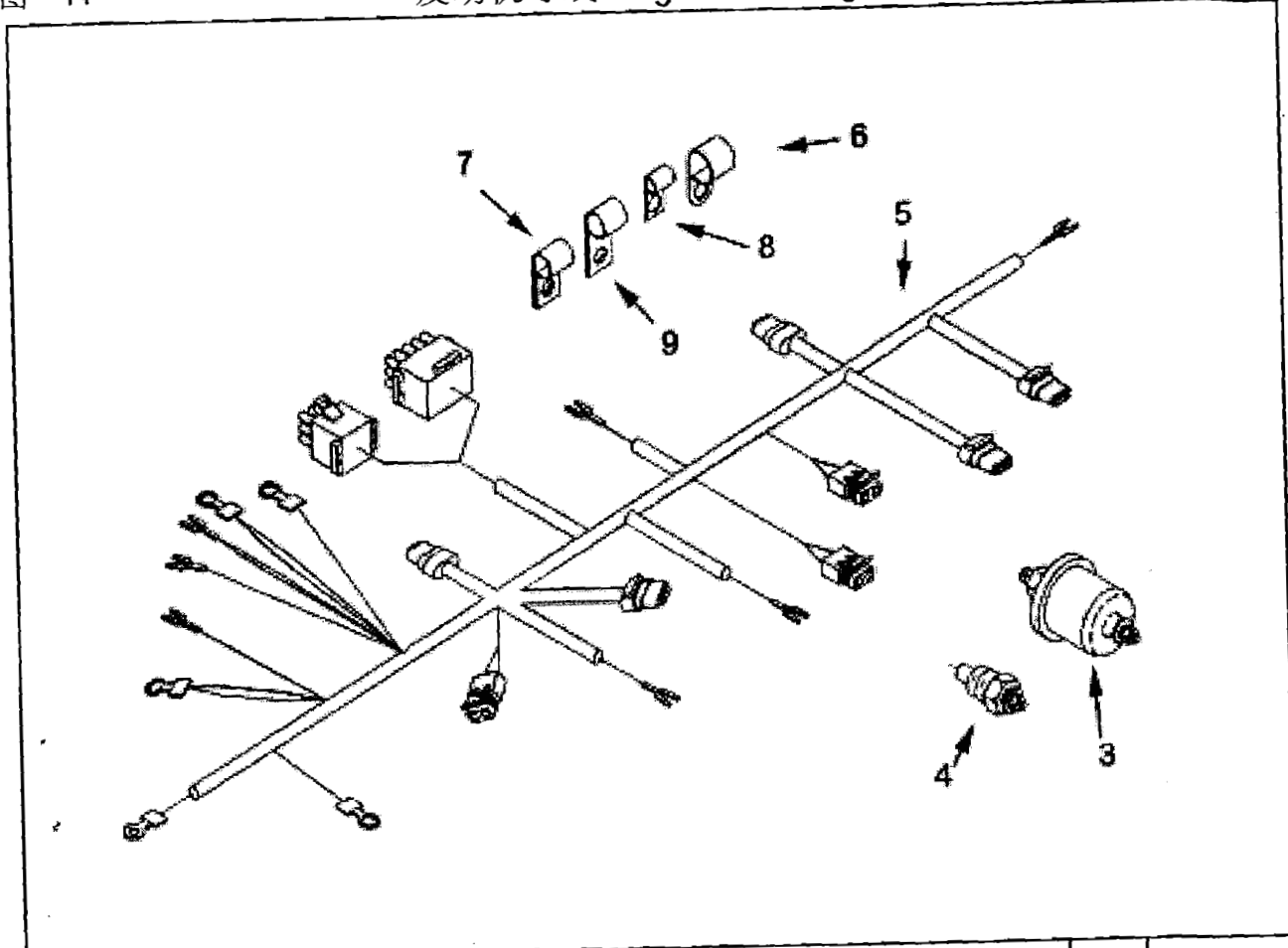

级别 LV	零件号 Part Number	图上标号 Ref No	零件名称 Part Name		数量 Req	备注 Remarks
			中文	英文		
02	3015237	3	油压传感器	TRANSDUCER	1	
02	3015238	4	温度传感器	TRANSDUCER	2	
02	3165394	5	导线	HARNESS, WIRING	1	
02	3064824		导线安装	MTG, WRIE HARNSS	1	
03	68425	6	夹子	CLIP	1	
03	108722	8	夹箍	CLIP	5	
03	180372	9	夹子	CLIP	4	
02	201351	7	卡箍	CLIP	5	

图-15

油压报警开关 Low Oil Pressure Switch

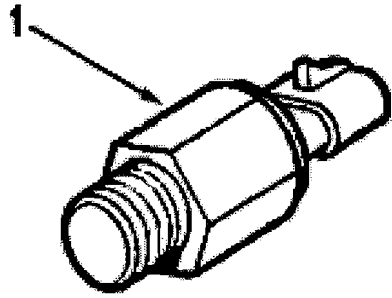

注
S

级别 LV	零件号 Part Number	图上标号 Ref No	零件名称 Part Name		数量 Req	备注 Remarks
			中文	英文		
02	3056344	1	油压报警开关	SWITCH, PRESSURE	1	

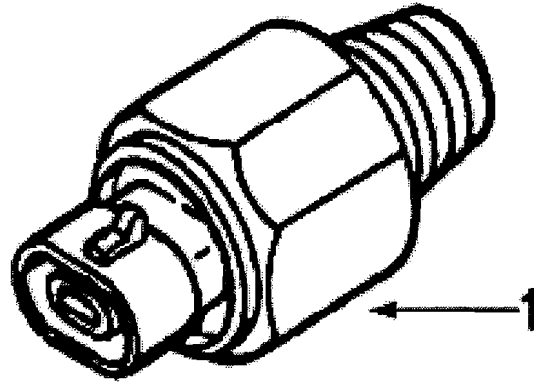

级别 LV	零件号 Part Number	图上标号 Ref No	零件名称 Part Name		数量 Req	备注 Remarks
			中文	英文		
02	3056353	1	水温报警开关	SWITCH, TEMPERATURE	1	

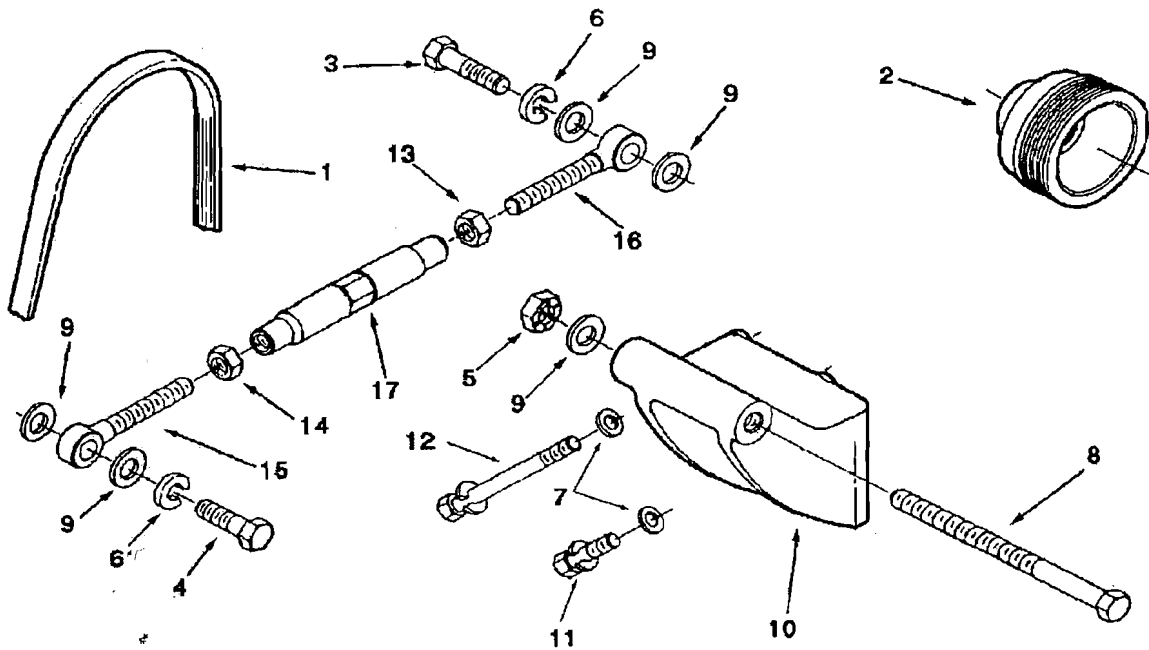

级别 LV	零件号 Part Number	图上标号 Ref No	零件名称 Part Name		数量 Req	备注 Remarks
			中文	英文		
02	206996	1	多槽皮带	BELT, VRIBBED	1	
02	3002323	2	发电机皮带轮	PULLEY, ALTERNATOR	1	
02	3200770		发电机安装	ALTERNATOR.MTG	1	
03	70897	5	锁紧螺母	NUT, LOCK	1	
03	111445	6	弹簧垫圈	LCK, WSHR	2	
03	127362	7	平垫圈	WASHER, PLAIN	4	
03	158829	8	六角螺栓	SCREW, HEXAGONHEAD	1	
03	203310	9	平垫圈	WASHER, PLAIN	5	
03	3006774	10	发电机支架	BRACKET, ALTERNATOR	1	
03	3010596	11	带垫圈螺栓	SCREW, CAPTIVE WAS	2	
03	3010597	12	带垫螺栓	SCREW, CAPTIVE WAS	2	
03	3419317	17	调节杆	LINK, ADJUSTING	1	
03	S 106	3	六角螺栓	SCREW, HEXAGON HEAD	1	
03	S 113	4	六角螺栓	SCREW, HEXAGON HEAD	1	

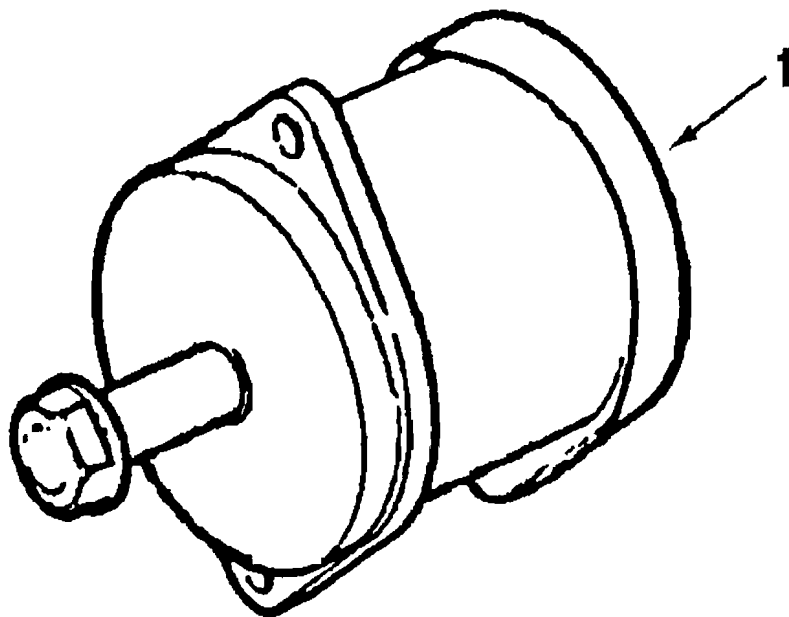

级别 LV	零件号 Part Number	图上标号 Ref No	零件名称 Part Name		数量 Req	备注 Remarks
			中文	英文		
02	3016627	1	交流发电机	ALTERNATOR	1	

记 录

注
rks



表-19

齿轮室盖 Cover, Gear Housing

EM 4106

级别 LV	零件号 Part Number	图上标号 Ref No	零件名称 Part Name		数量 Req	备注 Remarks
			中文	英文		
02	3034776		齿轮室盖及盘车机构	COVER, GEAR	1	
03	3009620	9	发动机盘车弹簧	SPRING, ENGINE BAR	1	
03	3013786	10	管塞	PLUG, PIPE	2	
03	3015525	11	挡圈	RING, RETAINING	1	
03	3018914		盘车轴套	GUIDE, BARRING SHAFT	1	
	3018909	12	衬套	BUSHING	1	
	3018910	13	止推轴承	BEARING, THRUST	1	
	3018911	14	圆销	PIN, ROLL	1	
	3019154	15	盘车轴	GUIDE, BARRING SHAFT	1	
03	3019152	16	发动机盘车齿轮	GEAR, ENGING BARRING	1	
03	3019153	17	盘车轴	SHAFT, BARRING	1	
03	3025460	18	管塞	PLUG, PIPE	6	
03	3034777		齿轮室盖	COVER, GEAR	1	
04	132770	21	衬套	BUSHING	2	
04	205133	22	衬套	BUSHING	1	
04	3021194	25	齿轮室盖	COVER, GEAR	1	
04	3016787	23	油封	SEAL, OIL	1	
04	3016791	24	油封	SEAL, OIL	1	
04	3628895	26	油封	SEAL, OIL	1	
03	3201125	27	O型密封圈	SEAL ORING	1	
02	3044522		正时齿轮室板	PLATE, GEAR COVER	1	
03	206217	28	双头螺栓	STUD	1	
03	206218	29	双头螺栓	STUD	1	
03	3019961	30	堵塞螺母	NUT, PLUG	2	
03	3044521	31	正时齿轮室板	PLATE, GEAR COVER	1	
02	3016717		正时齿轮室板安装	MTG, GEAR COVER	1	
03	70645	4	主定位销	DOWEL PIN	1	
03	102957	5	定位销	DOWEL, DIAMOND	1	
03	3014766	6	带垫螺栓	SCREW, CAPTIVE WASHER CAP	12	
03	3410141	7	衬垫	GASKET, COVER PIAT	1	
02	AR10702		发动机前支架安装	SUPPURT, FRONT EN	1	
03	206343	3	发动机前支架	SUPPORT, FRONT ENGING	1	
03	S 173	A 1	六角螺栓	SCREW, HEXAGON HEAD	6	
03	S 603	2	弹簧垫圈	WASHER, LOCK	6	
02	3200642	33	夹板	PLATIE CLAMPING		

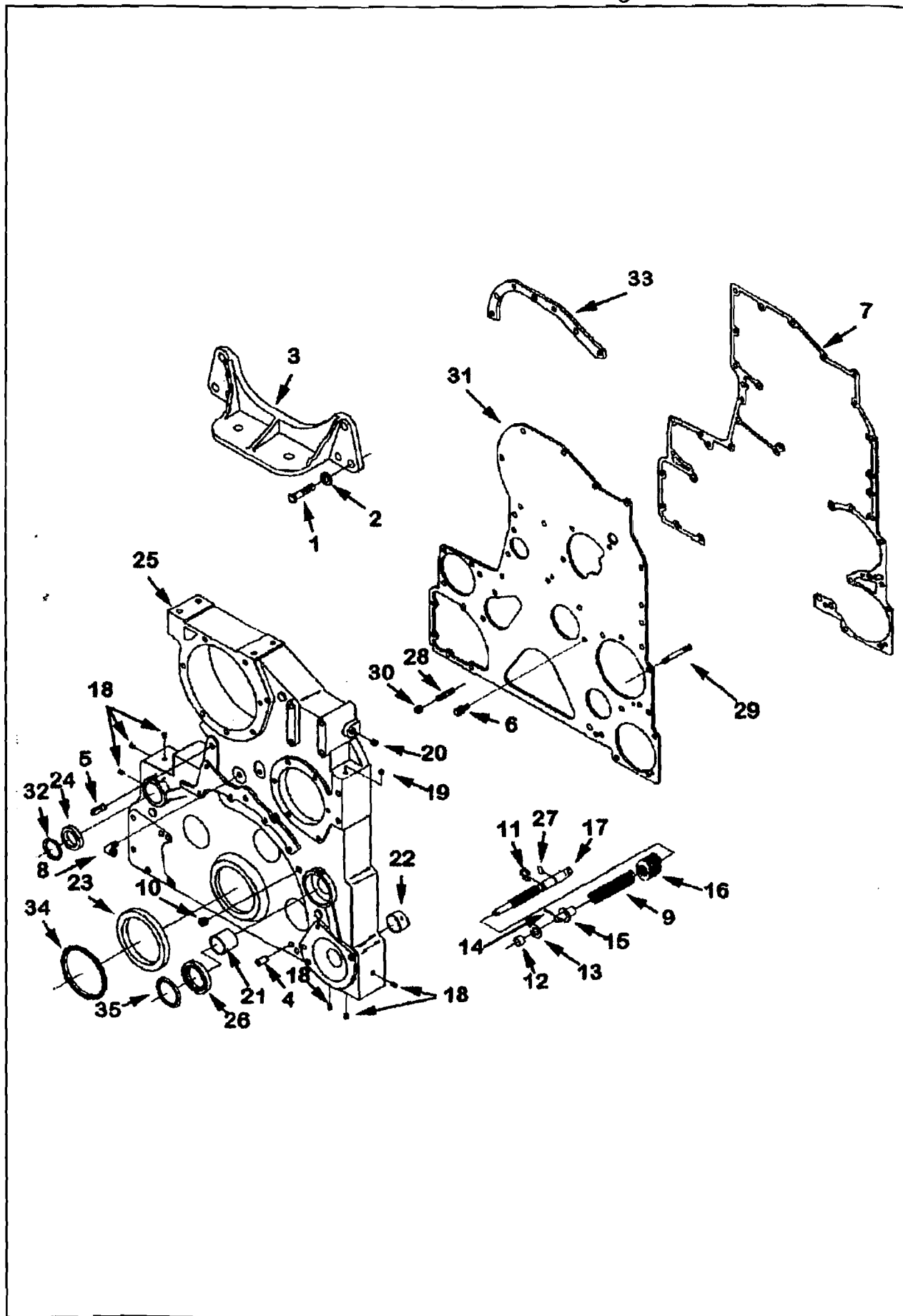

表-20

齿轮室盖安装 Mtg, Gear Cover

EM 4714

级别 LV	零件号		图上标号 Ref No	零件名称 Part Name		数量 Req	备注 Remarks
	Part Number			中文	英文		
02	3062488			齿轮室盖安装	COVER, GEARMOUNT I	1	
03	205375		3	十二角螺栓	SCREW, TWELVE POINT CAP	1	
03	3010595		4	带垫圈螺栓	SCREW, CAPTIVE WAS	3	
03	3012476		5	带垫螺栓	SCREW, CAPTIVE WAS	1	
03	3042890		6	六角螺栓	SCREW, HEXAGON HEAD CAP	11	
03	3074690		7	齿轮室盖衬垫	GASKET, GEAR COVER	1	
03	3201128		8	六角螺母	NUT, REGULAR HEXG	4	
03	S 199	B	1	六角螺栓	SCREW, HEXAGON HEAD CAP	7	
03	S 604		2	弹簧垫圈	WASHER, LOCK	12	

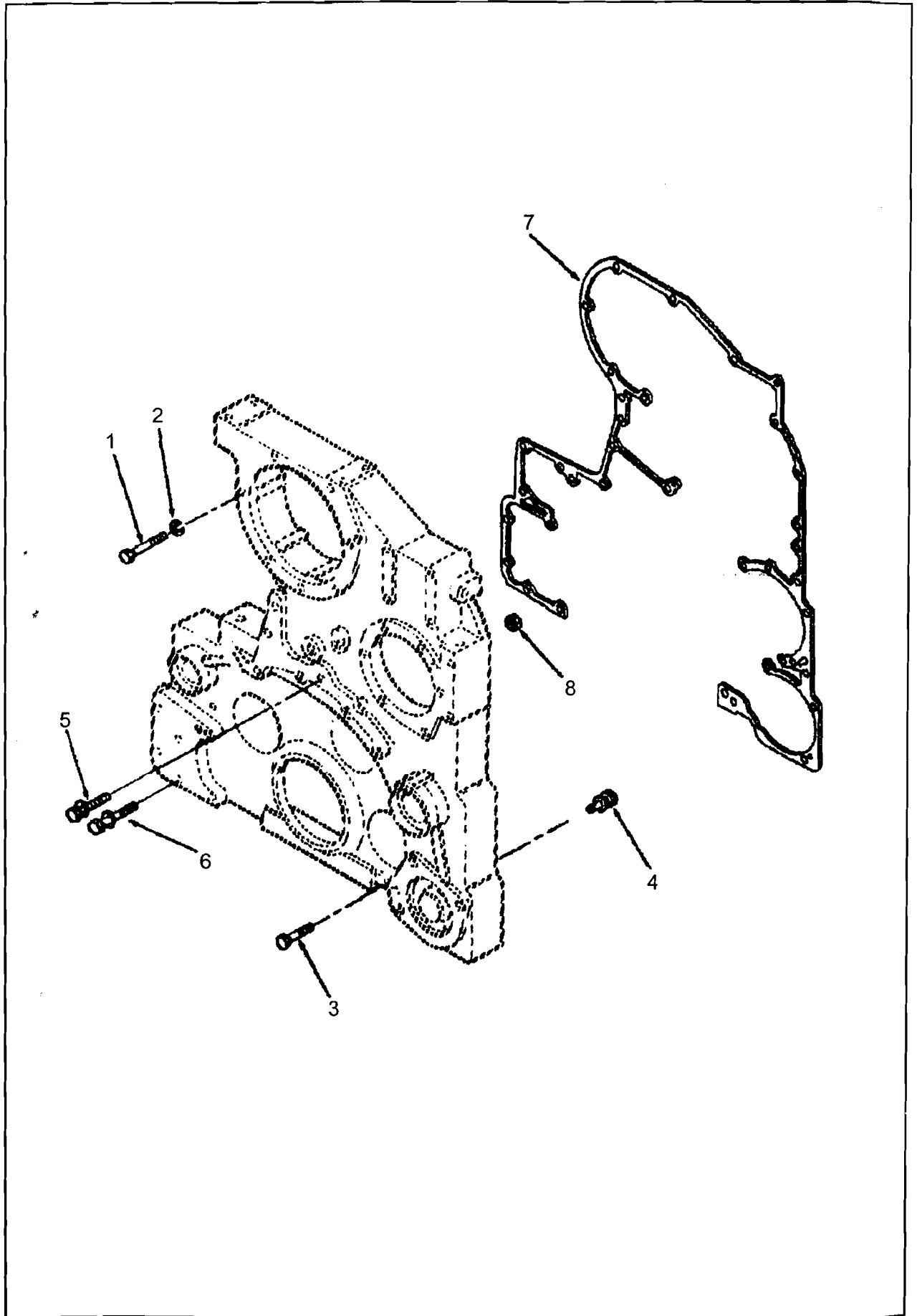

表-21

仪表箱 Instrument Panel

EP 408

级别 LV	零件号 Part Number	图上标号 Ref No	零件名称 Part Name		数量 Req	备注 Remarks
			中文	英文		
02	3037221	12	仪表板支架	BRACKET, INSTRUMENT PANEL	1	
02	3039974		隔振体	ISOLATOR, ENCLOSURE	1	
03	3033800	1	平垫圈	WASHER, PLAIN	8	
03	3035083	2	减振垫	ISOLATOR, VIBRATION	8	
03	3035084	3	减振垫	ISOLATOR, VIBRATION	8	
03	3165937	18	六角螺母	NUT, REGULAR HEXG	2	
03	3175239	4	锁紧螺母	NUT, LOCK	7	
02	4061529		仪表箱支架	BRACKET, ENCLOSURE	1	
03	3034824	6	安装隔套	SPACER, MOUNTING	1	
03	4061024	7	仪表板支架	BRACKET, INSTRUMENT PANEL	1	
03	3175576	8	六角螺栓	SCREW, HEXAGON HEAD	3	
03	S 604	5	弹簧垫圈	WASHER, LOCK	3	
02	4061530		仪表板支架	BRACE, ENCLOSURE LOWER	1	
03	4061025	11	仪表板支架	BRACE, ENCLOSURE PANEL	1	
03	S 106 C	9	六角螺栓	SCREW, HEXAGON HEAD	2	
03	S 604	10	弹簧垫圈	WASHER, LOCK	2	
02	3056413		仪表箱	ENCLOSURE	1	
03	3035132	13	导线	HARNES, WIRING	1	
03	3053010	14	仪表箱	ENCLOSURE	1	
03	3056393		线路板及安装	BOARD, ENGINE CIRCUIT	1	
04	70646	15	锁紧螺母	NUT, LOCK	4	
04	128006	16	平垫圈	WASHER, PLAIN	4	
04	3053065	17	线路板	BOARD, CIRCUIT	1	

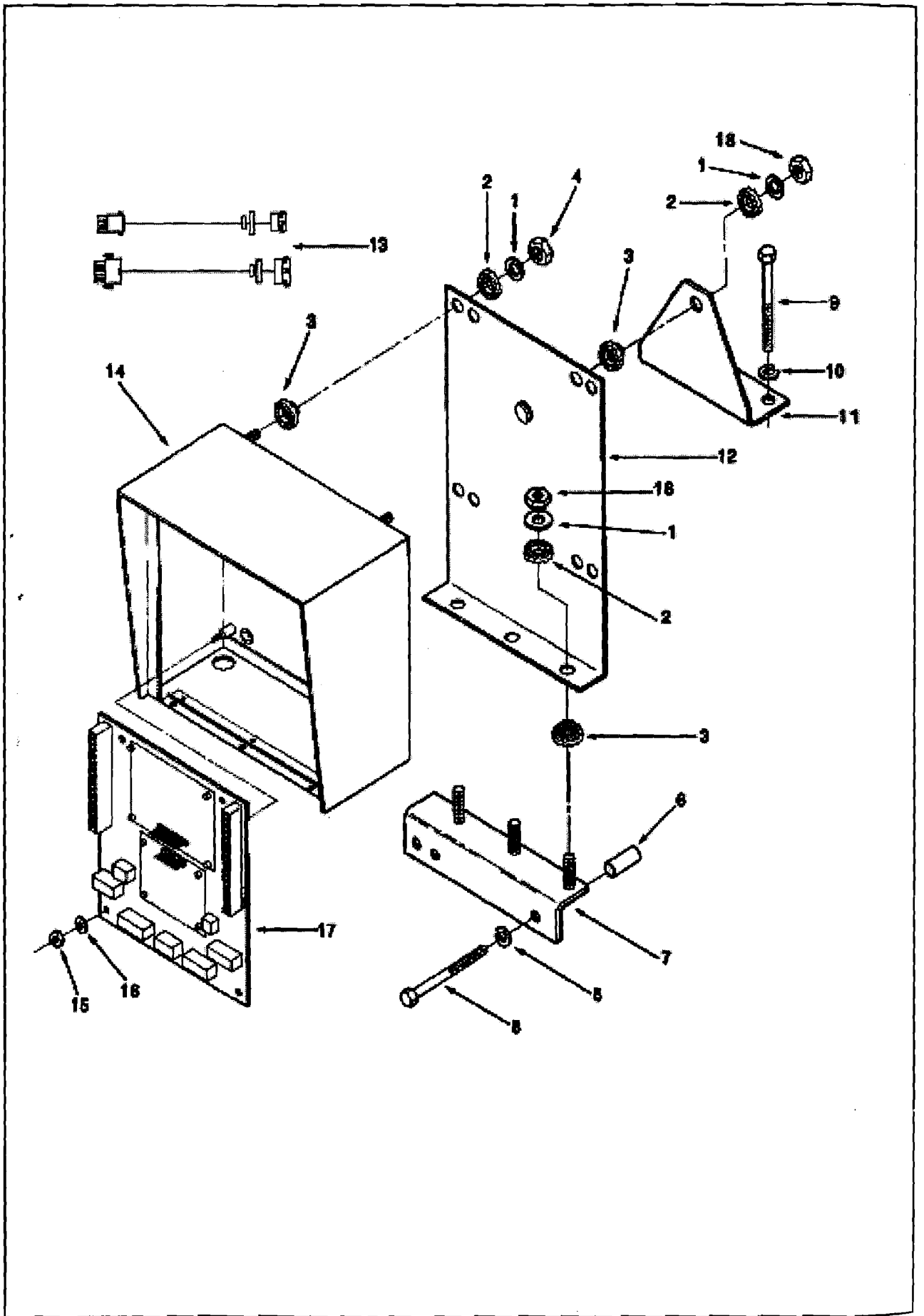
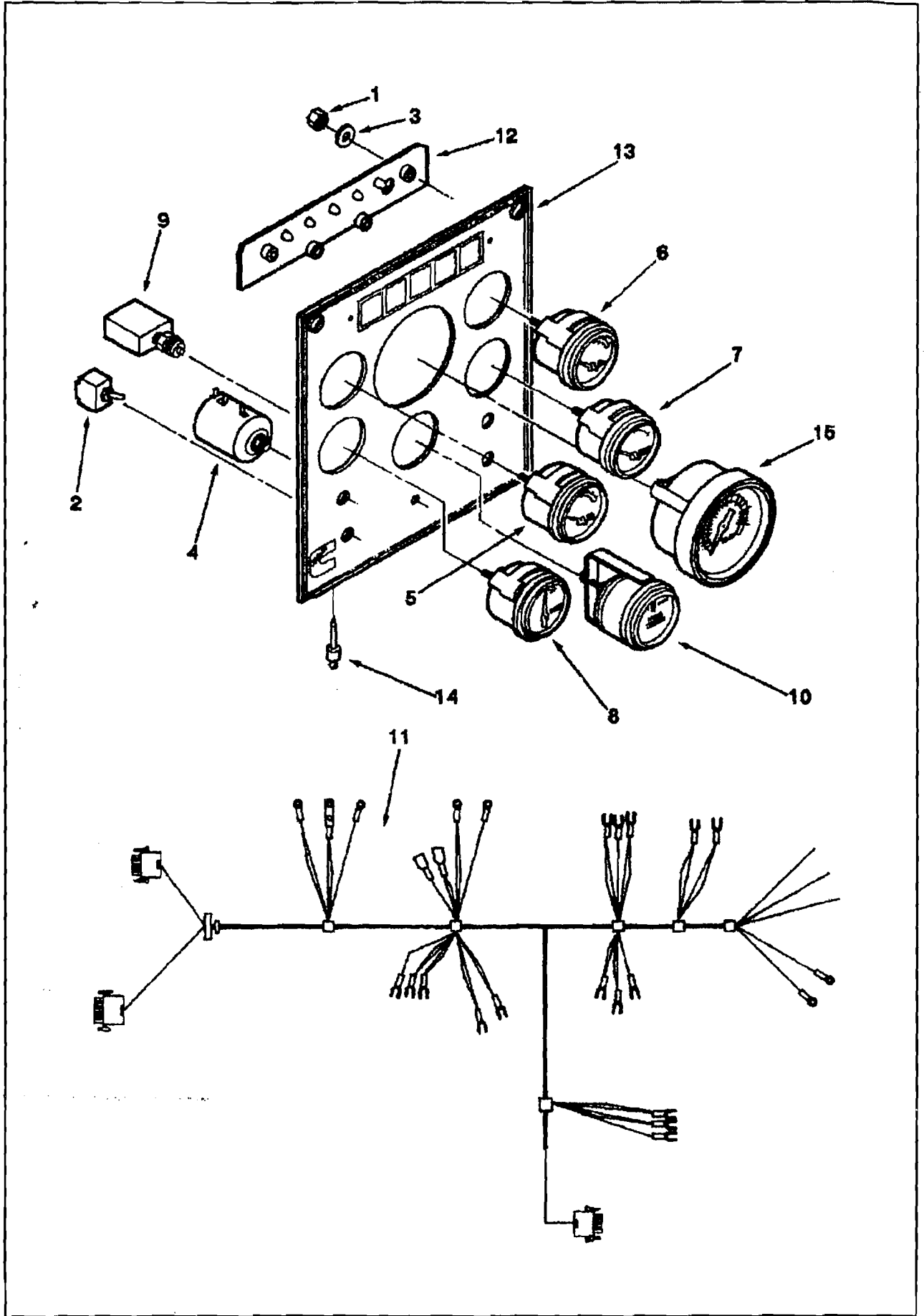

表一22

仪表板 Instrument Panel

EP 8030

级别 LV	零件号 Part Number	图上标号 Ref No	零件名称 Part Name		数量 Req	备注 Remarks
			中文	英文		
02	3062654		仪表板	PANEL, ENGINE INSTRUMENT	1	
03	70646	1	锁紧螺母	NUT, LOCK	4	
03	104215	2	跳动式开关	SWITCH, TOGGLE	1	
03	128006	3	平垫圈	WASHER, PLAIN	4	
03	3015105	4	电位器	POTENTIOMETE	1	
03	3015232	5	压力表	GAUGE, PRESSURE	1	
03	3015233	6	温度表	GAUGE, TEMPERATURE	1	
03	3015234	7	温度表	GAUGE, TEMPERATURE	1	
03	3015235	8	电压表	VOLTMETER	1	
03	3031734	15	转速表	TACHOMETER	1	
03	3034953	9	断路器	BREAKER, CIRCUIT	1	
03	3035766	10	小时计	HOURLMETER	1	
03	3053044	11	导线	HARNES, WIRING	1	
03	3053060	12	线路板	BOARD, CIRCUIT	1	
03	3053077	13	仪表板	PANEL, INSTRUMENT	1	
03	3056060	14	铆钉	RIVET	3	

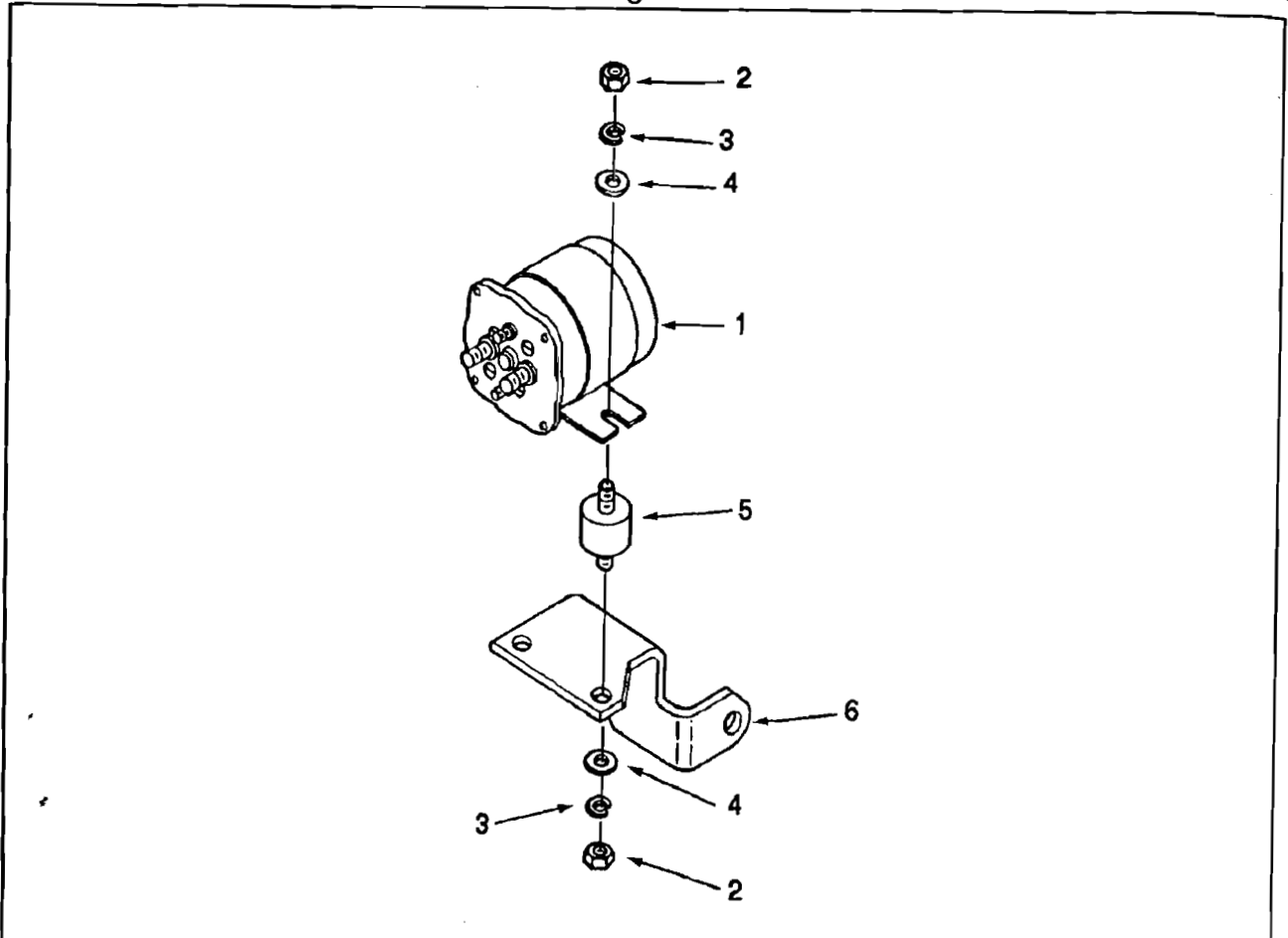

级别 LV	零件号 Part Number	图上标号 Ref No	零件名称 Part Name		数量 Req	备注 Remarks
			中文	英文		
02	3050692	1	电磁开关	SWITCH, MAGNETIC	1	
02	3052529		磁力开关安装件	SWITCH, MAGNETIC	1	
03	S 224	2	六角厚螺母	NUT, HEAVY HEXAGON JAM	4	
03	S 600	3	弹簧垫圈	WASHER, LOCK	4	
03	S 631	4	平垫圈	WASHER, PLAIN	4	
03	204493	5	减振垫	SCREW, HEXAGON HEAD	2	
03	3062483	6	安装支架	BRACKET, MAGNETIC	1	

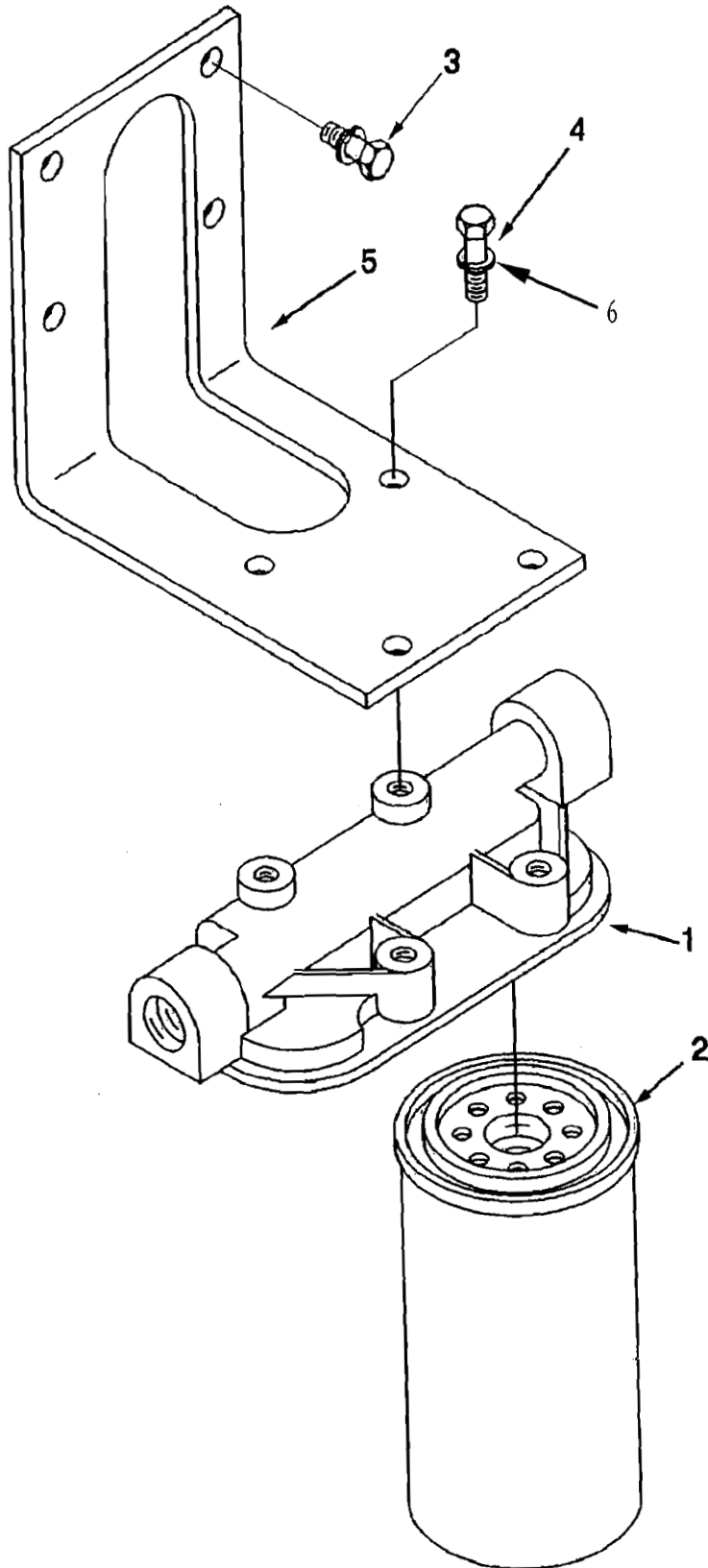

表—24

燃油滤清器 Fuel Filter

FF 4013

级别 LV	零件号 Part Number	图上标号 Ref No	零件名称 Part Name		数量 Req	备注 Remarks
			中文	英文		
02	AR13274		燃油滤清器	FILTER, FUEL	1	
03	3315843	2	燃油滤清器	FILTER, FULE	2	
03	3418763	1	燃油座	HEAD, FUEL FILTER	1	
02	MP45194		燃油滤清器支架安装	BRACKET, FUEL FILTER MTG	1	
03	3201394	5	滤清器支架	BRACKET, FILTER	1	
03	S 103 D	4	六角螺栓	SCREW, HEXAGON HEAD CAP	4	
03	S 120	3	六角螺栓	SCREW, HEXAGON HEAD CAP	4	
03	S 604	6	弹簧垫圈	WASHER, LOCK	8	

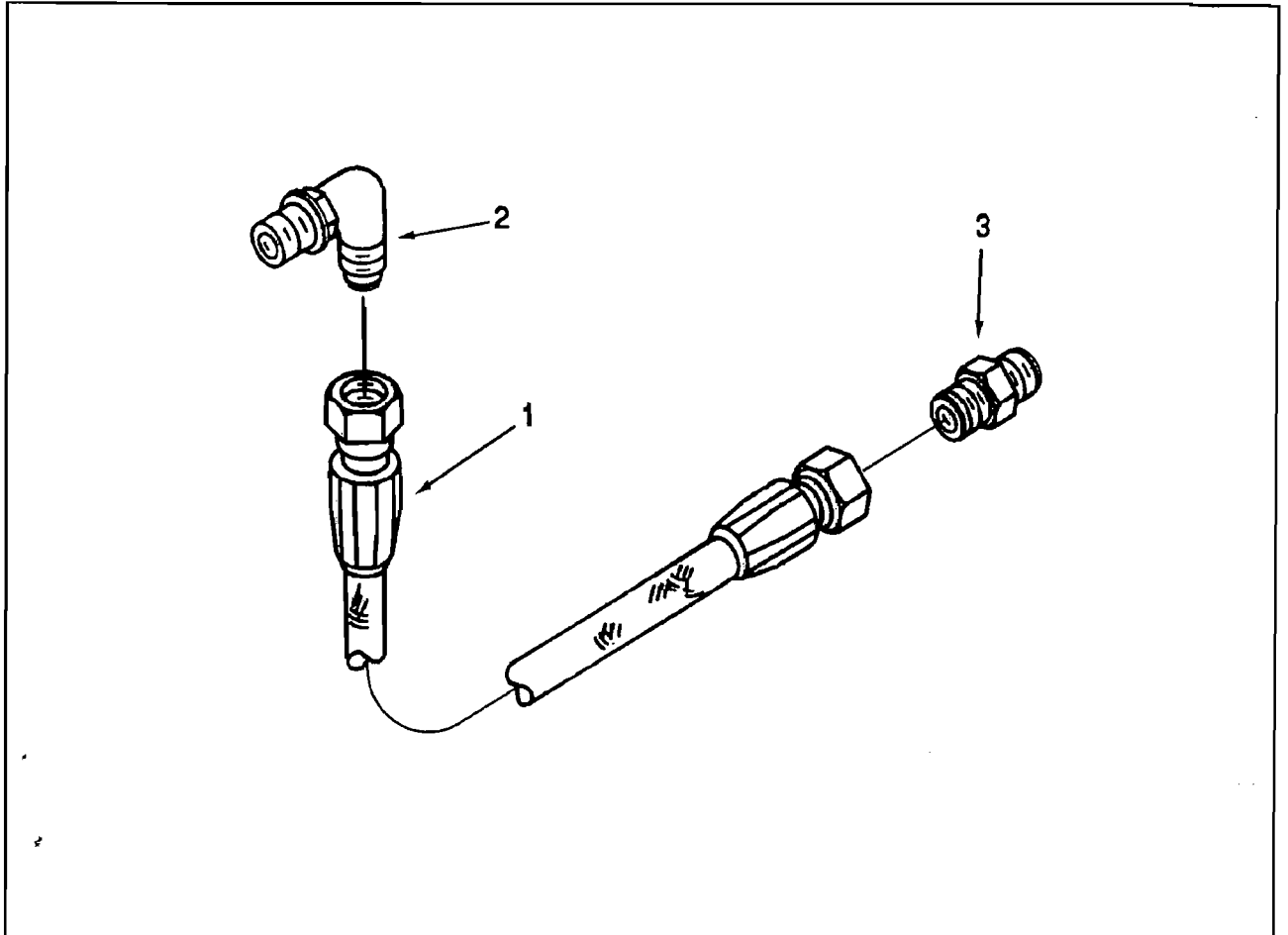

级别 LV	零件号 Part Number	图上标号 Ref No	零件名称 Part Name		数量 Req	备注 Remarks
			中文	英文		
02	129859	2	联接管弯头	ELBOW, MALE UNION	1	
02	129866	3	阳性接头	UNION, MALE	1	
02	AS10018 SS	1	软管	HOSE, FLEXIBLE	1	

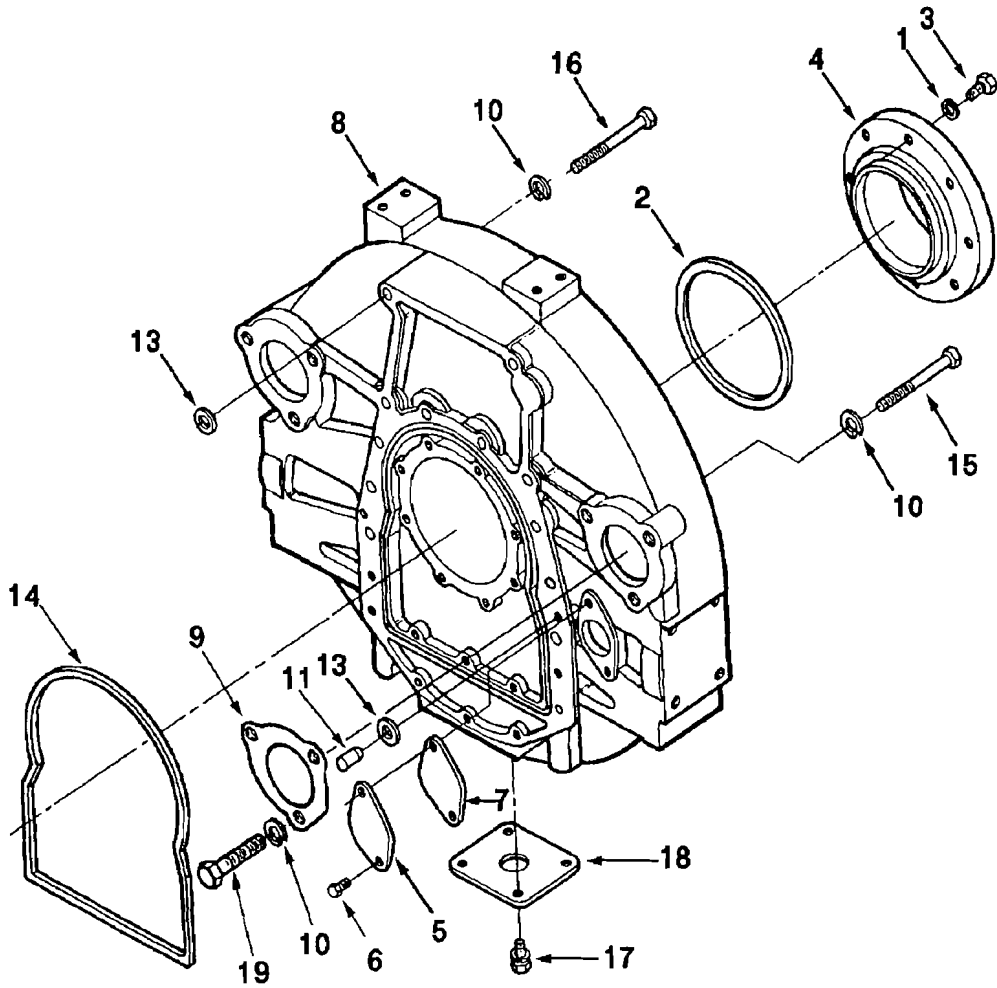

级别 LV	零件号 Part Number	图上标号 Ref No	零件名称 Part Name		数量 Req	备注 Remarks
			中文	英文		
02	AR10591		曲轴后油封	SEAL, REAR OIL CRANKSHAFT	1	
03	S 631	1	平垫圈	WASHER, PLAIN	8	
03	205247	2	O型密封圈	SEAL, O RING	1	
03	205409	3	六角螺栓	SCREW, HEXAGON HEAD CAP	8	
03	3160925	4	曲轴后油封	SEAL, OIL RR CRK	1	
02	3036814	8	飞轮壳	HOUSING, FLYWHEEL	1	
02	3028968		飞轮壳安装	HOUSING, FLYWHEEL MTG	1	
03	9226	11	飞轮壳定位销	DOWEL, FLYWEEL HOUSING	2	
03	172648	13	矩形圈	SEAL, RECTANGULAR RING	14	
03	3096260	14	矩形密封圈	SEAL, RECTANGULAR RING	1	
03	S 103	A 15	六角螺栓	SCREW, HEXAGON HEAD	10	
03	S 144	16	六角螺栓	SCREW, HEXAGON HEAD	2	
03	S 603	10	弹簧垫圈	WASHER, LOCK	12	
02	3201078		飞轮壳盖及安装	COVER, FLYWEEL HOUSING	1	
03	3201056	18	飞轮壳盖	COVER, FLYWEEL HOUSING	1	
03	3010595	17	六角螺栓	SCREW, HEXAGON HEAD CAP	4	
02	3005083		起动机孔盖安装组件	COVER, INDEX HOLE MTG	1	
03	70657	5	飞轮指示孔盖	COVER, FLYWEEL INDEX HOLE	1	
03	3011342	6	带垫螺栓	SCREW, CAPTIVE WASHER	2	
03	3021735	7	衬垫	GASKET, FLYWHEEL HSG	1	
02	MP 5044		起动机孔盖	COVER, STARTER HOLE	1	
03	62182	9	起动机发兰盖板	COVER, STARTER FLANGE	1	
03	S 181	19	六角螺栓	SCREW, HEXAGON HEAD CAP	3	
03	S 603	10	弹簧垫圈	WASHER, LOCK	3	

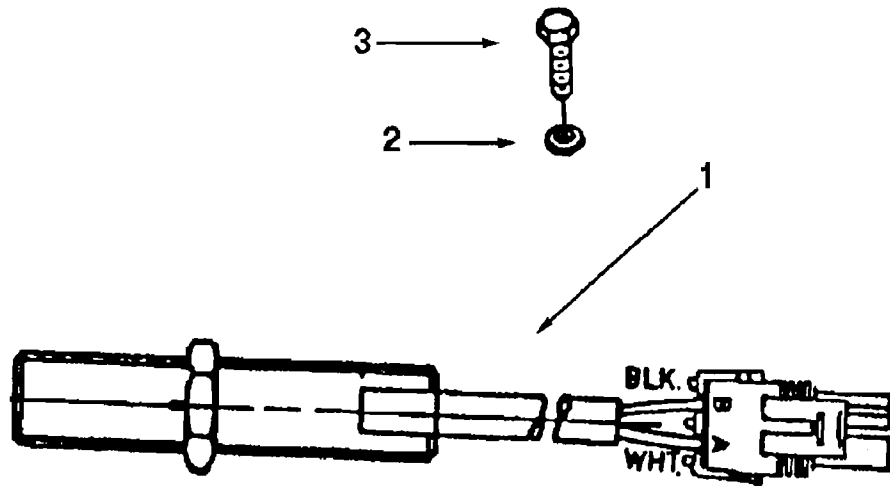

级别 LV	零件号 Part Number	图上标号 Ref No	零件名称 Part Name		数量 Req	备注 Remarks
			中文	英文		
02	3034572	1	电磁传感器	PICKUP, MAGNETIC	1	
02	3201959		传感器孔堵塞	PLUG, MAG PICK-UP HOLE	1	
03	553856	2	衬垫	GASKET, DRAIN PLUG	1	
03	3201759	3	六角螺栓	SCREW, HEXAGON HEAD CAP	1	

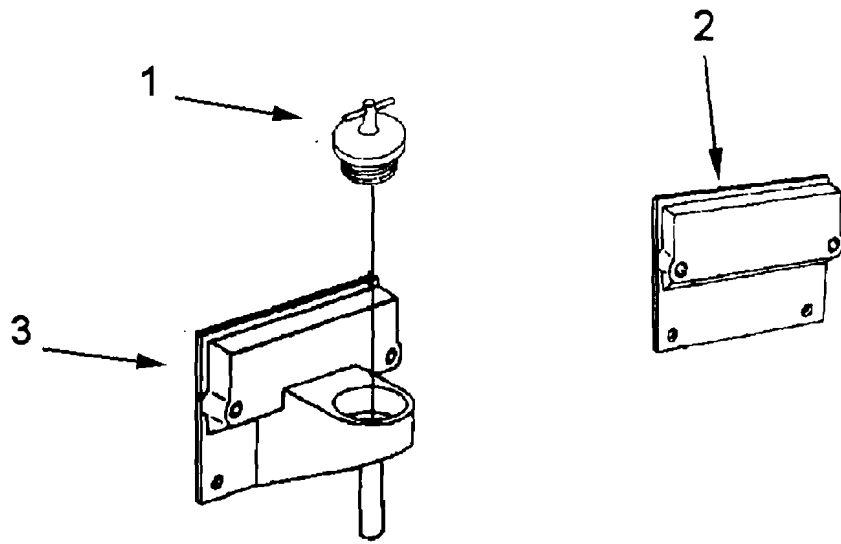

级别 LV	零件号 Part Number	图上标号 Ref No	零件名称 Part Name		数量 Req	备注 Remarks
			中文	英文		
02	3418519	1	加机油口盖总成	CAP FILLER	1	
02	3628755	2	凸轮轴从动件盖	COVER CAMSHAFT	1	
02	3200414 CE		凸轮轴从动件盖	COVER,CAM FOLLOWER	1	
03	101264		加机油口盖	TUBE,OIL FILLER	1	
03	3418880	3	机油管托架	BRACKET,OIL TUBE	1	

图-30

附件驱动 Fuel Pump Drive

FP 4815

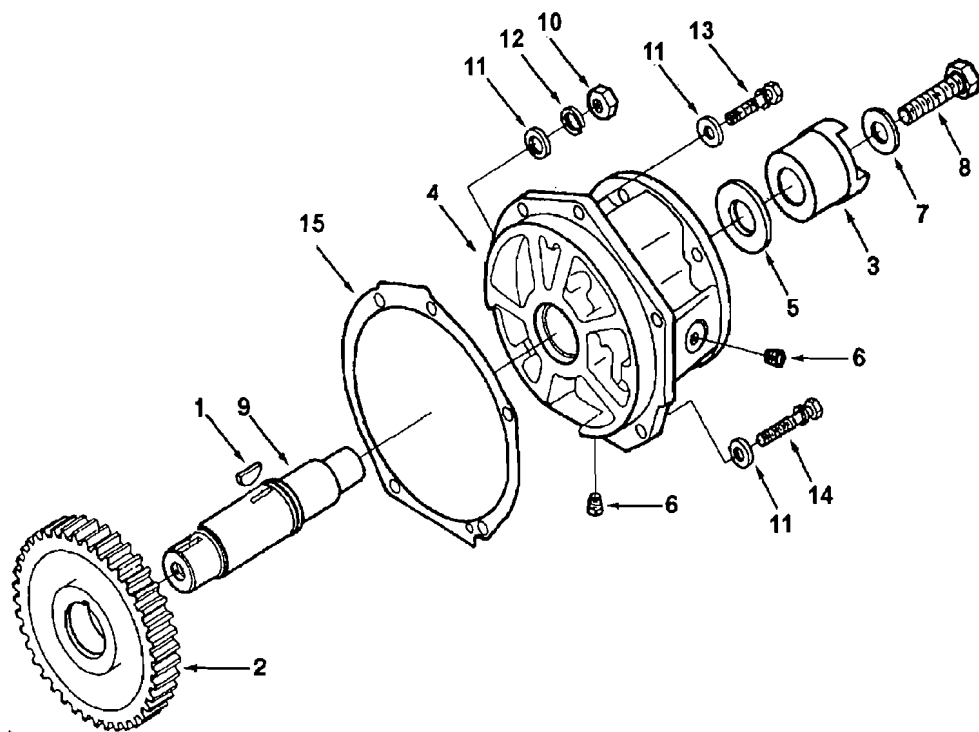

级别 LV	零件号 Part Number	图上标号 Ref No	零件名称 Part Name		数量 Req	备注 Remarks
			中文	英文		
02	3017472		附件驱动安装	DRIVE, ACCESSORY MTG	1	
03	3044413	14	带垫螺栓	SCREW, CAPTIVE WASHER CAP	1	
03	3201693	15	附件驱动支架衬垫	GASKET, ACC DRIVE SUPPORT	1	
03	S 120	13	六角螺栓	SCREW, HEXAGON HEAD CAP	3	
03	S 205	10	六角螺母	NUT, REGULAR HEXAGON	1	
03	S 602	11	平垫圈	WASHER, PLAIN	5	
03	S 604	12	弹簧垫圈	WASHER, LOCK	1	
02	3016734		附件驱动总成	DRIVE, ACCESSORY	1	
03	S 316	1	半园键	KEY, PLAIN WOODRUFF	1	
03	207253	2	辅助传动齿轮	GEAR, ACCESSORY DRIVE	1	
03	3000175	3	燃油泵传动轴接合爪	HUB, JAW COUPLING	1	
03	3009512	4	辅助驱动支承	SUPPORT, ACCESSORY DRIVE	1	
03	3014103	5	挡圈	WASHER, PLAIN	1	
03	3025460	6	管塞	PLUG, PIPE	2	
03	3045136	7	平垫圈	WASHER, PLAIN	1	
03	3045137	8	六角螺栓	SCREW, HEXAGON HEAD CAP	1	
03	3045229	9	附件驱动轴	SHAFT, ACCESSORY DRIVE	1	

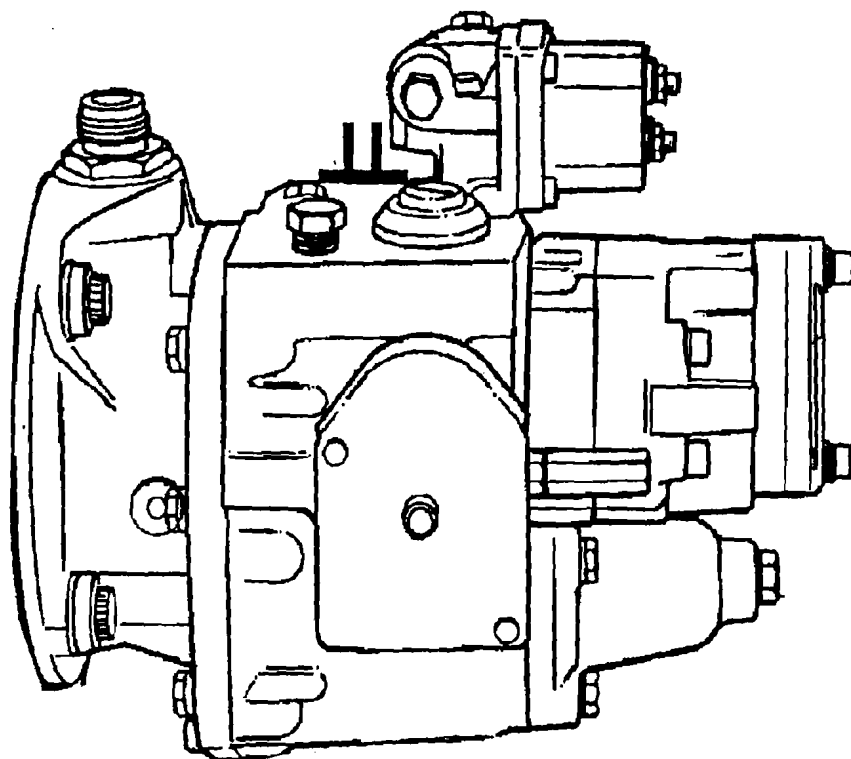

级别 LV	零件号 Part Number	图上标号 Ref No	零件名称 Part Name		数量 Req	备注 Remarks
			中文	英文		
02	3899014	1	燃油泵总成(T.L.N)	PUMP, FUEL(T.L.N)	1	适用于: KTA19-G2(M)
02	3655654	1	燃油泵总成(T.L.N)	PUMP, FUEL(T.L.N)	1	适用于: KTA19-G3(M)
02	3347530	1	燃油泵总成(T.L.N)	PUMP, FUEL(T.L.N)	1	适用于: KTA19-G4(M)

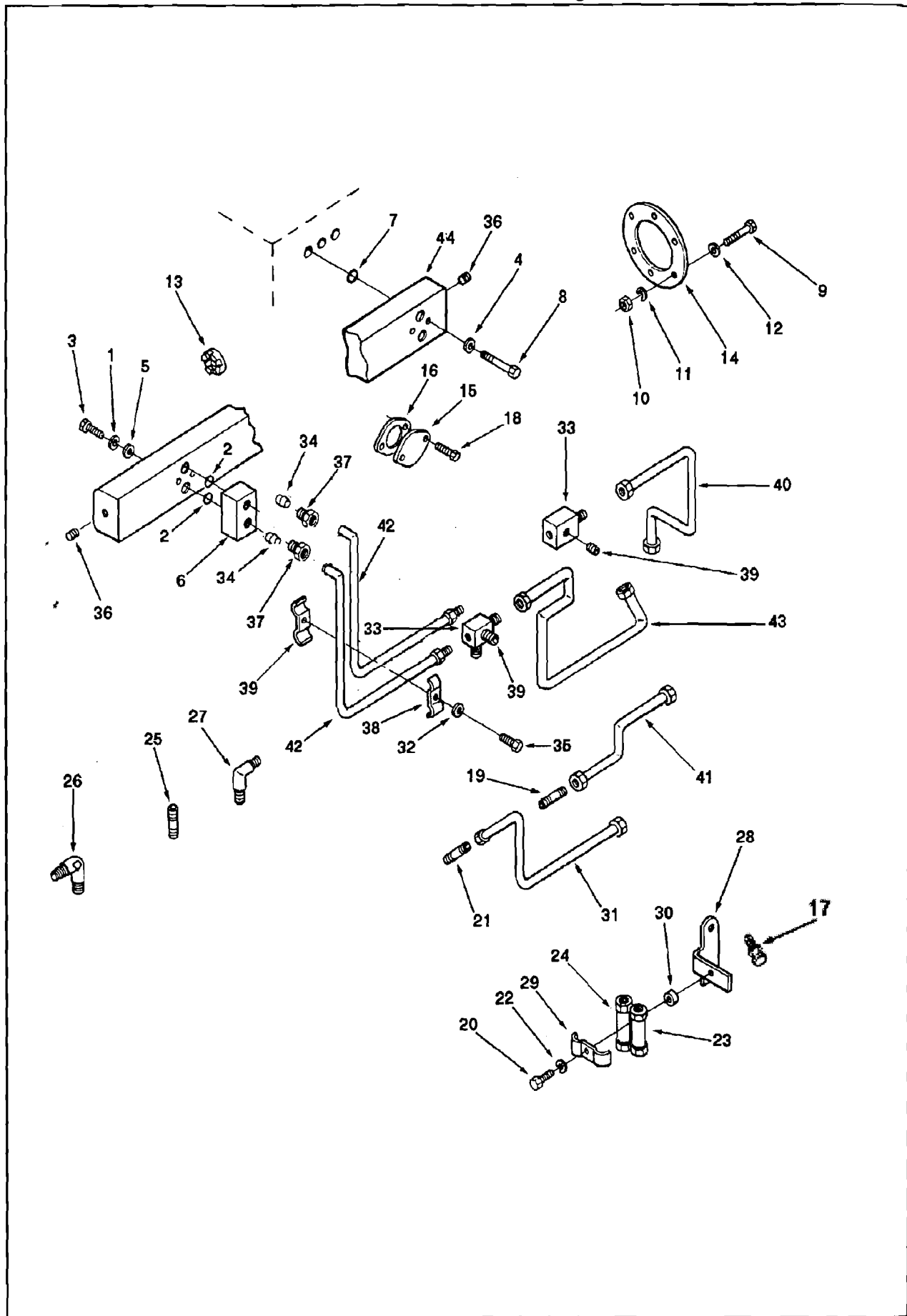

燃油管路 Fuel Tubing

FT 401

零件号 Part Number	图上标号 Ref No	零件名称 Part Name		数量 Req	备注 Remarks
		中文	英文		
AR45224		燃油歧管	MANIFOLD, FUEL	1	适用于: KTA19-G2(M)
100478	2	O型圈	SEAL, O RING	2	
118226	3	内六角螺栓	SCREW, SOCKET HEAD CAP	2	
127018	4	平垫圈	WASHER, PLAIN	12	
128006	5	平垫圈	WASHER, PLAIN	2	
207441	44	燃油歧管	MANIFOLD, FUEL	1	
207442	6	燃油管路联接	CONNECTION, FUEL BLOCK	1	
3001340	7	O型密封圈	SEAL, O RING	12	
3001811	8	十二角螺栓	SCREW, TWELVE POINT CAP	12	
S 607	1	弹簧垫圈	WASHER, LOCK	2	
MP 5015		燃油泵安装	PUMP, FUEL MTG	1	
69324	12	平垫圈	WASHER, PLAIN	8	
3046200	13	爪式联轴节缓冲片	SPIDER, JAW COUPLING	1	
3069103	14	燃油泵衬垫	GASKET, FUEL PUMP	1	
S 140	9	六角螺栓	SCREW, HEXAGON HEAD	4	
S 217	10	六角厚螺母	NUT, HEAVY HEXAGON	4	
S 610	11	弹簧垫圈	WASHER, LOCK	4	
3065822		单向阀和支架安装	CHECK VALVES & MTG	1	
68138	21	阳性管接头	CONNECTOR, MALE	1	
70704	22	垫圈	WASHER, PLAIN	1	
178079	23	单向阀	VALVE, CHECK	1	
185505	24	单向阀	VALVE, CHECK	1	
3010595	17	带垫螺栓	SCREW, CAPTIVE WAS	2	
3200069	28	单向阀支架	BRACKET, CHECK VALVE	1	
3200070	29	单向阀支架	BRKT, CHECK VLV	1	
3201614	30	隔套	SPACER, MOUNTING	1	
3419023	25	管接头	UNION, MALE	1	
3419031	26	弯接头	ELBOW, MALE UNION	1	
3419032	27	弯接头	ELBOW, MALE UNION	1	
S 156 B	20	六角螺栓	SCREW, HEXAGON HEAD	1	
116936	19	普通弯管接头	ELBOW, PLAIN ADAPT	1	
3165728	31	燃油管	TUBE, FUEL SUPPLY	1	
3165734	40	供油管	TUBE, FUEL SUPPLY	1	
3165735	43	供油管	TUBE, FUEL DRAIN	1	
3165740	42	燃油供油管	TUBE, FUEL SUPPLY	2	
3200425	41	回油管	TUBE, FUEL DRAIN	1	

表—
级
LV
02
03
03
03
03
03
03
03
03
02
03
03
03
03

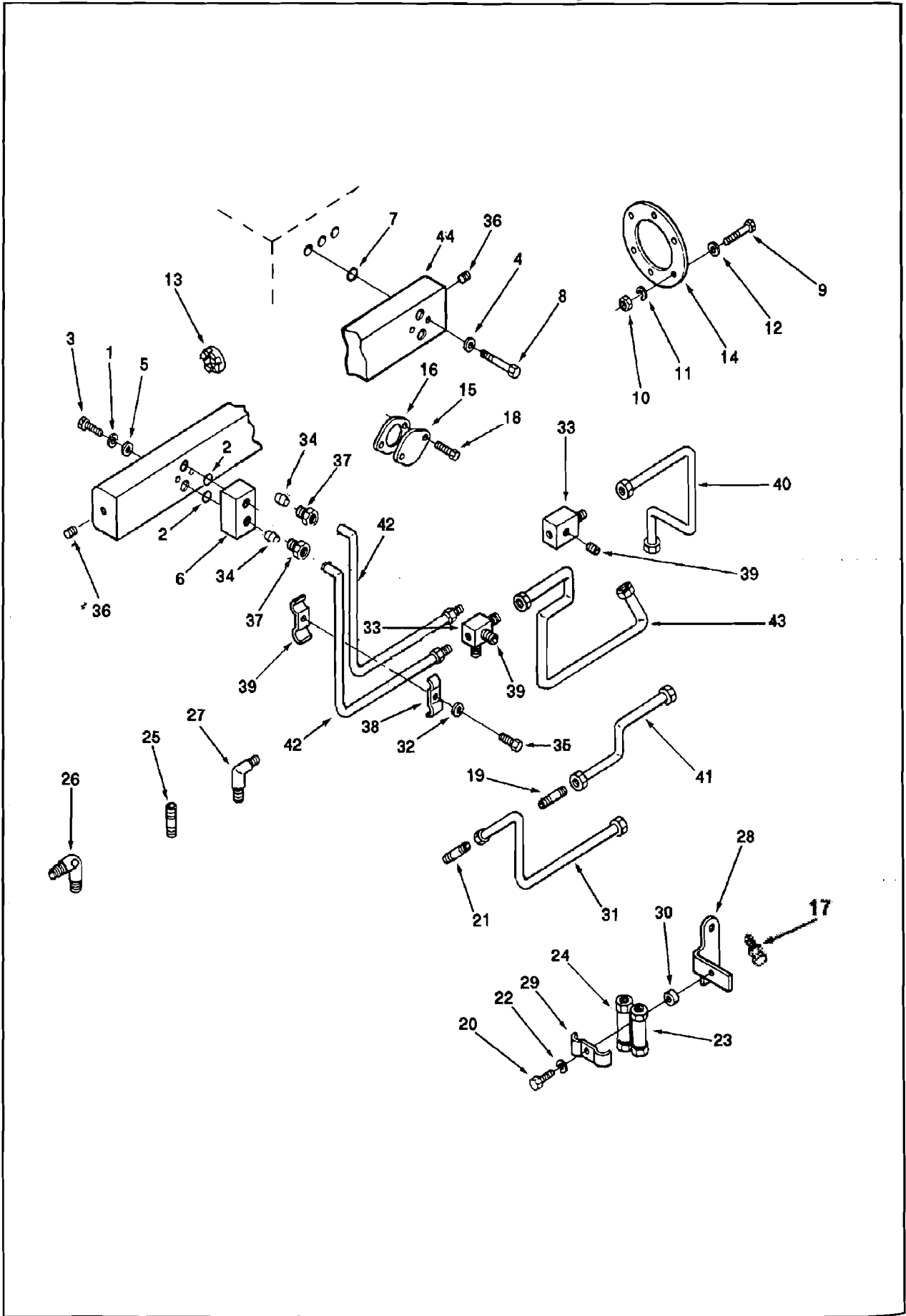

级别 LV	零件号 Part Number	图上标号 Ref No	零件名称 Part Name		数量 Req	备注 Remarks
			中文	英文		
02	4061487		燃油管安装	FUEL, TUBE MOUNTING	1	适用于:
03	127362	32	平垫圈	WASHER, PLAIN	2	KTA19-G2(M)
03	3012478	35	带垫螺栓	SCREW, CAPTIVE WASHER	2	
03	3025460	36	管塞	PLUG, PIPE	2	
03	3031404	37	油管接头	CONNECTOR, TUBE	2	
03	3165842	33	三通接头	TEE, FEMLE ADAPTER	2	
03	3200386	38	油管卡箍	CLAMP, TUBE	2	
03	3200387	39	油管卡箍	CLAMP, TUBE	2	
03	3633046	34	O型密封圈	SEAL, FRRULE	2	
02	MP 5132		空压机进水法兰	FLANGE, COMP WTR INLET	1	
03	207112	15	焊接法兰	FLANGE, WELD	1	
03	207117	16	空压机衬垫	GASKET, AIR COMPRE	1	
03	3014766	18	带垫螺栓	SCREW, HEXAGON HEAD CAP	2	
03	S 606 A		弹簧垫圈	WASHER, LOCK	2	

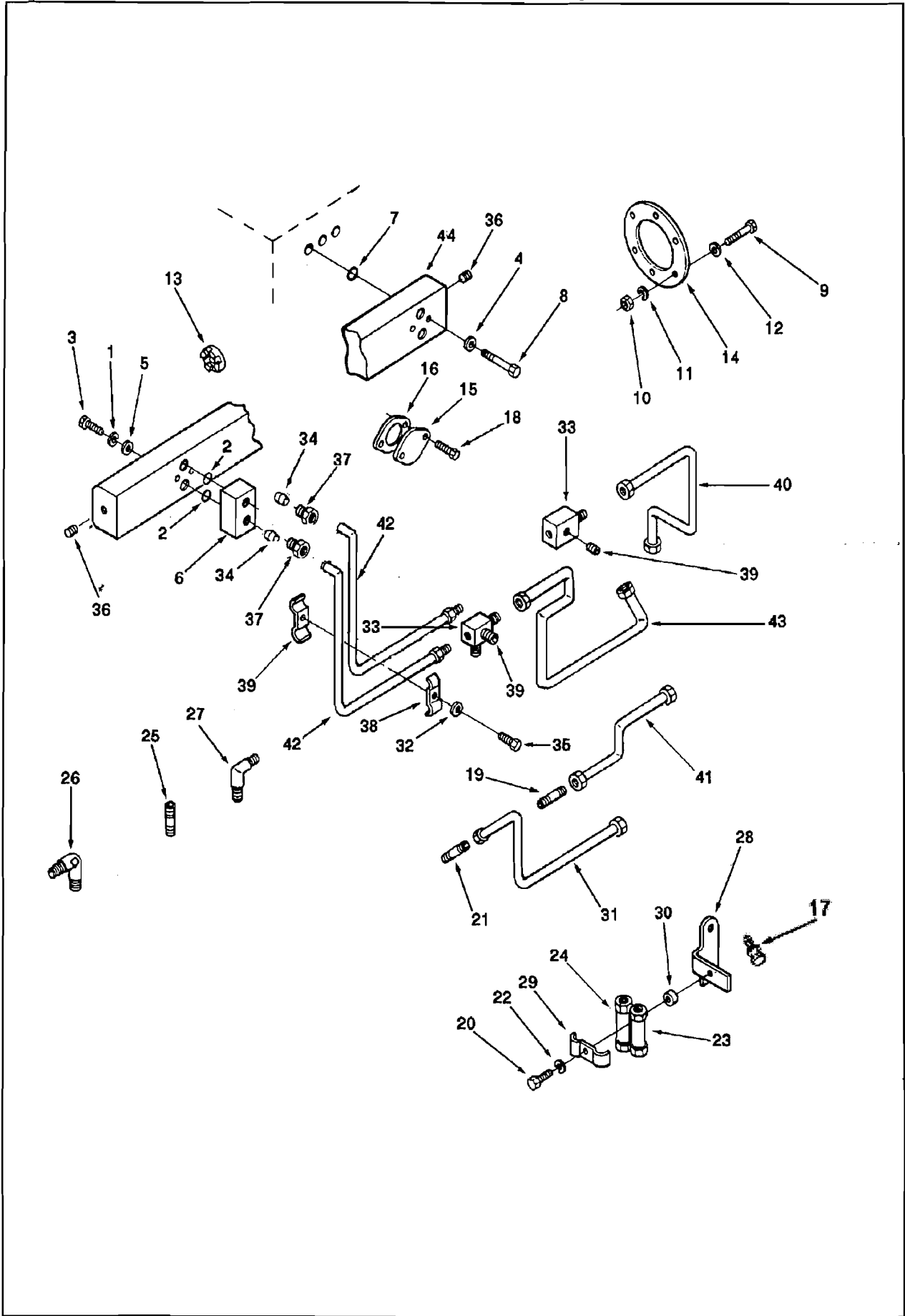

表

1
2
3
4
5
6
7
8
9
10
11
12
13
14
15
16
17
18
19
20
21
22
23
24
25
26
27
28
29
30
31
32
33
34
35
36
37
38
39
40
41
42
43
44

级别 LV	零件号 Part Number	图上标号 Ref No	零件名称 Part Name		数量 Req	备注 Remarks
			中文	英文		
02	AR45224		燃油歧管	MANIFOLD, FUEL	1	适用于:
03	100478	2	O形密封圈	SEAL, O RING	2	KTA19-G3(M)
03	118226	3	内六角螺栓	SCREW, SOCKET HEAD CAP	2	/G4(M)
03	127018	4	平垫圈	WASHER, PLAIN	12	
03	128006	5	平垫圈	WASHER, PLAIN	2	
03	207441	44	燃油歧管	MANIFOLD, FUEL	1	
03	207442	6	燃油管路联接	CONNECTION, FUEL BLOCK	1	
03	3001340	7	O型密封圈	SEAL, O RING	12	
03	3001811	8	十二角螺栓	SCREW, TWELVE POINT CAP	12	
03	S 607	1	弹簧垫圈	WASHER, LOCK	2	
02	MP 5015		燃油泵安装	PUMP, FUEL MTG	1	
03	69324	12	平垫圈	WASHER, PLAIN	4	
03	3046200	13	爪式联轴节缓冲片	SPIDER, JAW COUPLING	1	
03	3069103	14	燃油泵衬垫	GASKET, FUEL PUMP	1	
03	S 140	9	六角螺栓	SCREW, HEXAGON HEAD	4	
03	S 217	10	六角厚螺母	NUT, HEAVY HEXAGON	4	
03	S 610	11	弹簧垫圈	WASHER, LOCK	4	
02	3065823		单向阀安装	CHECK, VALVES & MTG	1	
03	70704	22	垫圈	WASHER, PLAIN	1	
03	178079	23	单向阀	VALVE, CHECK	1	
03	185505	24	单向阀	VALVE, CHECK	1	
03	3010595	17	六角螺栓	SCREW, CAPTIVE WAS	2	
03	3200069	28	单向阀支架	BRACKET, CHECK VALVE	1	
03	3200070	29	单向阀支架	BRKT, CHECK VLV	1	
03	3201614	30	安装隔套	SPACER, MOUNTING	1	
03	3419023	25	阳性管接头	UNION, MALE	2	
03	3419031	26	阳性弯接头	ELBOW, MALE UNION	1	
03	3419032	27	阳性弯管接头	ELBOW, MALE UNION	1	
03	S 156 B	20	六角螺栓	SCREW, HEXAGON HEAD	1	
02	68138	21	阳性管接头	CONNECTOR, MALE	1	
02	116936	19	普通弯管接头	ELBOW, PLAIN ADAPT	1	
02	3165728	31	燃油管	TUBE, FUEL	1	
02	3165734	40	燃油供油管	TUBE, FUEL SUPPLY	1	
02	3165735	43	燃油回油管	TUBE, FUEL DRAIN	1	
02	3165740	42	燃油供油管	TUBE, FUEL SUPPLY	2	
	3200425	41	回油管	TUBE, FUEL DRAIN	1	

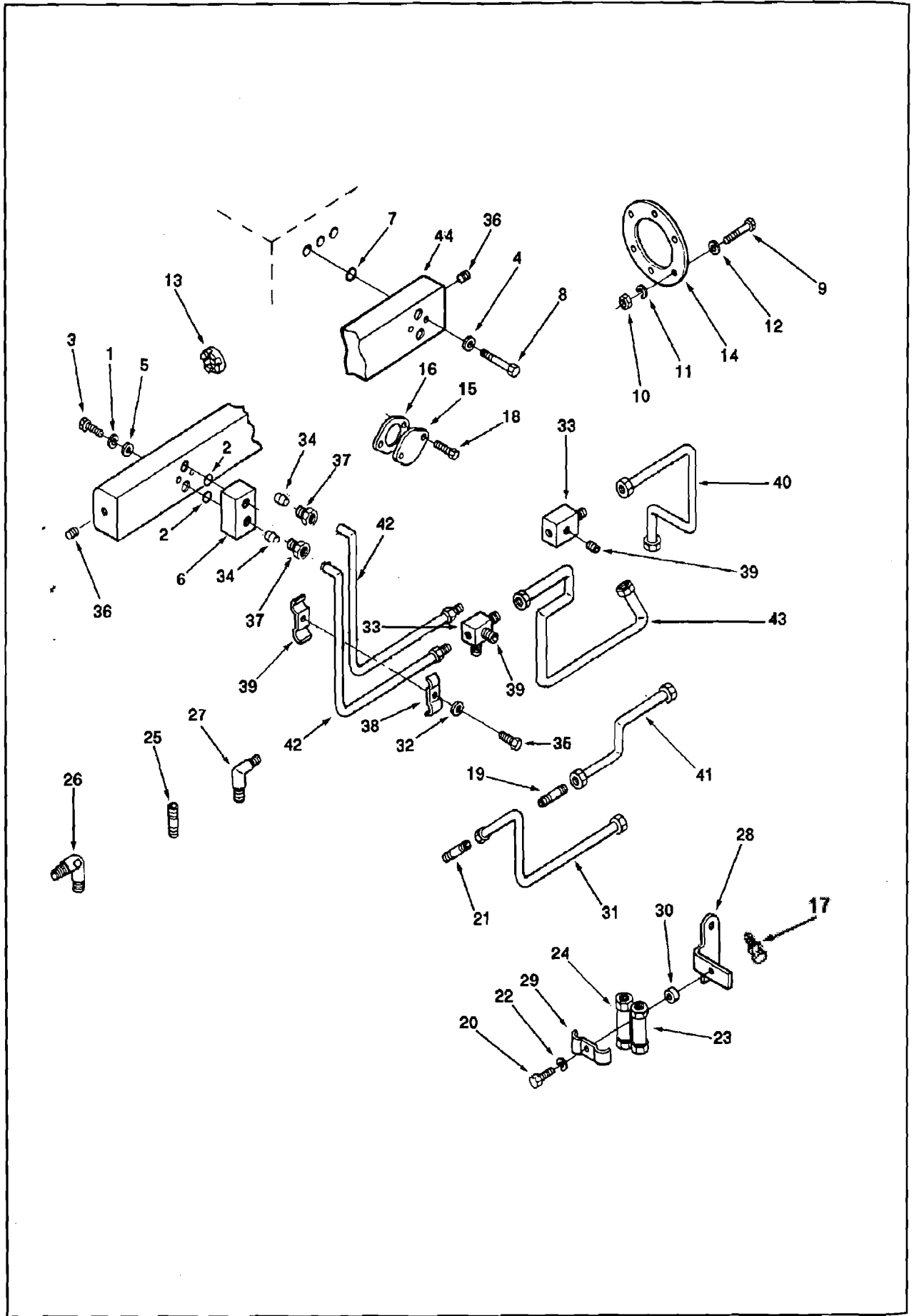

级别 LV	零件号 Part Number	图上标号 Ref No	零件名称 Part Name		数量 Req	备注 Remarks
			中文	英文		
02	4061487		燃油管安装	FUEL, TUBE MOUNTING	1	适用于:
03	127362	32	平垫圈	WASHER, PLAIN	2	KTA19-G3(M)
03	3012478	35	带垫螺栓	SCREW, CAPTIVE WASHER	2	/G4(M)
03	3025460	36	管塞	PLUG, PIPE	2	
03	3031404	37	油管接头	CONNECTOR, TUBE	2	
03	3165842	33	T形管接套	TEE, FEMLE ADAPTER	2	
03	3200386	38	油管卡箍	CLAMP, TUBE	2	
03	3200387	39	油管卡箍	CLAMP, TUBE	2	
03	3633046	34	密封圈	SEAL, FRRULE	2	
02	MP 5132		空压机进水法兰	FLANGE, COMP WTR INLET	1	
03	207112	15	焊接法兰	FLANGE, WELD	1	
03	207117	16	空压机衬垫	GASKET, AIR COMPRE	1	
03	3014766	18	螺栓	SCREW, HEXAGON HEAD CAP	2	
03	S 606 A		弹簧垫圈	WASHER, LOCK	2	

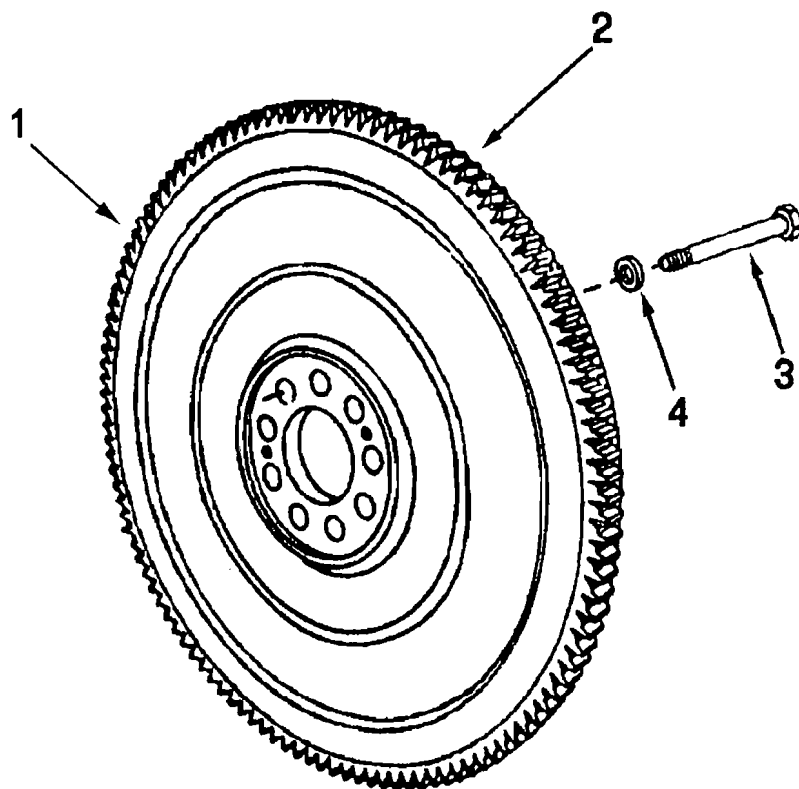

级别 LV	零件号 Part Number	图上标号 Ref No	零件名称 Part Name		数量 Req	备注 Remarks
			中文	英文		
02	3024105		飞轮总成	FLYWHEEL	1	G3
03	5566	1	飞轮齿圈	GEAR FLYWHEEL	1	
03	3005581	2	飞轮	FLYWHEEL	1	G4
02	MP 4980		飞轮安装	FLYWHEEL, MTG	1	
03	200861	4	平垫圈	WASHER, PLAIN	9	
03	207386	3	螺栓	SCREW, HEAD LOCK IN	9	

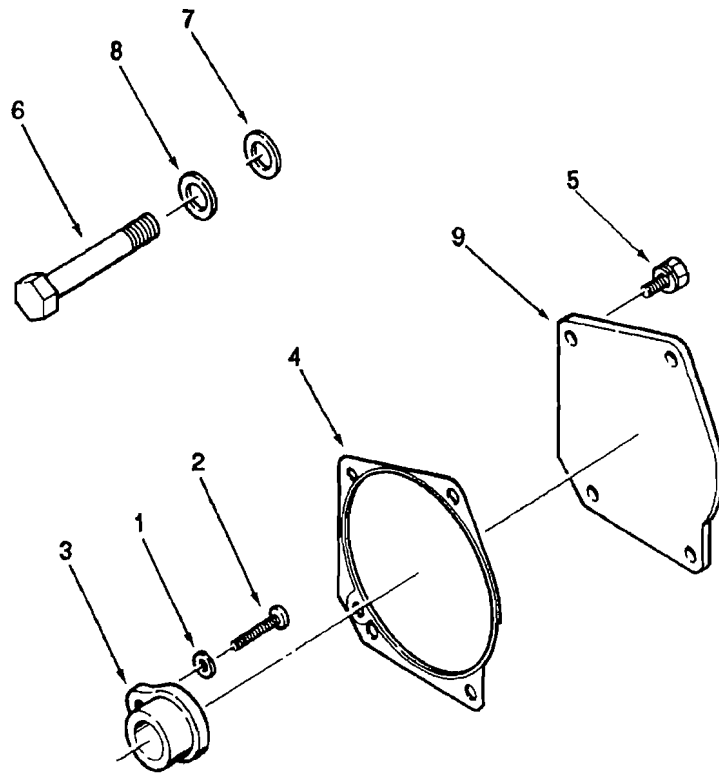

级别 LV	零件号 Part Number	图上标号 Ref No	零件名称 Part Name		数量 Req	备注 Remarks
			中文	英文		
02	MP45143		转向泵镶套总成	INSERT, PUMP DRIVE	1	
03	S 602	1	平垫圈	WASHER, PLAIN	1	
03	129510	2	六角螺栓	SCREW, HEXAGON HEAD CAP	1	
03	3003123	3	镶套	INSERT, PUMP DRIVE	1	
02	3016724		后液压泵盖安装	COVER, REAR HYD MO	1	
03	3007380	4	液压泵衬垫	GASKET, HYDRAULIC	1	
03	3012472	5	带垫圈螺栓	SCREW, CAPTIVE WASHER CAP	4	
02	3017932		惰轮孔塞安装件	IDLER, HOLE PLUG MTG	1	
03	S 123 A	6	六角螺栓	SCREW, HEXAGON HEAD	1	
03	3017346	7	平垫圈	WASHER, PLAIN	1	
03	3200772	8	平垫圈	WASHER, PLAIN	1	
02	3201609	9	液压泵法兰盖	COVER, HYD PUMP FLANGE	1	



表-36-1

热交换器 Heat Exchanger

HX 4073 CE

级别 LV	零件号 Part Number	图上标号 Ref No	零件名称 Part Name		数量 Req	备注 Remarks
			中文	英文		
02	3008861	3	水管接头	CONNECTION, WATER INLET	2	总成装配
02	3008866	4	输水管	TUBE, WATER TRANSFER	1	
02	3011108		热交换器	EXHANGER, HEAT	1	
03	68241	31	管塞	PLUG, ZINC ELECTRODE	6	
03	3011323	32	热交换器壳	HOUSING, HEAT EXCHANGER	1	
03	3011324	33	热交换器盖	COVER, HEAT EXCHANGER	1	
03	3011325	34	热交换器衬垫	GASKET, HEAT EXCHANGER	2	
03	3011226	38	热交换器芯	CORE, COOLER	1	
03	3011329	35	热交换器盖	COVER, HEAT EXCHANGER	1	
03	3011332	36	热交换器衬垫	GASKET, HEAT EXCHANGER	1	
03	3011337	37	O型密封圈	SEAL, O RING	1	
03	3050862	39	带垫螺栓	SCREW, CAPTIVE WAS	12	
03	3050863	40	带垫螺栓	SCREW, CAPTIVE WAS	12	
03	S 610	28	弹簧垫圈	WASHER, LOCK	24	
03	S 610 B	29	管塞	PLUG, ZINC ELECTRODE	4	
02	3012093		水管接头安装	CONNECTION, WTR MTG	2	
03	3008832	5	输水管接头衬垫	GASKET, WTR TRF CONNECTION	1	
03	3012471	6	带垫螺栓	SCREW, CAPTIVE WAS	4	
02	3013440		回水管安装	WTR, RETURN TUBE	1	
03	43828 F	7	抱箍	CLAMP, HOSE	6	
03	63223	8	软管	HOSE, PLAIN	1	
03	107063	9	软管	HOSE, PLAIN	2	
02	3013441		膨胀水箱回水管安装	EXPAN, TANK RTN RUBE	1	
03	43828 A	13	抱箍	CLAMP, HOSE	4	
03	3027706	14	普通软管	HOSE, PLAIN	2	
03	3034856	16	减振垫	ISOLATOR, VIBRATION	2	
03	3034858	15	隔套	SPACER, MOUNTING	1	
03	S 134	10	六角螺栓	SCREW, HEXAGON HEAD	1	
03	S 221	11	六角螺母	NUT, HEAVY HEXAGON	1	
03	S 605	12	弹簧垫圈	WASHER, LOCK	1	
02	3013443		热交换器安装	HEAT, EXCHANGER MTG	1	
03	137972	21	六角螺栓	SCREW, HEXAGON HEAD	4	
03	3165999	20	放水开关	DRAINCOCK	1	
03	S 609	18	弹簧垫圈	WASHER, LOCK	4	

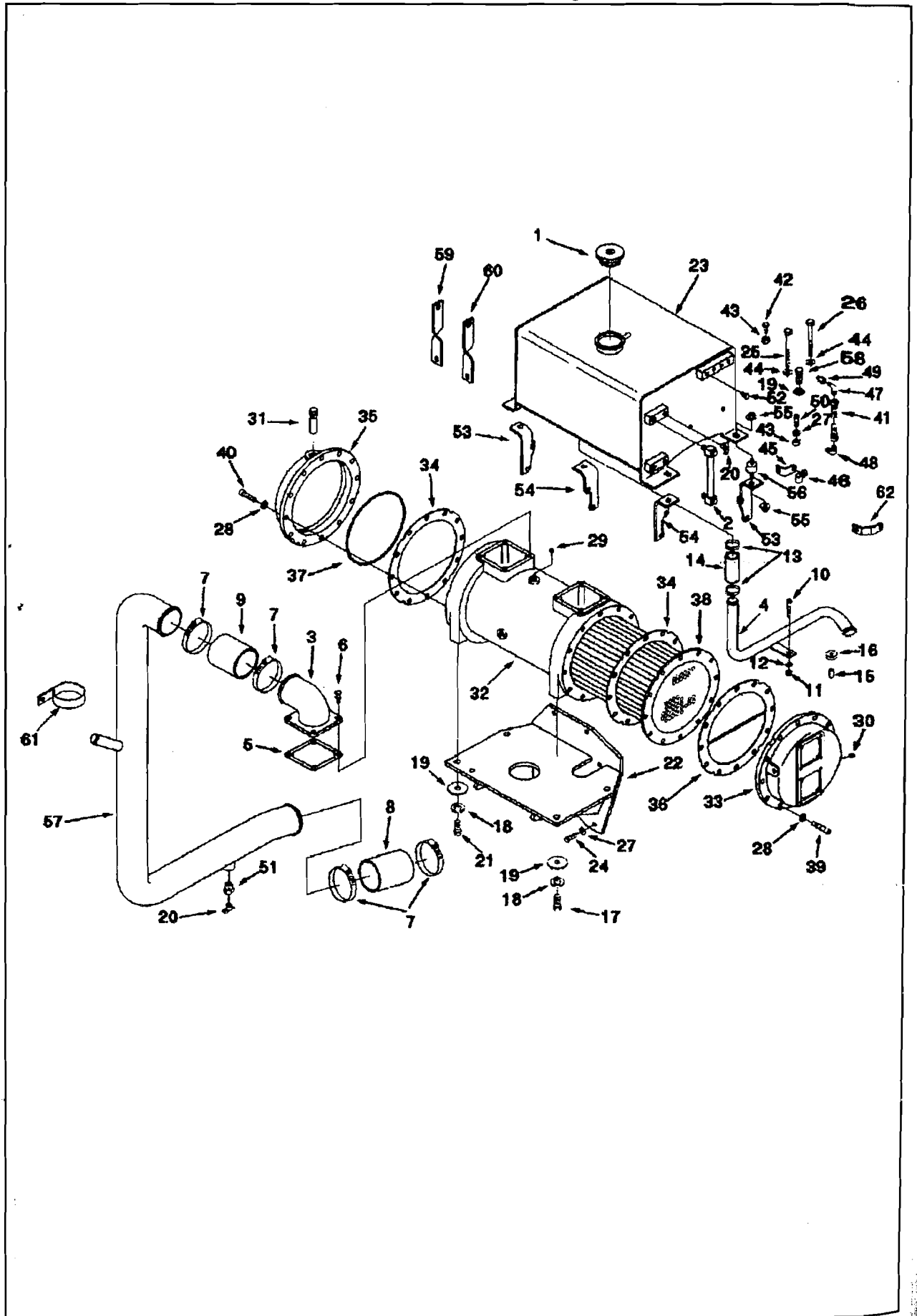
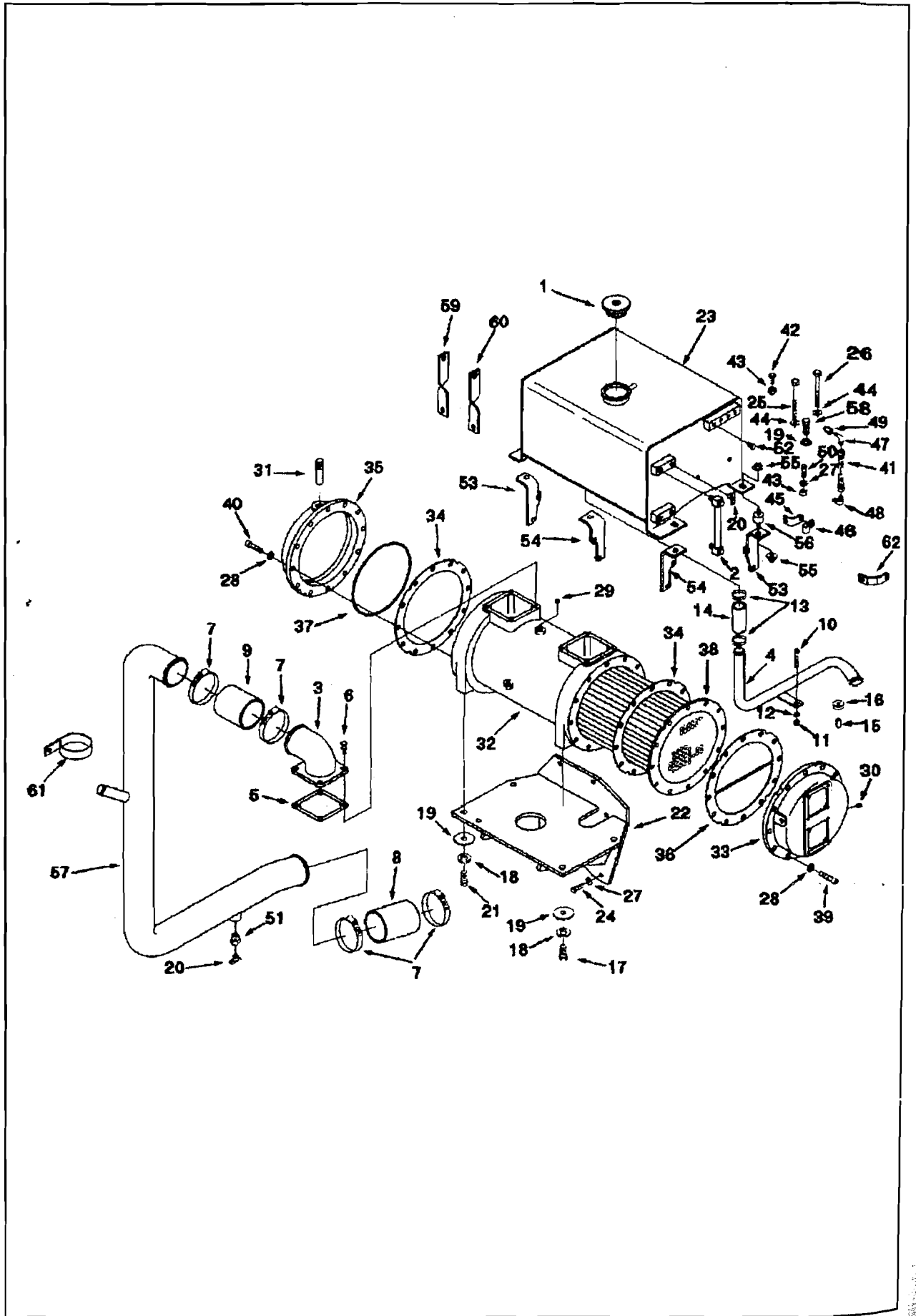

表—36-2

热交换器 Heat Exchanger

HX 4073 CE

级别 LV	零件号		图上标号 Ref No	零件名称 Part Name		数量 Req	备注 Remarks
	Part Number			中文	英文		
02	3021189		22	热交换器支架	BRACKET, HEAT EXCHANGER	1	
02	3036952			热交换器支架安装	MTG, BRACKET	1	
03	127362			平垫圈	WASHER, PLAIN	2	
03	S 112		24	螺栓	SCREW, HEXAGON HEAD	3	
03	S 197		25	六角螺栓	SCREW, HEXAGON HEAD	2	
03	S 199	A	26	六角螺栓	SCREW, HEXAGON HEAD	4	
03	S 604		27	弹簧垫圈	WASHER, LOCK	9	
02	3201389	CE		膨胀水箱安装	MTG, EXPANSION TANK	1	
03	68245		46	夹子	CLIP	1	
03	69901		52	管塞	PLUG, ZINC ELECTRODE	2	
03	109557		44	平垫圈	WASHER, PLAIN	4	
03	116936		47	阳性弯管接头	ELBOW, MALE ADAPTER	2	
03	144372		48	凸式弯管接头	ELBOW, MALE ADAPTER	2	
03	3019573		42	六角螺栓	SCREW, HEXAGON HEAD	4	
03	3024233		53	支架	BRACKET, EXPANSION TANK	2	
03	3024234		54	膨胀水箱支架	BRACKET, EXPANSION TANK	2	
03	3034856		56	减振垫	ISOLATOR, VIBRATION	8	
03	3034858		15	隔套	SPACER, MOUNTING	4	
03	3165999		20	放水开关	DRAINCOCK	1	
03	AS 5011	SS		软管	HOSE, PLAIN	1	
03	AS 5028	SS		软管	HOSE, PLAIN	1	
03	S 134		10	六角螺栓	SCREW, HEXAGON HEAD	4	
03	S 155		50	六角螺栓	SCREW, HEXAGON HEAD	4	
03	S 221		11	六角螺母	NUT, HEAVY HEXAGON	4	
03	S 605		12	弹簧垫圈	WASHER, LOCK	4	
03	S 610			弹簧垫圈	WASHER, LOCK	8	
03	S 906	B	51	异径管衬套	BUSHING, REDUCING PIPE	1	
02	3202138		57	水泵输水管	TUBE, WATER TRANSFER	1	
02	3202141			水泵输水管安装	MTG, TUBE WATER TRANSFER	1	
03	3202126		59	水管支架	BRACE, TUBE	1	
03	3202127		60	水管支架	BRACE, TUBE	1	
03	3202132		61	夹子	CLIP	2	
03	S 112		24	螺栓	SCREW, HEXAGON HEAD	2	
03	S 205		43	六角厚螺母	NUT, HEAVY HEXAGON	2	
03	S 602		44	平垫圈	WASHER, PLAIN	4	
03	S 604		27	弹簧垫圈	WASHER, LOCK	2	
02	3655883		23	膨胀水箱和加水盖总成	EXPAN TANK & FILTER	1	

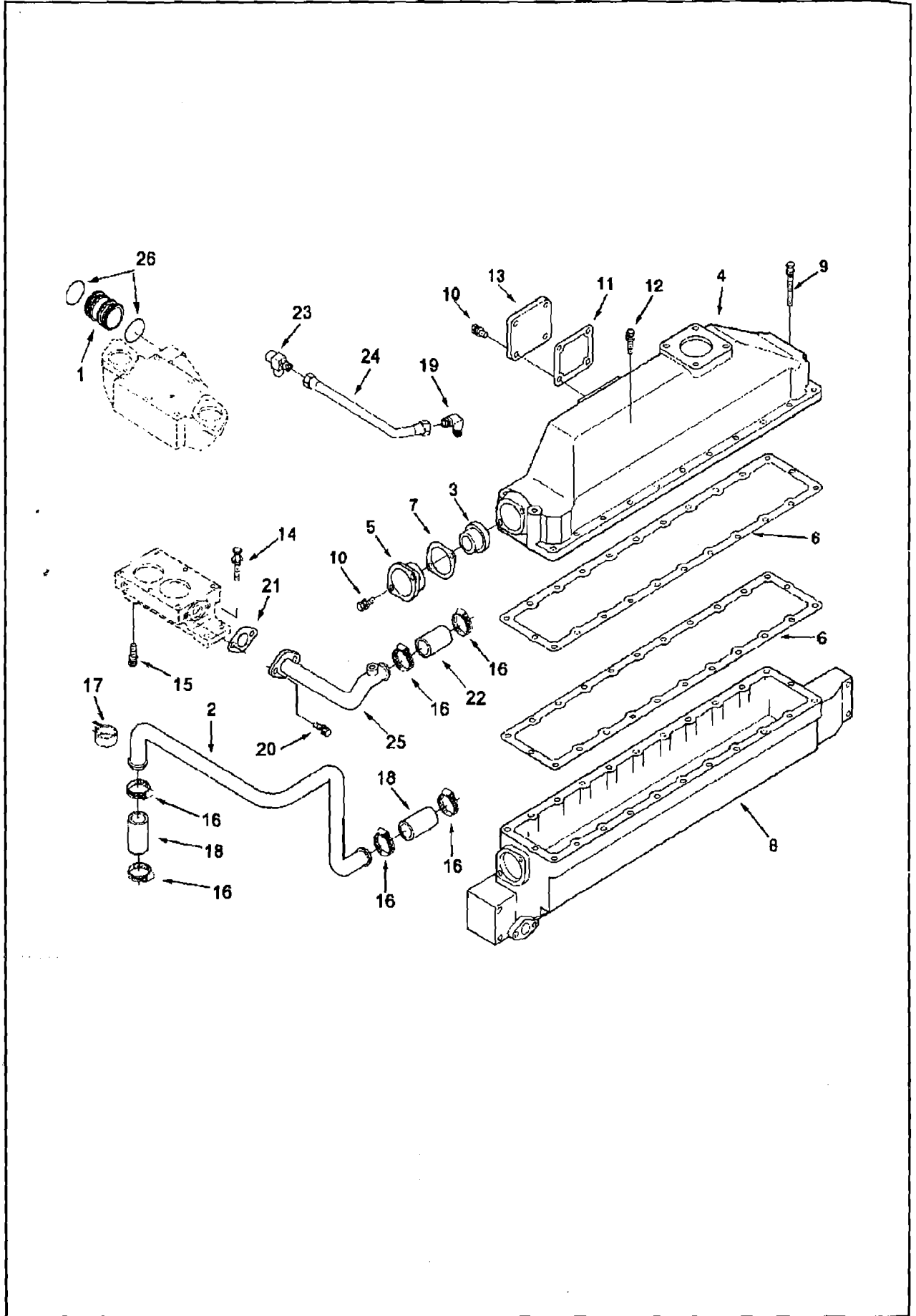

表一37

进气管 Air, Intake

IM 4006

级别 LV	零件号 Part Number	图上标号 Ref No	零件名称 Part Name		数量 Req	备注 Remarks
			中文	英文		
02	207378	1	输水管	TUBE, WASTER TRANSFER	1	
02	3002179	2	输水管	TUBE, WATER TRANSFER	1	
02	3009562		中冷器室盖	COVER, AFTERCOOLER HSG	1	
03	127362		平垫圈	WASHER, PLAIN	28	
03	172640	12	十二角螺栓	SCREW, TWELVE POINT CAP	21	
03	206808	3	水接头密封圈	SEAL, WATER CONNECTION	2	
03	207222	9	十二角螺栓	SCREW, TWELVE POINT CAP	3	
03	3001300	4	中冷器盖	COVER, AFTERCOOLER	1	
03	3001301	5	密封环	RETAINER, SEAL	2	
03	3001304	6	中冷器室衬垫	GASKET, AFT HOUSING	2	
03	3001305	7	水管接头衬垫	GASKET, CONNECTION	2	
03	3005594		平垫圈	WASHER, PLAIN	4	
03	3010596	10	带垫圈螺栓	SCREW, CAPTIVE WAS	8	
03	3010927	8	中冷器室	HOUSING, AFTERCOOLER	1	
03	3032161	11	衬垫	GASKET, CONN	1	
03	3200783	13	盖板	COVER, AIR INTAKE	1	
03	S 604		弹簧垫圈	WASHER, LOCK	24	
02	3016723		节温器壳支架安装	MTG, SUPPORT THERM HSG	1	
03	127362		平垫圈	WASHER, PLAIN	2	
03	3012472	16	带垫圈螺栓	SCREW, CAPTIVE WASHER CAP	2	
03	S 141	14	螺栓	SCREW, HEXAGON HEAD	2	
03	S 604		弹簧垫圈	WASHER, LOCK	2	
02	3016727		水泵进水管安装	MTG, TUBE WTR PUMP	1	
03	3010922	18	夹子	CLLP	1	
03	3026806	17	抱箍	CLAMP, HOSE	4	
03	3818271	19	软管	HOSE, PLAIN	2	
03	S 602		平垫圈	WASHER, PLAIN	1	
02	3016728		中冷器接管	CONNECTION, AFTERCOOLER	1	
03	9539	A 24	普通软管	HOSE, PLAIN	1	
03	143950		阳性接头	CONNECTOR, MALE	1	
03	144372	20	凸式弯管接头	ELBOW, MALE ADAPTER	1	
03	3010595	21	带垫螺栓	SCREW, CAPTIVE WAS	2	
03	3010926	23	法兰衬垫	GASKET, FLANGE	1	
03	3026806	17	抱箍	CLAMP, HOSE	2	
03	3175687	25	异径三通接头	TEE, STREET PIPE	1	
03	3201384	26	通气管	TUBE, VENT	1	
03	3201401	27	输水接管	CONNECTION, WATER TRANSF	1	
02	3028291	28	O型密封圈	SEAL, O RING	2	

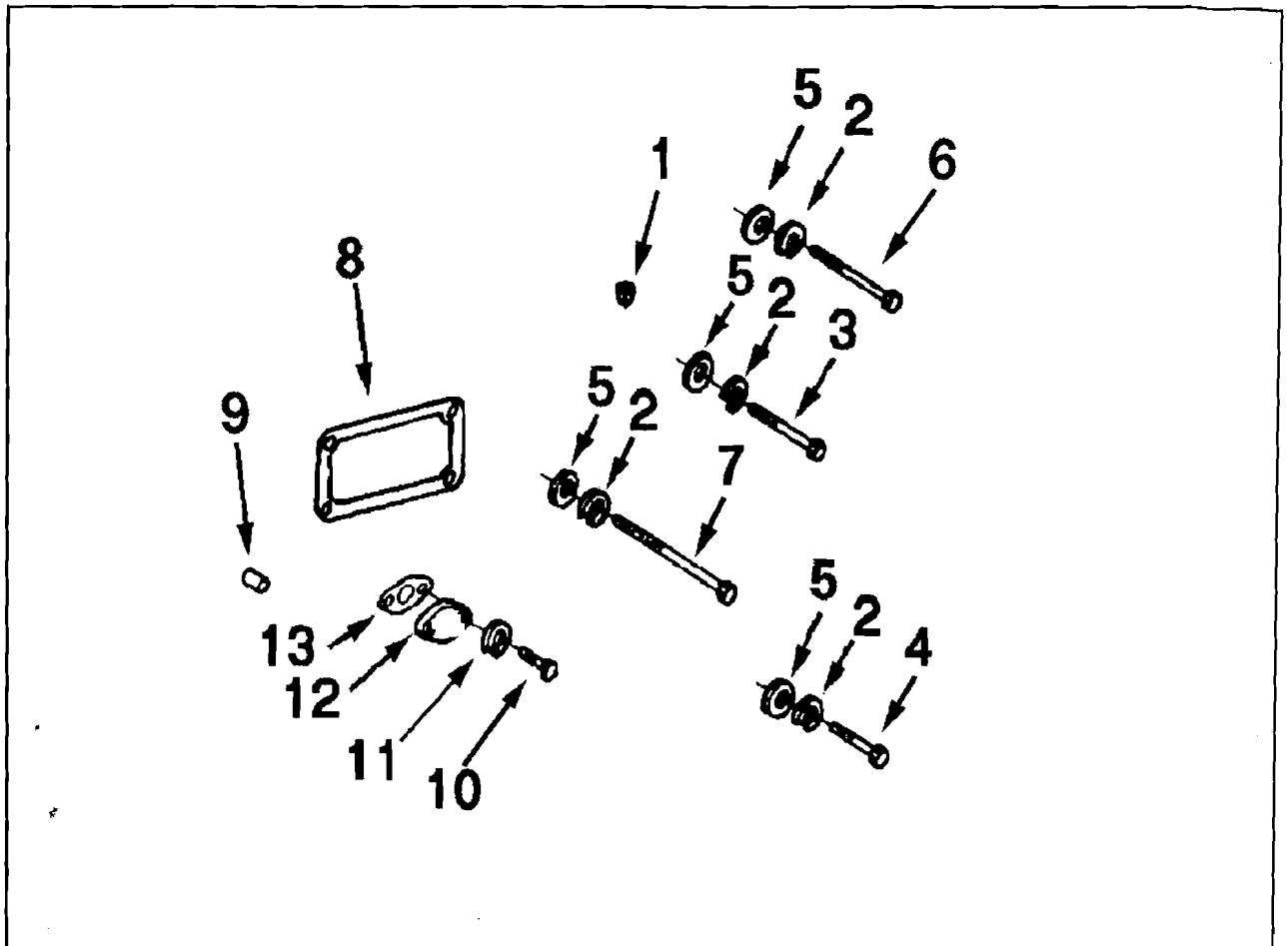

级别 LV	零件号 Part Number	图上标号 Ref No	零件名称 Part Name		数量 Req	备注 Remarks
			中文	英文		
02	3008466	1	管塞	PLUG, PIPE	1	
02	3011510		中冷器室安装	MTG HOUSING AFTERCOOLER	1	
03	3042890	3	六角螺栓	SCREW, HEXAGON HEAD	12	
03	123204	4	六角螺栓	SCREW, HEXAGON HEAD	2	
03	S 602	5	平垫圈	WASHER, PLAIN	24	
03	137868	6	六角螺栓	SCREW, HEXAGON HEAD CAP	2	
03	137872	7	六角螺栓	SCREW, HEXAGON HEAD CAP	8	
03	206277	8	进气管衬垫	GASKET, AIR MANIFOLD	6	
03	3014304	9	矩形密封圈	SEAL, RECTANGULAR RING	12	
03	S 604	2	弹簧垫圈	WASHER, LOCK	24	
02	3012560		空压机盖板	COVER, AIR COMP	1	
03	3011693	12	盖板	PLATE, COVER	1	
03	3201388	13	法兰衬垫	GASKET, FLANGE	1	
03	S 103 D	10	六角螺栓	SCREW, HEXAGON HEAD CAP	2	
03	S 604	11	弹簧垫圈	WASHER, LOCK	2	

记 录

A series of horizontal lines for writing, forming a ruled page.

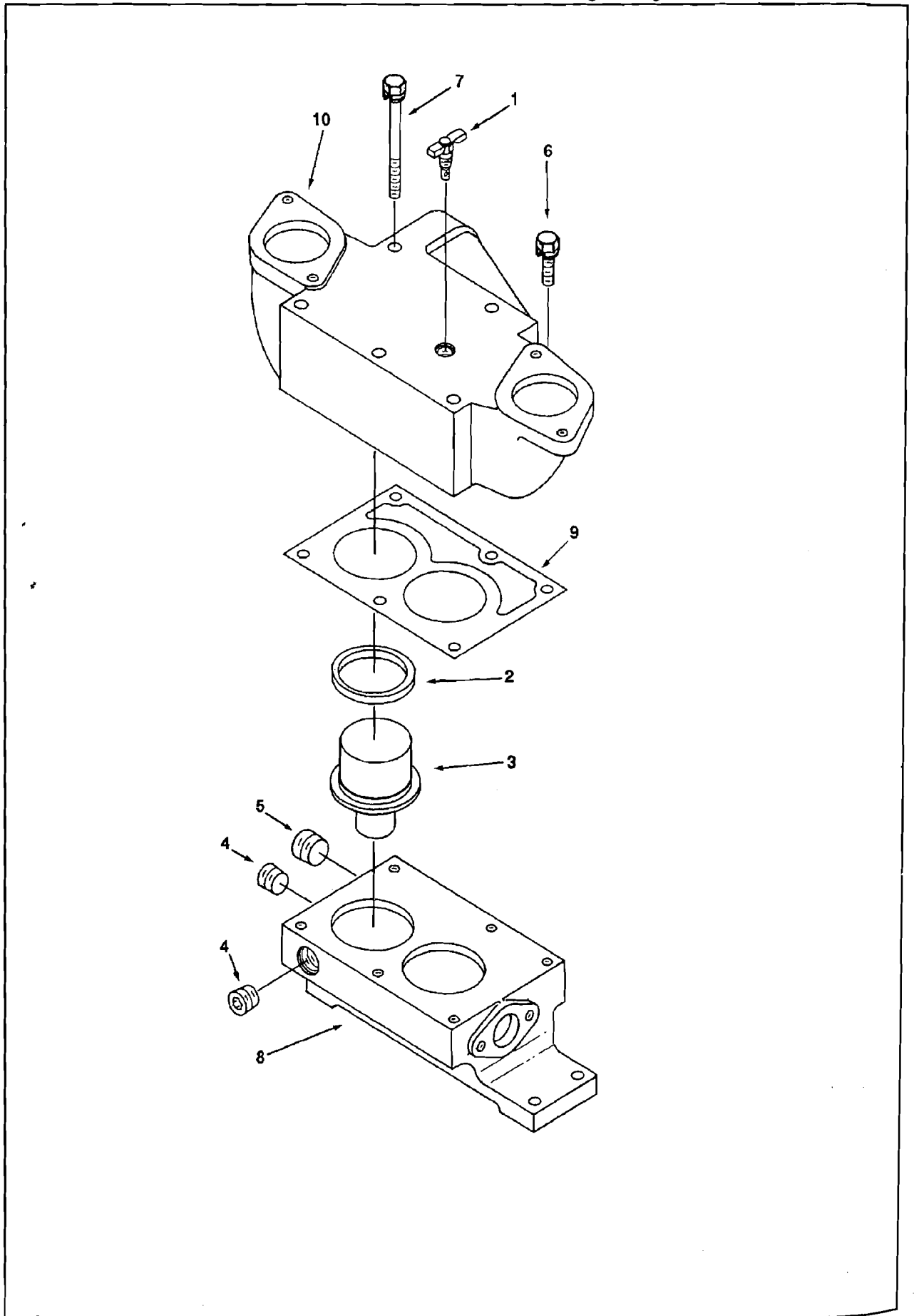

级别 LV	零件号 Part Number	图上标号 Ref No	零件名称 Part Name		数量 Req	备注 Remarks
			中文	英文		
02	3065803		节温器.壳.支架总成	THERMOSTAT HOUSING	1	
03	186780	2	节温器密封圈	SEAL, THERMOSTAT	2	
03	3008468	4	管塞	PLUG, PIPE	4	
03	3008469	5	管塞	PLUG, PIPE	2	
03	3010596	6	带垫圈螺栓	SCREW, CAPTIVE WAS	1	
03	3010597	7	带垫螺栓	SCREW, CAPTIVE WAS	5	
03	3010916	8	节温器壳体支架	SUPPORT, THERMO HSG	1	
03	3010918	9	节温器壳衬垫	GASKET, THERMOSTA	1	
03	3010933	10	节温器壳	HOUSING, THERMOSTAT	1	
03	3076489	3	节温器	THERMOSTAT	2	
03	3165998	1	放水开关	DRAINCOCK	1	

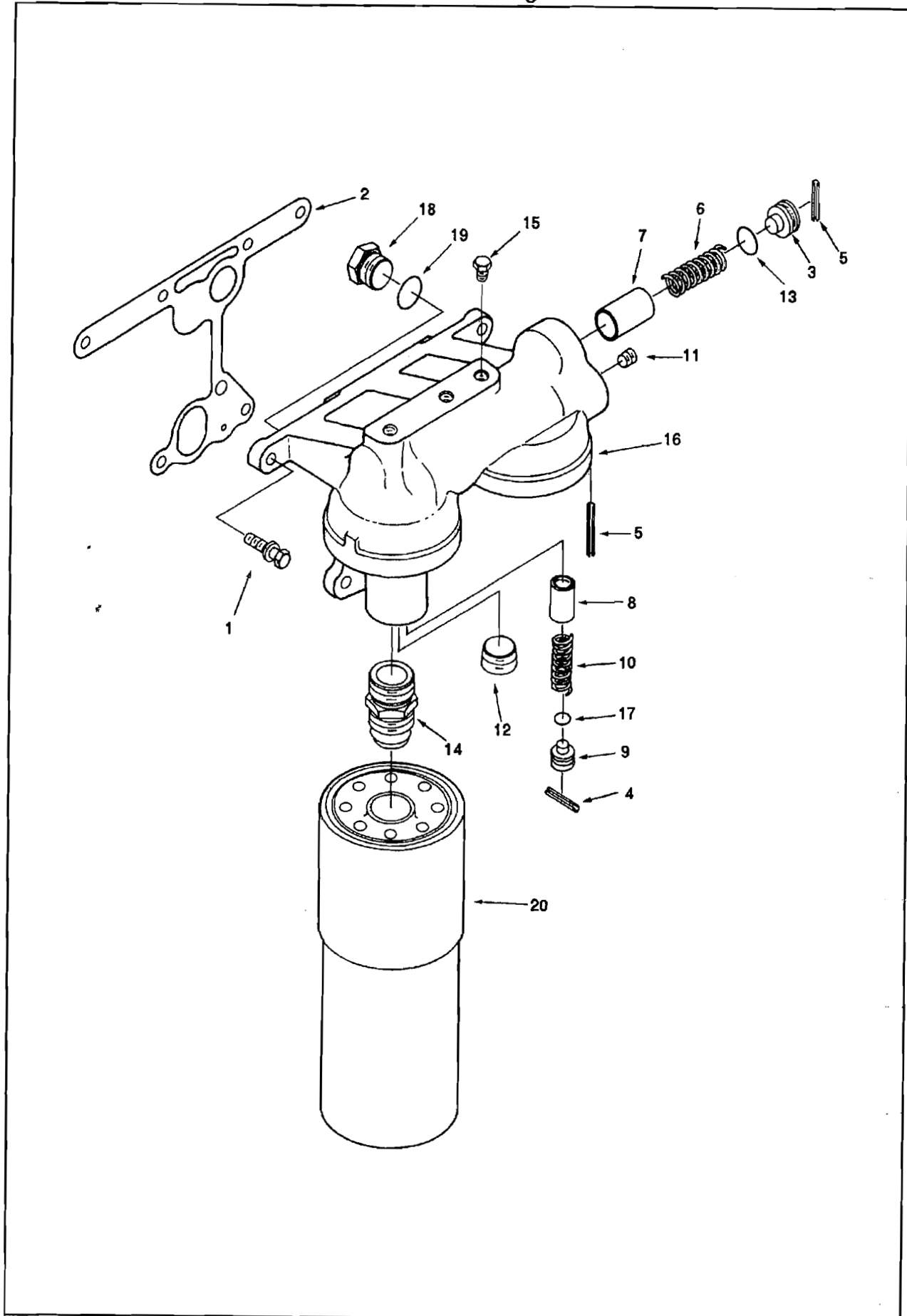

级别 LV	零件号 Part Number	图上标号 Ref No	零件名称 Part Name		数量 Req	备注 Remarks
			中文	英文		
02	MP 5005		机油滤清器座安装	HEAD, LUB FILFER	1	
03	3040838	1	带垫螺栓	SCREW, CAPTIVE WAS	6	
03	3200977	2	机油滤清器衬垫	GASKET, LUB OIL FI	1	
02	3200965		机油滤清器座	LUB, OIL FILTER H	1	
03	69533	3	压力调节器制动器	STOP, PRESSURERE	1	
03	161737	4	滚柱销	PIN, ROLL	1	
03	205345	5	滚柱销	PIN, ROLL	2	
03	205346	6	压缩弹簧	SPRING, COMPRESSIO	1	
03	205347	7	旁通阀柱塞	PLUNGER, BYPASS	1	
03	205348	8	活塞冷却柱塞	PLUNGER, PISTON C	1	
03	205350	9	护圈塞	PLUG, RETAINER	1	
03	3007170	10	活塞冷却器弹簧	SPRING, PISTON CO	1	
03	3008466	11	管塞	PLUG, PUMP	1	
03	3008470	12	管塞	PLUG, PIPE	2	
03	3029820	13	O型密封圈	SEAL, O RING	1	
03	3034578	14	滤清器座接头	ADAPTER, FILTER HE	2	
03	3201125	17	O型密封圈	SEAL ORING	1	
03	3200963		机油滤清器座	LUB, OIL FILTER HEAD	1	
04	3025458	15	管塞	PLUG, PIPE	3	
04	3202156	16	机油滤清器座	HEAD, LUB OIL FILTER	1	
03	3201583		螺塞	PLUG, THREADED	1	
04	3040911	18	螺塞	PLUG, THREADED	1	
04	3201585	19	O型密封圈	SEAL, O RING	1	
02	3889310	20	机油滤清器芯总成	ELEMENT, LUB OIL FILTER	2	

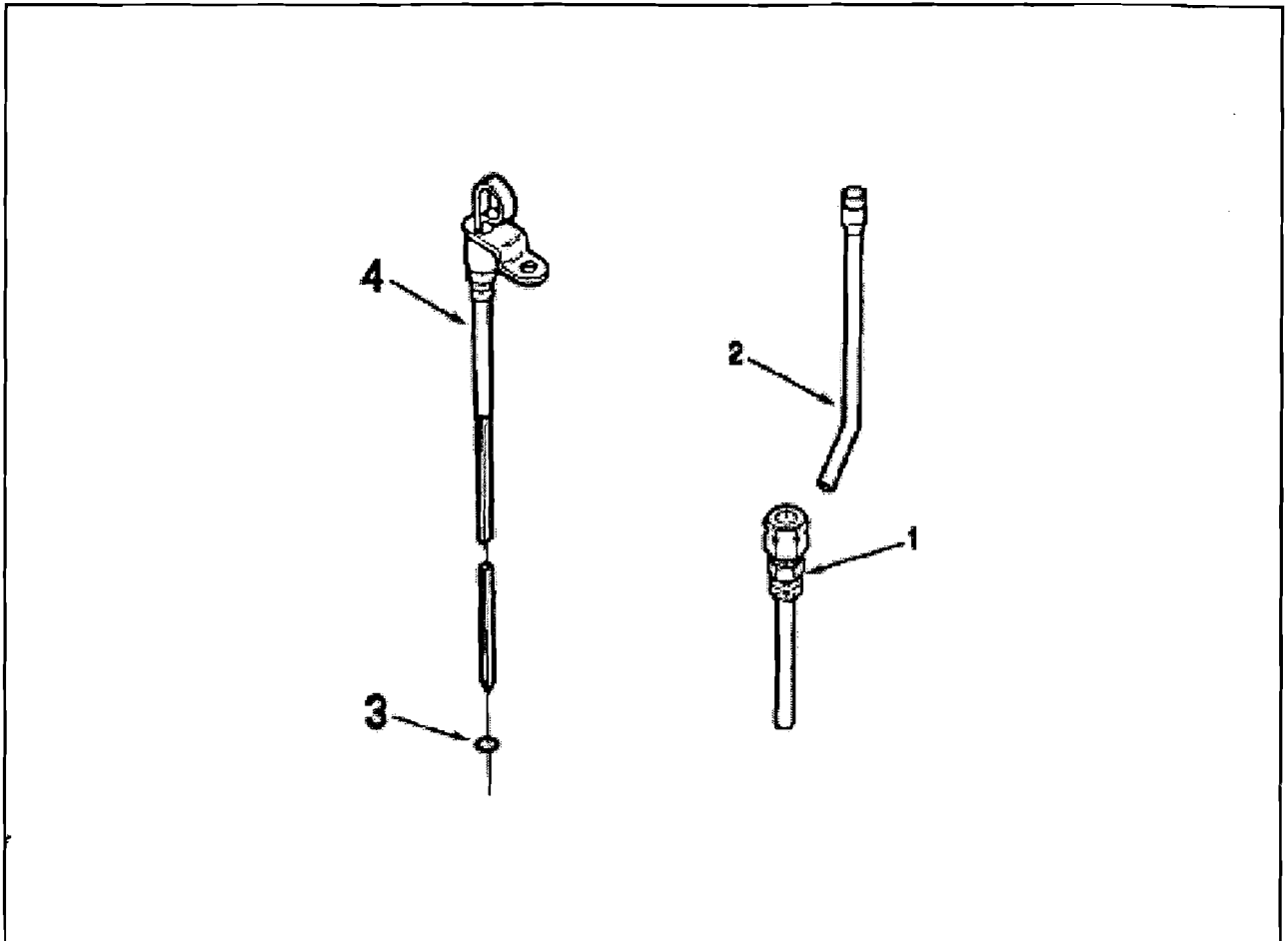

级别 LV	零件号 Part Number	图上标号 Ref No	零件名称 Part Name		数量 Req	备注 Remarks
			中文	英文		
02	3419239	2	机油尺管	TUBE,OIL GAUGE	1	
02	3419241		机油尺管	TUBE,OIL GAUGE	1	
03	3046201		O型圈	SEAL,O RING	1	
03	3655211	1	机油尺管子	TUBE,OIL GAUGE	1	
02	3042083		机油尺	DIPSTICK	1	
03	108172	3	O型密封圈	SEAL,O RING	1	
03	3041136	4	机油尺	DIPSTICK	1	

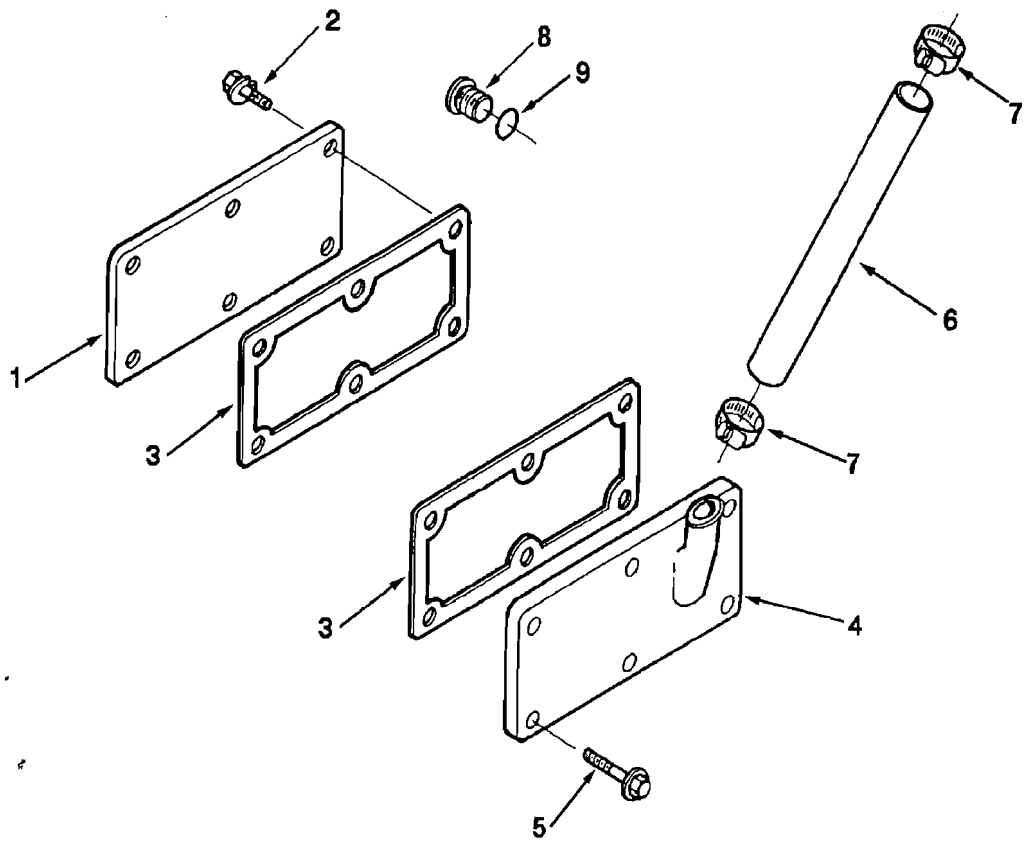

级别 LV	零件号		图上标号 Ref No	零件名称 Part Name		数量 Req	备注 Remarks
	Part Number			中文	英文		
02	3201060		1	手孔盖	COVER, HAND HOLE	2	
02	3201263		4	手孔盖	COVER, HAND HOLE	1	
02	3046202			螺塞	PLUG, THREADED	2	
03	3040810		8	螺塞	PLUG, THREADED	1	
03	3046201		9	O型密封圈	SEAL, O RING	1	
02	3201081			手孔盖安装	COVER, HAND HOLE MTG	2	
03	3010595		2	六角螺栓	SCREW, CAPTIVE WAS	6	
03	3042586		3	手孔盖衬垫	GASKET, HAND HOLE	1	
02	MP 5090			盖及支架安装	COVER & BRKT MTG	1	
03	3040838		5	带垫螺栓	SCREW, CAPTIVE WASHER CAP	6	
03	3042586		3	手孔盖衬垫	GASKET, HAND HOLE	1	
02	43828	A	7	抱箍	CLAMP, HOSE	2	
02	AS16020	NF	6	软管	HOSE, FLEXIBLE	1	

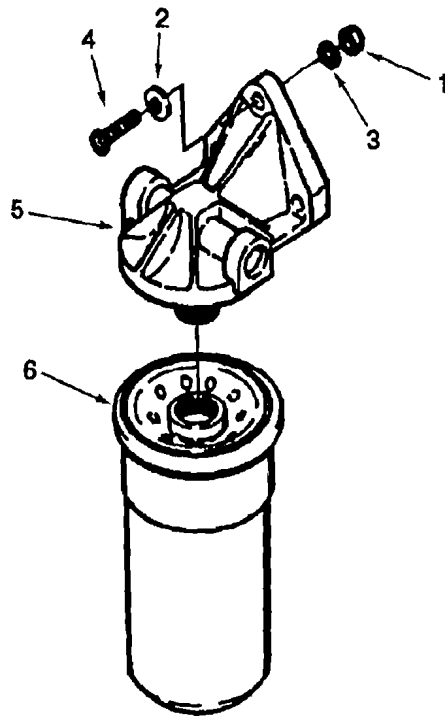

级别 LV	零件号 Part Number	图上标号 Ref No	零件名称 Part Name		数量 Req	备注 Remarks
			中文	英文		
02	3304173	5	机油滤清器座	HEAD, LUB OIL FILTER	1	
02	3889311	6	机油滤清器	ELEMENT, LUB OIL FILTER	1	
02	3035729		机油旁通滤清器安装	MTG, BYPARSS FILTER	1	
03	108707	4	六角螺栓	SCREW, HEXAGON HEAD	3	
03	S 223	1	六角厚螺母	NUT, HEAVY HEXAGON	3	
03	S 604	2	弹簧垫圈	WASHER, LOCK	3	
03	S 602	3	平垫圈	WASHER, PLAIN	6	

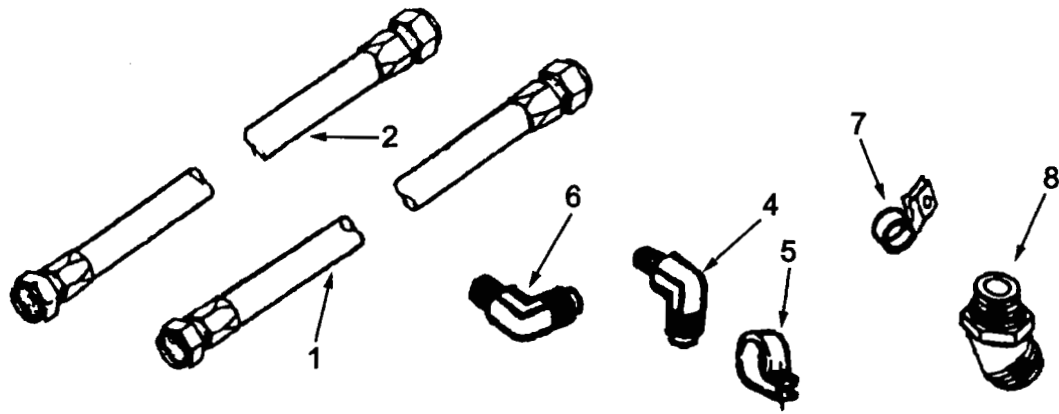

级别 LV	零件号 Part Number		图上标号 Ref No	零件名称 Part Name		数量 Req	备注 Remarks
				中文	英文		
02	3059757			旁滤器安装	MTG, BYPARSS FILTER	1	
03	68645		4	弯接头	ELBOW, MALE ADAPTER	2	
03	100269		5	夹子	CLIP	3	
03	3175687			异径三通接头	TEE, STREET PIPE	1	
03	4061143		3	阳性弯接头	ELBOW, MALE ADAPTER	1	
03	AS 6029	SS	1	软管	HOSE, FLEXIBLE	1	
03	AS 6050	SS	2	软管	HOSE, FLEXIBLE	1	
03	S 1039	A	6	接头	CONNECTOR, MALE	1	

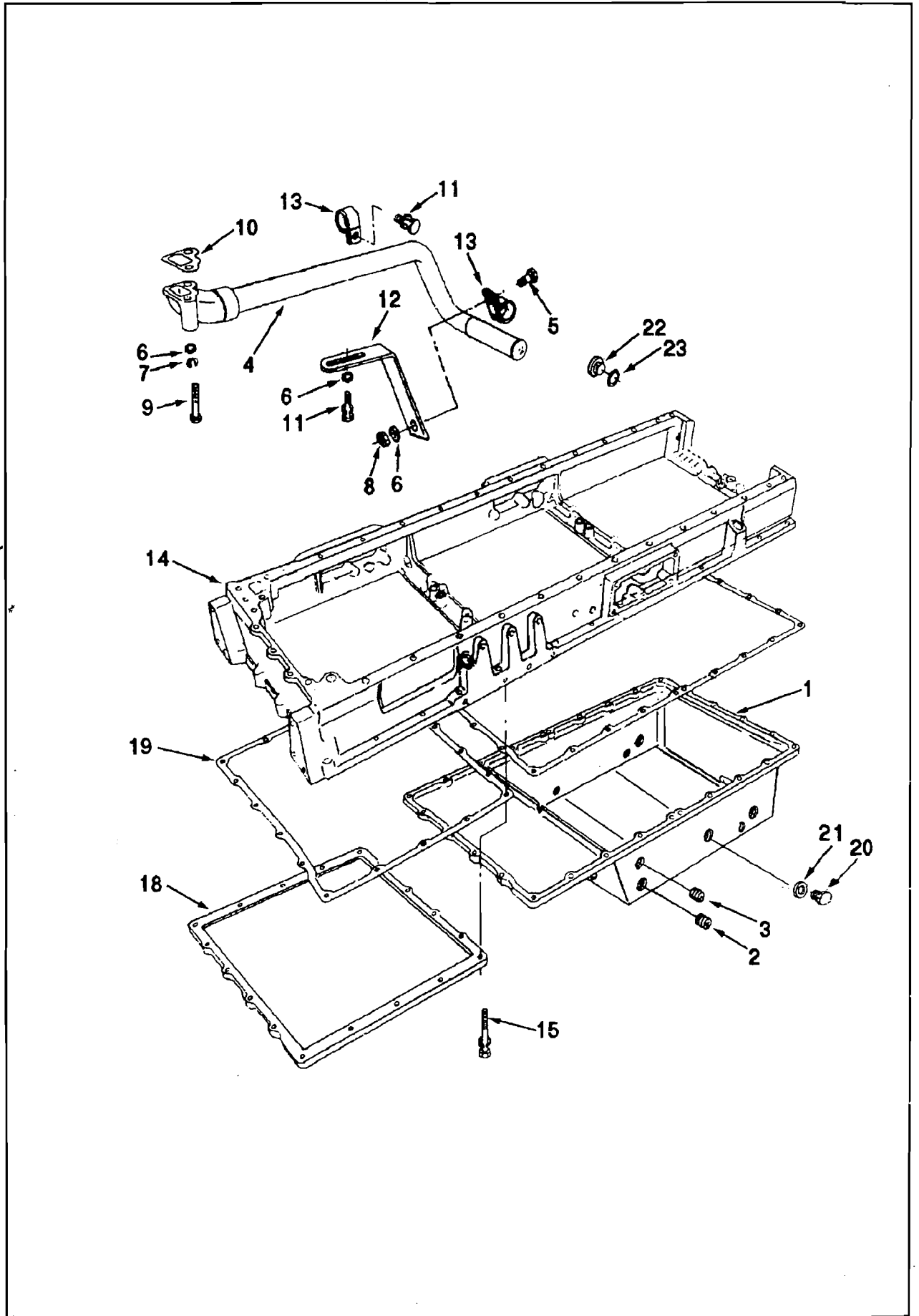

级别 LV	零件号 Part Number	图上标号 Ref No	零件名称 Part Name		数量 Req	备注 Remarks
			中文	英文		
02	3011049	4	机油吸油管	TUBE, LUB OIL SUCTION	1	
02	3012087		机油管安装	TUBE, LUB OIL	1	
03	129069	8	锁紧螺母	NUT, LOCK	1	
03	137890	9	六角螺栓	SCREW, HEXAGON HEAD CAP	2	
03	3008403	10	吸油管衬垫	GASKET, OIL SUCTION	1	
03	3010593	5	带垫螺栓	SCREW, CAPTIVE WAS	1	
03	3010595	11	带垫螺栓	SCREW, CAPTIVE WAS	2	
03	3065707	12	吸油管支架	BRACE, SUCTION CONNECTION	1	
03	3200706	13	夹箍	CLIP	2	
03	S 602	6	平垫圈	WASHER, PLAIN	4	
03	S 610	7	弹簧垫圈	WASHER, LOCK	2	
02	3418862	14	机油盘联接体	ADAPTER, OIL PAN	1	
02	AR12034		机油盘总成	PAN OIL	1	
03	3008468	2	管塞	PLUG, PIPE	2	
03	3008470	3	管塞	PLUG, PIPE	2	
03	3046942		放油塞总成	PLUG, PIPE	2	
04	3046869	22	放油塞	PLUG, THREADED	1	
04	3046943	23	O型密封圈	SEAL, O RING	1	
04	3655222		磁芯	CORE	1	
03	3202152	1	机油盘	PAN OIL	1	
02	AR10695		机油盘联接体盖	COVER, OIL PAN ADAPTER	1	
03	67946		平垫圈	WASHER, PLAIN	1	
03	207306	18	机油盘联接体盖	COVER, OIL PAN ADAPTER	1	
03	3035624	15	带垫螺栓	SCREW, CAPTIVE WASHER	18	
03	3055069		放油塞总成	PLUG, THREADED	1	
03	3073213	19	机油盘联接体盖衬垫	GASKET OIL PAN	1	
02	3000204	21	铜垫圈	WASHER, COPPER	2	
02	S 181 C	20	六角螺栓	SCREW, HEXAGON HEAD CAP	2	

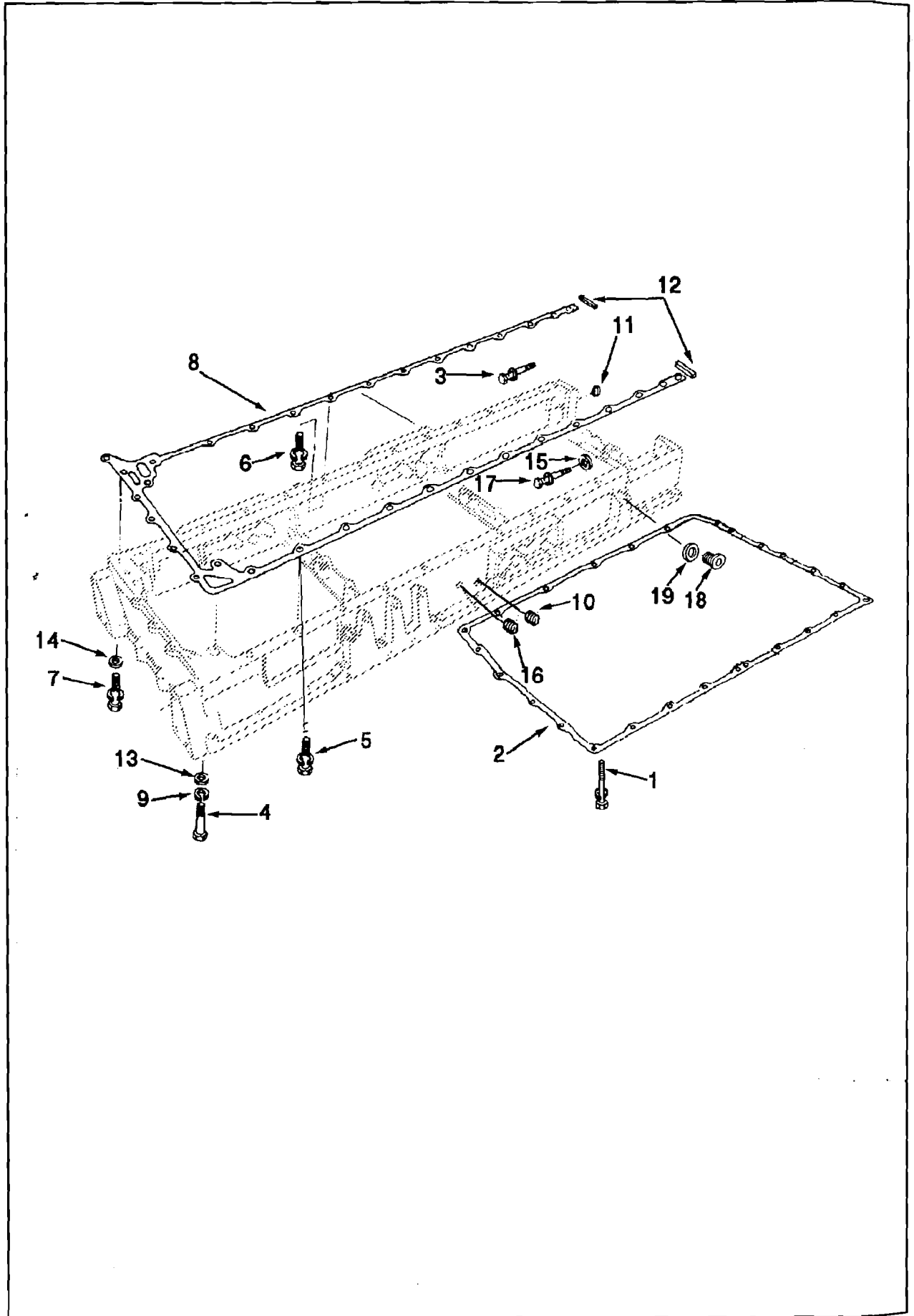

表一46

机油盘安装 Mtg, Oil Pan

OP 4716

级别 LV	零件号 Part Number	图上标号 Ref No	零件名称 Part Name		数量 Req	备注 Remarks
			中文	英文		
02	3016725		机油盘联接体安装	MTG, OIL PAN ADAPT	1	
03	127362	14	平垫圈	WASHER, PLAIN	2	
03	137980	4	六角螺栓	SCREW, HEXAGON HEAD CAP	1	
03	153518	11	矩型密封圈	SEAL, RECTANGULAR	4	
03	3040837	7	带垫螺栓	SCREW, CAPTIVE WAS	1	
03	3012478	5	带垫螺栓	SCREW, CAPTIVE WASHER	2	
03	3012481	17	六角螺栓	SCREW, HEXAGON HEAD	2	
03	3013786	16	管塞	PLUG, PIPE	1	
03	3025460	10	管塞	PLUG, PIPE	1	
03	3065723	6	带垫螺栓	SCREW, CAPTIVE WASHER	28	
03	3035624	3	带垫螺栓	SCREW, CAPTIVE WASHER	5	
03	3046202		螺塞	PLUG, THREADED	2	
04	3040810	18	螺塞	PLUG, THREADED	1	
04	3046201	19	O型圈	SEAL, O RING	1	
03	3069844	12	矩型带	SEAL, RECTANGULAR STRIP	2	
03	4000595	8	机油盘连接体衬垫	GASKET, OIL PAN	1	
03	S 609	9	弹簧垫圈	WASHER, LOCK	1	
03	S 622	15	平垫圈	WASHER, PLAIN	2	
03	S 689	13	平垫圈	WASHER, PLAIN	1	
02	MP 5012		机油盘安装总成	PAN, OIL MTG	1	
03	3035624	1	带垫螺栓	SCREW, CAPTIVE WASHER	28	
03	3042590	2	机油盘衬垫	GASKET, OIL PAN	1	

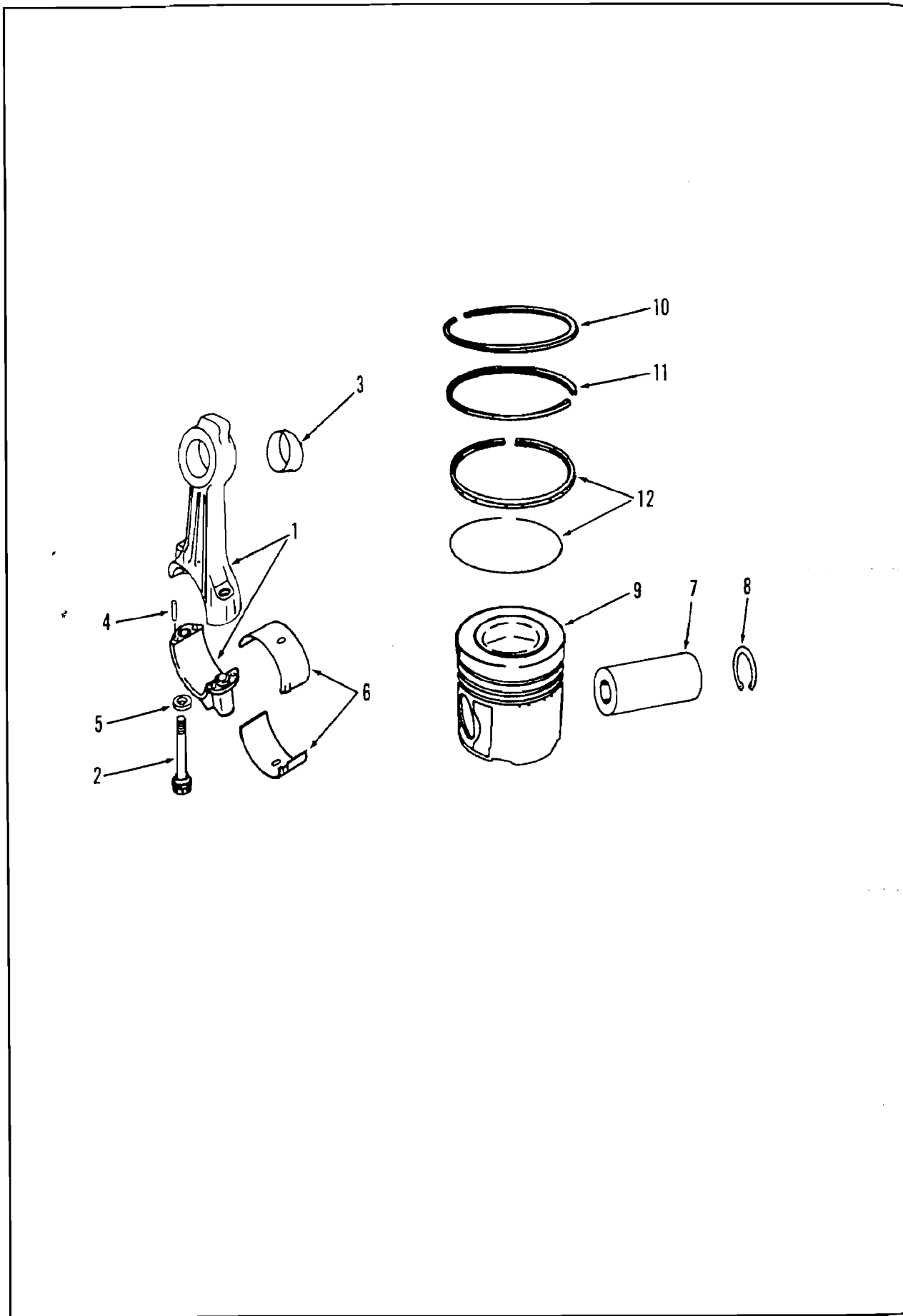

级别 LV	零件号 Part Number	图上标号 Ref No	零件名称 Part Name		数量 Req	备注 Remarks
			中文	英文		
02	3039218		活塞连杆总成	PISTON & CONN ROD	6	适用于:
03	205200	7	活塞销	PIN, PISTON	1	KTA19-G2(M)
03	205269	8	挡圈	RING, RETAININGT	2	
03	205840	6	连杆瓦	BEARINGT, CONNECTING ROD	2	
03	3036073	9	活塞	PISTON, ENGINE	1	
03	3070589	10	压缩环	RING, COMPRESSION PISTON	1	
03	3090450	12	油环	RING OIL PISTON	1	
03	3090460	11	压缩环	RING, COMPRESSION PISTON	1	
03	3811995		发动机连杆	ROD, ENGINE CONNECTING	1	
04	69558	4	定位销	DOWEL, PIN	4	
04	205126	5	平垫圈	WASHER, PLAIN	2	
04	3013265	2	连杆螺栓	SCREW, CONNECTING ROD CAP	2	
04	3043909	3	衬套	BUSHING	1	
04	3811994	1	连杆	ROD, ENGINE CONNECT	1	
03	205841	6	连杆瓦	BEARINGT CONNECTINGROD	2	加厚.001英寸
03	205842	6	连杆瓦	BEARINGT CONNECTINGROD	2	加厚.002英寸
03	205843	6	连杆瓦	BEARINGT CONNECTINGROD	2	加厚.003英寸

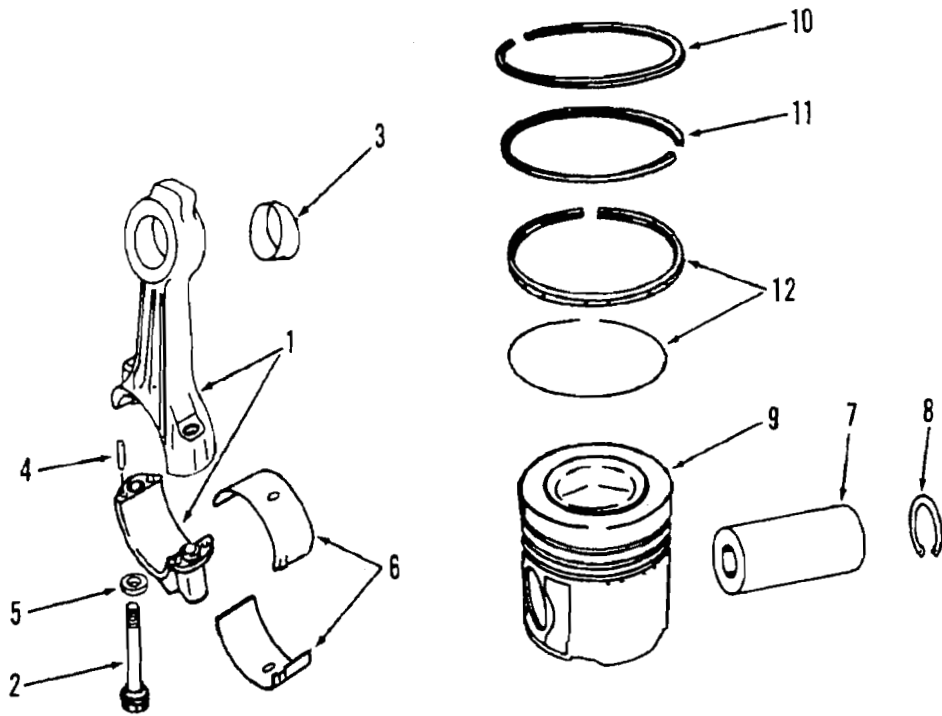

表—48

活塞和连杆 Piston And Connrod

PP 1456、PP 4152

级别 LV	零件号 Part Number	图上标号 Ref No	零件名称 Part Name		数量 Req	备注 Remarks
			中文	英文		
02	3062598		活塞连杆总成	PISTON & CONN ROD	6	适用于:
03	205200	7	活塞销	PIN, PISTON	1	KTA19-G3(M)
03	205269	8	挡圈	RING, RETAININGT	2	/G4(M)
03	205840	6	连杆瓦	BEARINGT, CONNECTING ROD	2	
03	3070589	10	压缩环	RING, COMPRESSION PISTON	1	
03	3090450	12	油环	RING, OIL PISTON	1	
03	3090460	11	压缩环	RING, CPMPRESSION PISTON	1	
03	3096685	9	活塞	PISTON, ENGINE	1	
03	3811995		发动机连杆	ROD, ENGINE CONNECTING	1	
04	69558	4	定位销	DOWEL, PIN	4	
04	205126	5	平垫圈	WASHER, PLAIN	2	
04	3013265	2	连杆螺栓	SCREW, CONNECTING ROD CAP	2	
04	3043909	3	衬套	BUSHING	1	
04	3811994	1	连杆	ROP, ENGIN CONNEC	1	
03	205841	6	连杆瓦	BEARINGT, CONNECTING ROD	2	加厚0.01英寸
03	205842	6	连杆瓦	BEARINGT, CONNECTING ROD	2	加厚0.02英寸
03	205843	6	连杆瓦	BEARINGT, CONNECTING ROD	2	加厚0.03英寸

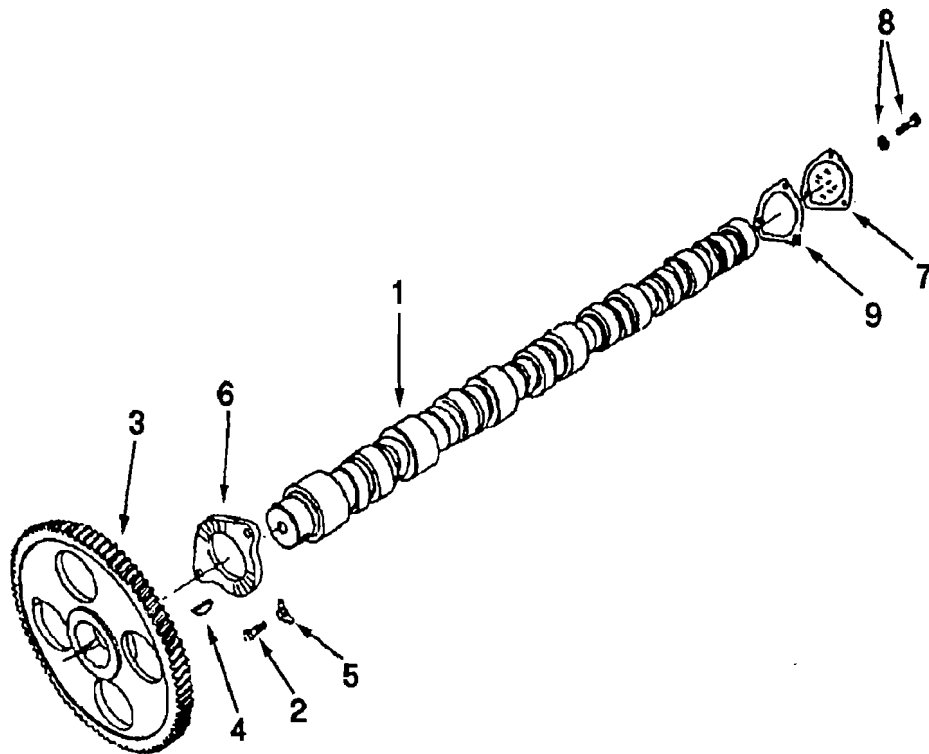

级别 LV	零件号 Part Number	图上标号 Ref No	零件名称 Part Name		数量 Req	备注 Remarks
			中文	英文		
02	3028960		凸轮轴	CAMSHAFT	1	适用于: KTA19-G2(M)
03	200708	4	半圆键	KEY, OFFSET WOODRUFF	1	
03	207770	1	凸轮轴	CAMSHAFT	1	
03	3007971	6	凸轮轴止推轴承	BEARING, CAMSHAFT THRUST	1	
03	3008970	3	凸轮轴齿轮	GEAR, CAMSHAFT	1	
02	MP 4970		凸轮轴安装	CAMSHAFT, MTG	1	
03	68908	5	螺栓锁紧片	LOCK PLANE CAPSCREW	2	
03	S 112	2	螺栓	SCREW, HEXAGON HEAD CAP	2	
02	207373	7	凸轮轴端盖	COVER, CAMSHAFT	1	
02	MP 4981		凸轮轴盖安装	COVER CAMSHAFT MTG	1	
03	3014766	8	带垫螺栓	SCREW, CAPTIVE WASHER CAP	3	
03	3040722	9	凸轮轴盖衬垫	GASKET, CAMSHAFT COVER	1	

级
I

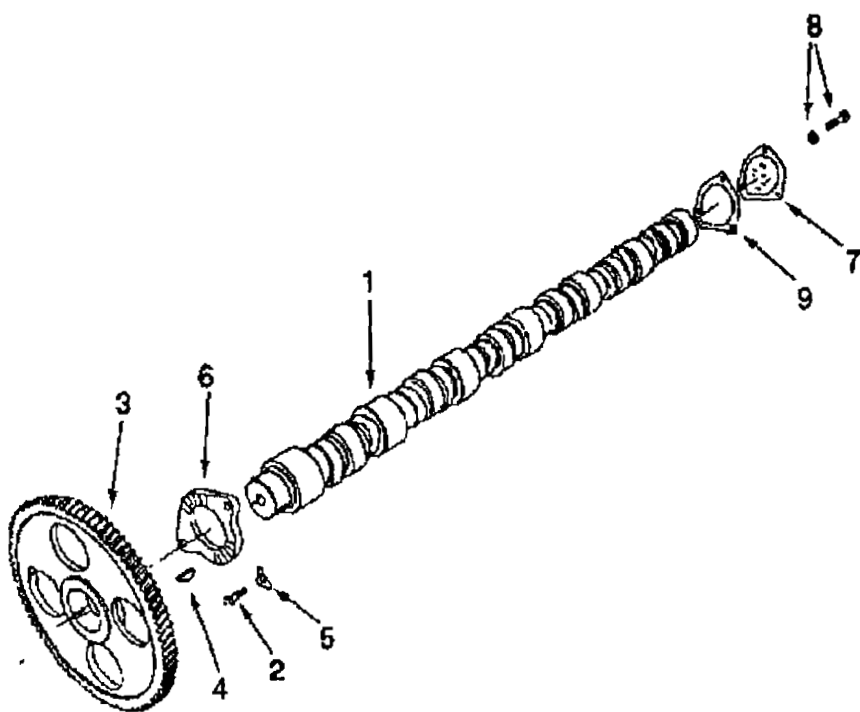

级别 LV	零件号 Part Number	图上标号 Ref No	零件名称 Part Name		数量 Req	备注 Remarks
			中文	英文		
02	3073207		凸轮轴	CAMSHAFT	1	适用于: KTA19-G3(M)
03	200709	4	半圆键	KEY, OFFSET WOODRUFF	1	
03	3066882	1	凸轮轴	CAMSHAFT	1	
03	3007971	6	凸轮轴止推轴承	BEARING, CAMSHAFT THRUST	1	
03	3008970	3	凸轮轴齿轮	GEAR, CAMSHAFT	1	
02	MP 4970		凸轮轴安装	CAMSHAFT, MTG	1	
03	68908	5	螺栓锁紧片	LOCK PLANE CAPSCREW	2	
03	S 112	2	螺栓	SCREW, HEXAGON HEAD CAP	2	
02	207373	7	凸轮轴端盖	COVER, CAMSHAFT	1	
02	MP 4981		凸轮轴盖安装	COVER CAMSHAFT MTG	1	
03	3014766	8	带垫螺栓	SCREW, CAPTIVE WASHER CAP	3	
03	3040722	9	凸轮轴盖衬垫	GASKET, CAMSHAFT COVER	1	

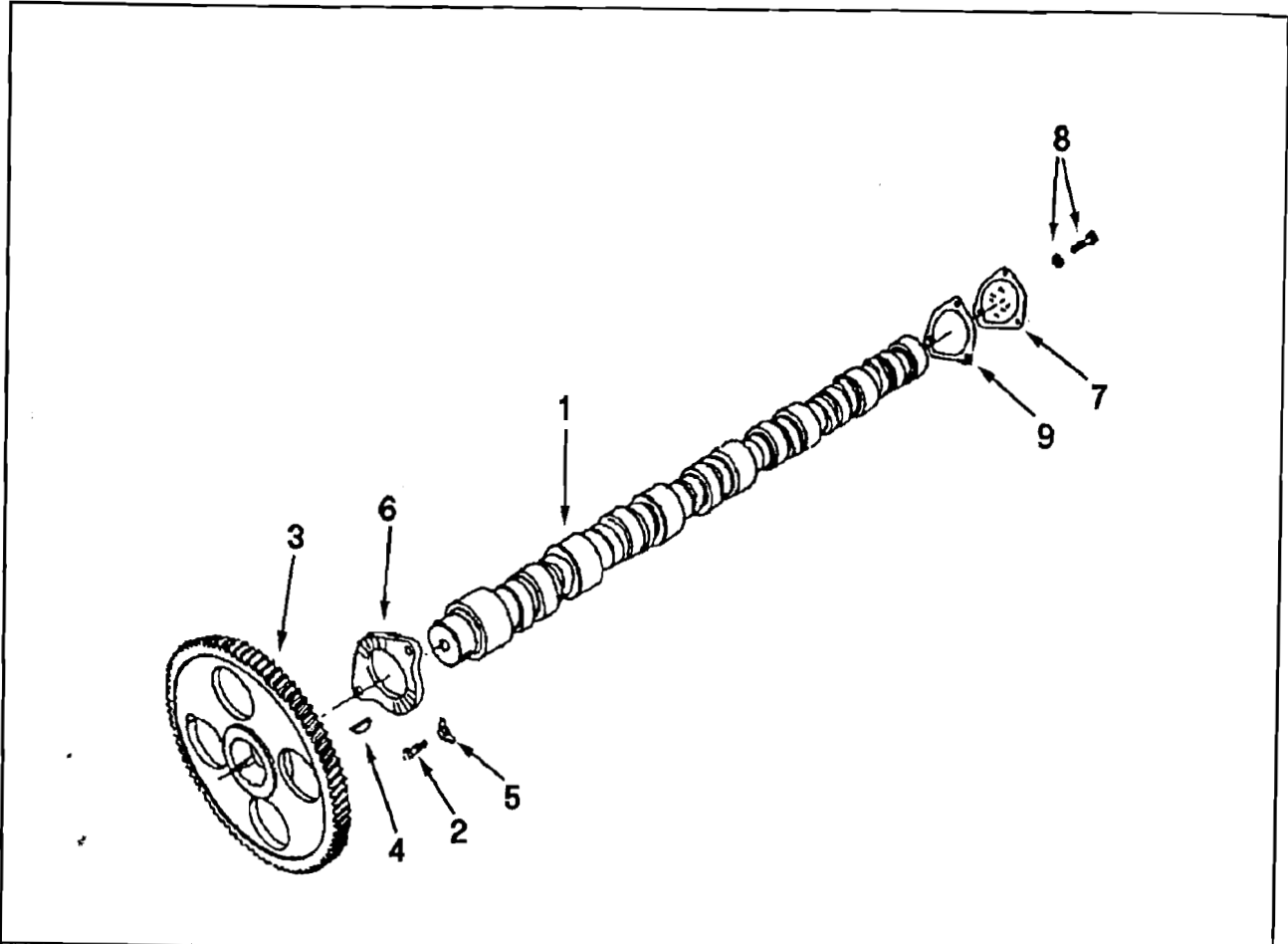

级别 LV	零件号 Part Number	图上标号 Ref No	零件名称 Part Name		数量 Req	备注 Remarks
			中文	英文		
02	3088590		凸轮轴	CAMSHAFT	1	适用于: KTA19-G4(M)
03	216294	4	半圆键	KEY, OFFSET	1	
03	3007971	6	凸轮轴止推轴承	BEARING, CAMSHAFT THRUST	1	
03	3008970	3	凸轮轴齿轮	GEAR, CAMSHAFT	1	
03	3076767	1	凸轮轴	CAMSHAFT	1	
02	MP 4970		凸轮轴安装	CAMSHAFT, MTG	1	
03	68908	5	螺栓锁紧片	LOCK PLANE CAPSCREW	2	
03	S 112	2	螺栓	SCREW, HEXAGON HEAD CAP	2	
02	207373	7	凸轮轴端盖	COVER, CAMSHAFT	1	
02	MP 4981		凸轮轴盖安装	COVER CAMSHAFT MTG	1	
03	3014766	8	带垫螺栓	SCREW, CAPTIVE WASHER CAP	3	
03	3040722	9	凸轮轴盖衬垫	GASKET, CAMSHAFT COVER	1	

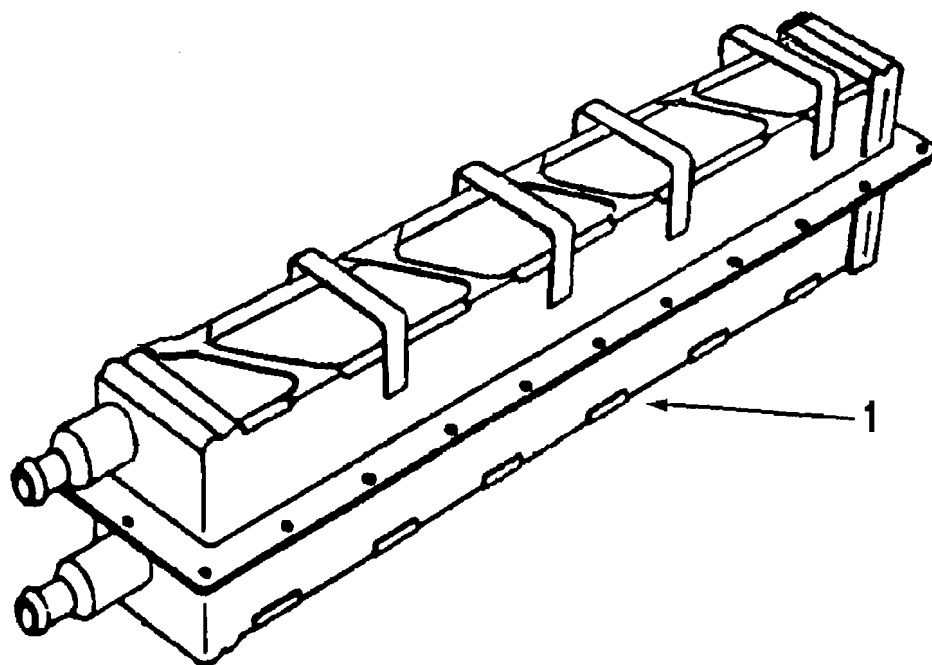

级别 LV	零件号 Part Number	图上标号 Ref No	零件名称 Part Name		数量 Req	备注 Remarks
			中文	英文		
02	3001299	1	中冷器芯	CORE, AFTER COOLER	1	

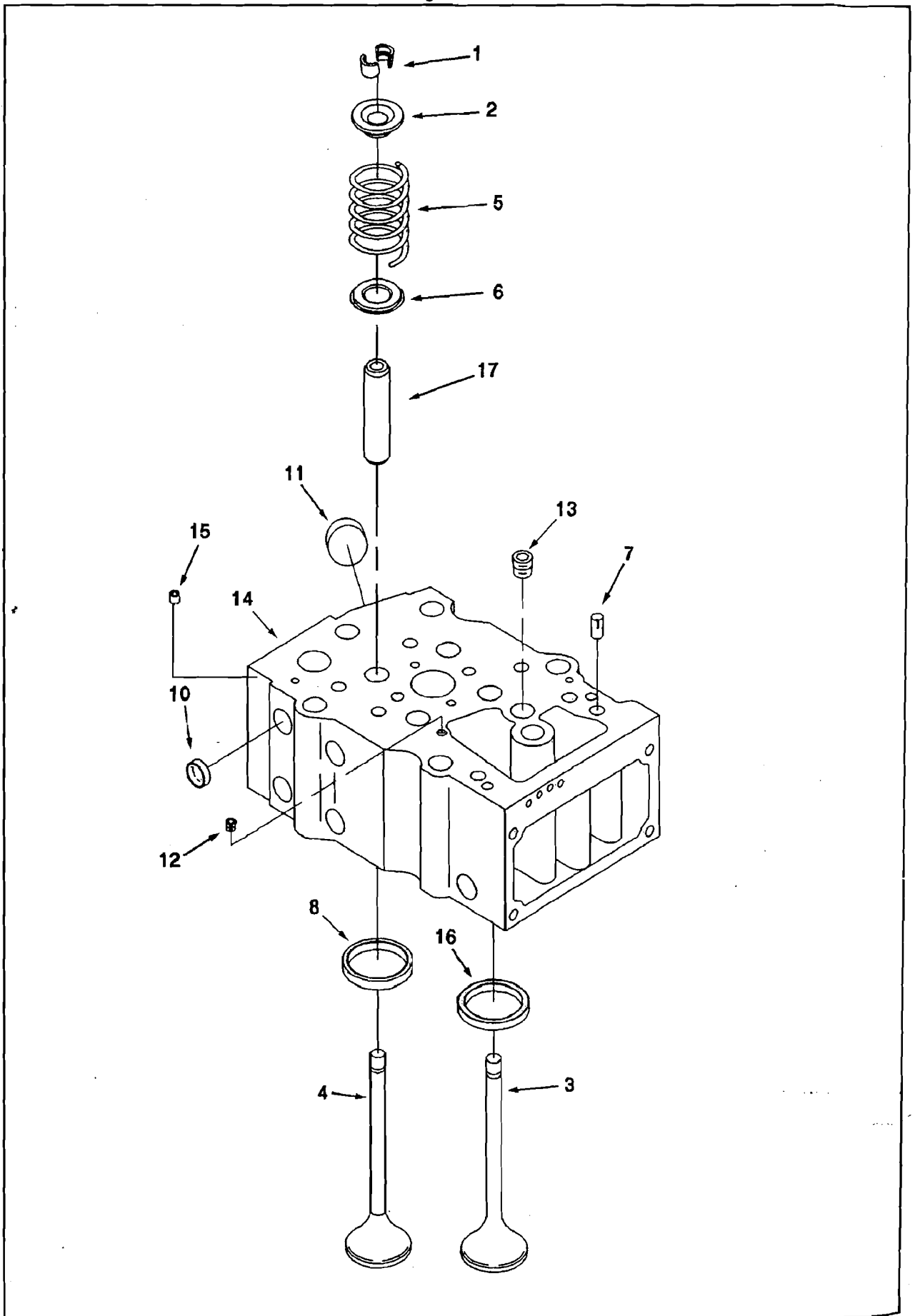

级别 LV	零件号 Part Number	图上标号 Ref No	零件名称 Part Name		数量 Req	备注 Remarks
			中文	英文		
02	3021692		气缸盖	HEAD, CYLINDER	6	适用于:
03	205091	1	气门锁夹	COLOLET, VALVE	8	KTA19-G2(M)
03	205094	2	气门弹簧上座	RETAINER, VALVE SPRING	4	
03	205208	5	气门弹簧	SPRING, VALVE	4	
03	207241	3	进气门	VALVE, INTAKE	2	
03	3001663	6	气门弹簧下座板	GUIDE, VALVE SPRING	4	
03	3035110	4	排气门	VALVE, EXHAUST	2	
03	3037214		缸盖	HEAD, CYLINDER	1	
04	68445	7	带槽圆柱销	PIN, GROOVE	2	
04	205093	8	排气门镶座	INSERT, VALVE	2	
04	3009089		气缸盖	HEAD, CYLINDER	1	
05	205401	10	碗型塞	PLUG, EXPANSION	8	
05	206224	11	碗型塞	PLUG, EXPANSION	2	
05	S 911	B 12	管塞	PLUG, PIPE	1	
05	3013257	13	管塞	PLUG, PIPE	1	
05	3176619	14	气缸盖	HEAD, CYLINDER	1	
04	3009109		空气偏浇板	PLATE, AIR DEFLEC	2	
04	3026292	16	进气门镶座	INSERT, VALVE	2	
04	3201311	17	气门导管	GUIDE, VALVE STEM	4	

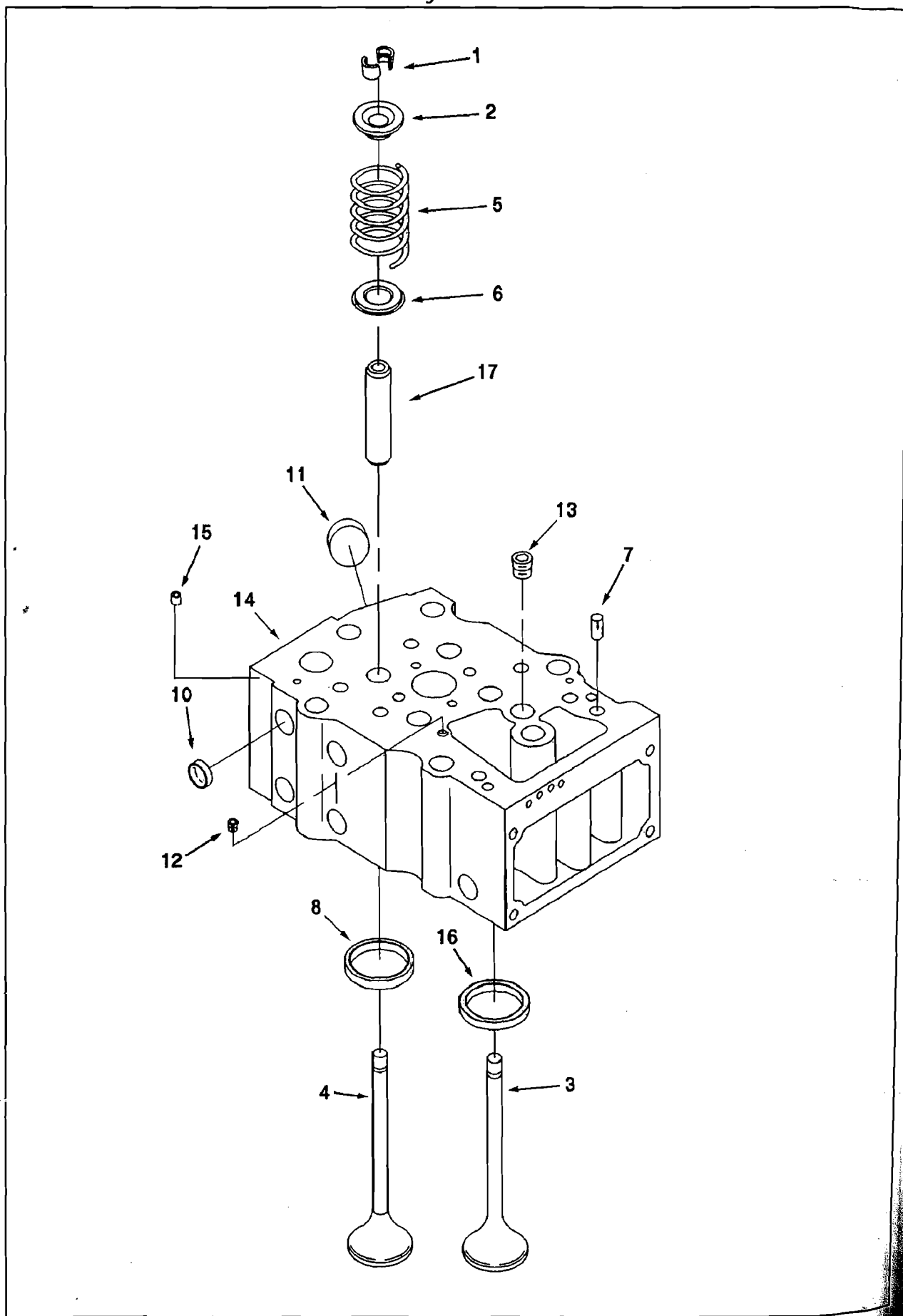

级别 LV	零件号 Part Number	图上标号 Ref No	零件名称 Part Name		数量 Req	备注 Remarks
			中文	英文		
02	3811985		气缸盖	HEAD, CYLINDER	6	适用于:
03	205091	1	气门锁夹	COLLET, VALVE	8	KTA19-G3(M)
03	205094	2	气门弹簧上座	RETAINER, VALVE SPRING	4	/G4(M)
03	3052820	3	进气门	VALVE, INTAKE	2	
03	3081081	6	气门转子	ROTATER	4	
03	3088389	4	排气门	VALVE, EXHAUST	2	
03	3633840	5	气门弹簧	SPRING, VALVE	4	
03	3811981		气缸盖	HEAD, CYLINDER	1	
04	68445	7	带槽圆柱销	PIN, GROOVE	2	
04	205093	8	排气门镶座	INSERT, VALVE	2	
04	3052819	16	气门座圈	INSERT, VALVE	2	
04	3081065		气缸盖	HEAD, CYLINDER	1	
05	3013786	12	管塞	PLUG, PIPE	1	
05	203933	15	碗型塞	PLUG, EXPANSION	1	
05	205401	10	碗型塞	PLUG, EXPANSION	8	
05	206224	11	碗型塞	PLUG, EXPANSION	2	
05	3081064	14	气缸盖	HEAD, CYLINDER	1	
05	3201311	17	气门导管	GUIDE, VALVE STEM	4	
05	S 915	13	管塞	PLUG, PIPE	1	

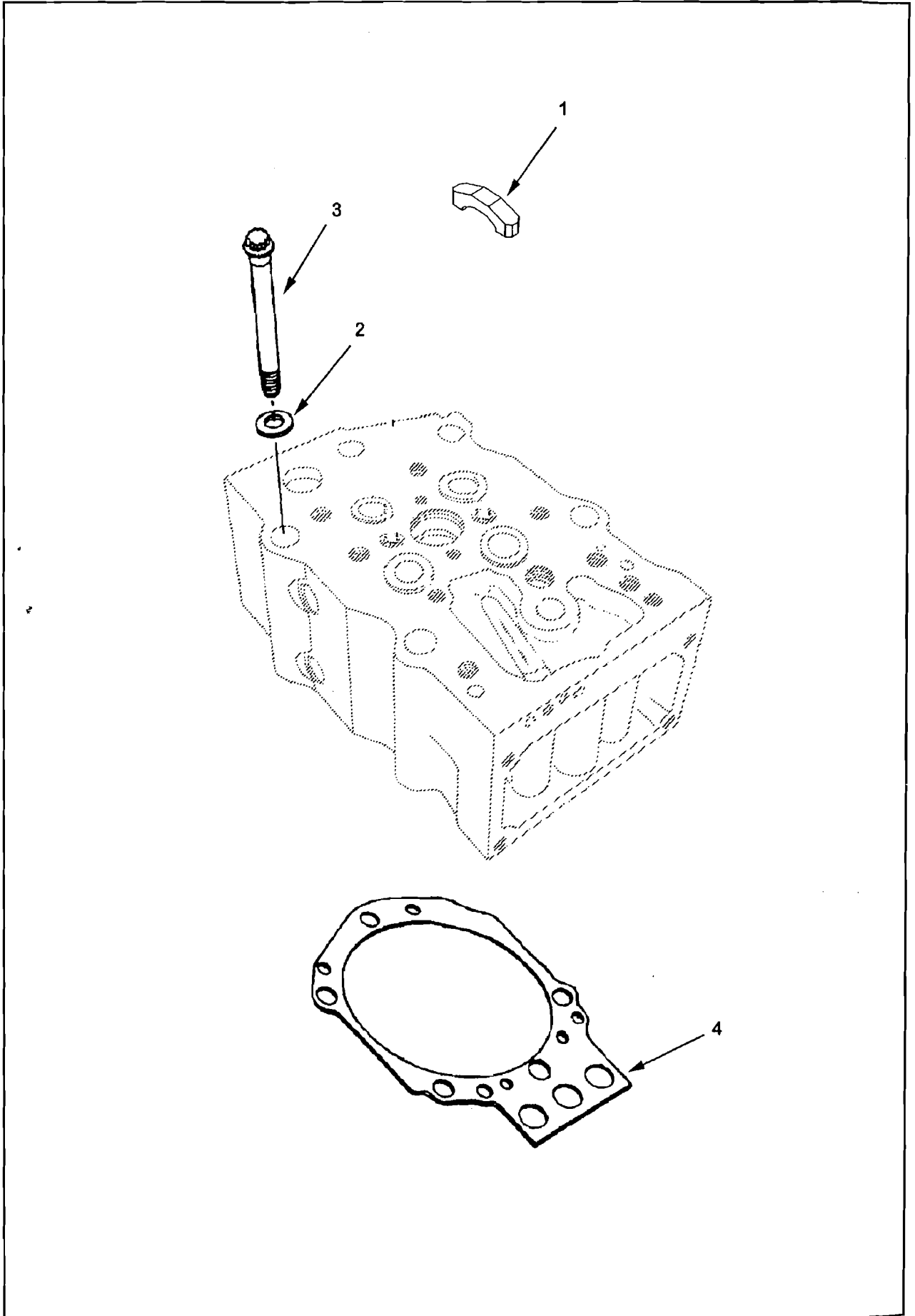

表—55

气缸盖安装 Mtg, Cylinder Head PP 4107.PP 1456.PP 4152

级别 LV	零件号 Part Number	图上标号 Ref No	零件名称 Part Name		数量 Req	备注 Remarks
			中文	英文		
02	3013962		气缸盖安装	HEAD, CYLINDER MTG	6	
03	205059	2	平垫圈	WASHER, CYLINDER	6	
03	3032633	3	十二角螺栓	SCREW, TWELVE POINT CAP	6	
03	3086362	1	丁字压板	CROSSHEAD, VALVE	2	
02	3166289	4	气缸垫	GASKET, CYLINDER H	6	

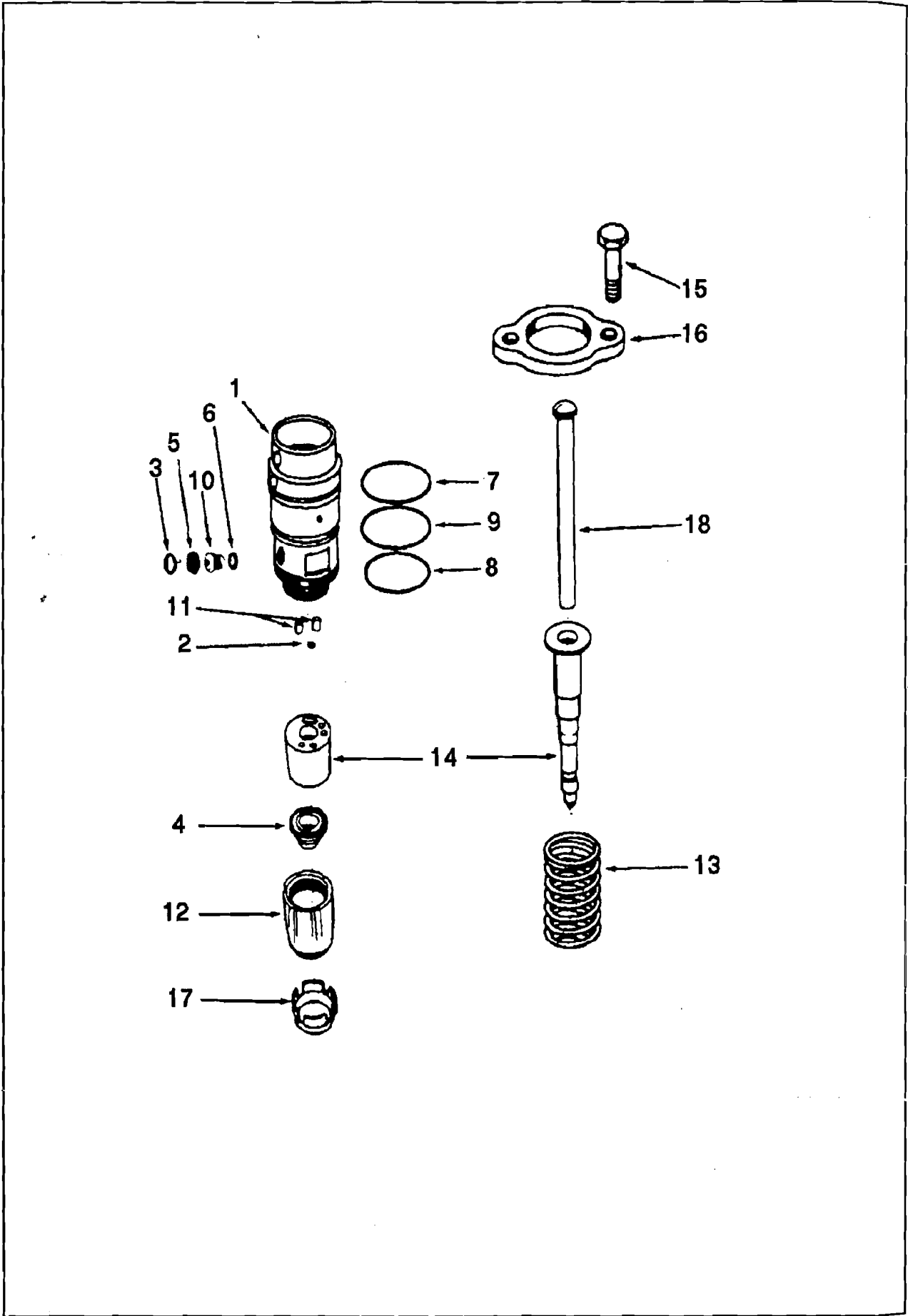

表—56

喷油器 Injector

PP 4107

级别 LV	零件号 Part Number	图上标号 Ref No	零件名称 Part Name		数量 Req	备注 Remarks
			中文	英文		
02	3016676		喷油器	INJECTOR	6	适用于: KTA19-G2(M)
	167157	2	止回球阀	BALL, CHECK	1	
	173086	6	衬垫	GASKET, INJECTOR	1	
	174299	3	挡板	RETAINER, SCREEN	1	
	193736	8	O型密封圈	SEAL, O RING	3	
	203426	11	圆柱销	PIN, ROLL	2	
	205463	1	喷油器体	ADAPTER, INJECTOR	1	
	205464	13	压缩弹簧	SPRING, COMPRESSION	1	
	207245	12	螺帽	RETAINER, INJECTOR CUP	1	
	3001314	4	喷油器油环	CUP, INJECTOR	1	
	3008706	5	过滤板	SCREEN, FILTER	1	
	3037292	14	柱塞副总成	BARREL & PLUNGER	1	
	3045047	10	堵塞	PLUG, INJECTOR ORIFICE	1	
02	MR 4991		喷油嘴安装	INJECTOR, MTG	6	
03	165006	15	六角螺栓	SCREW, HEXAGON HEAD	2	
03	205462	18	喷油器连接杆	LINK, INJECTOR PL	1	
03	207244	17	喷油器密封环	RING, INJECTOR SE	1	
03	3006696	16	喷油器压板	CLAMP, INJECTOR	1	

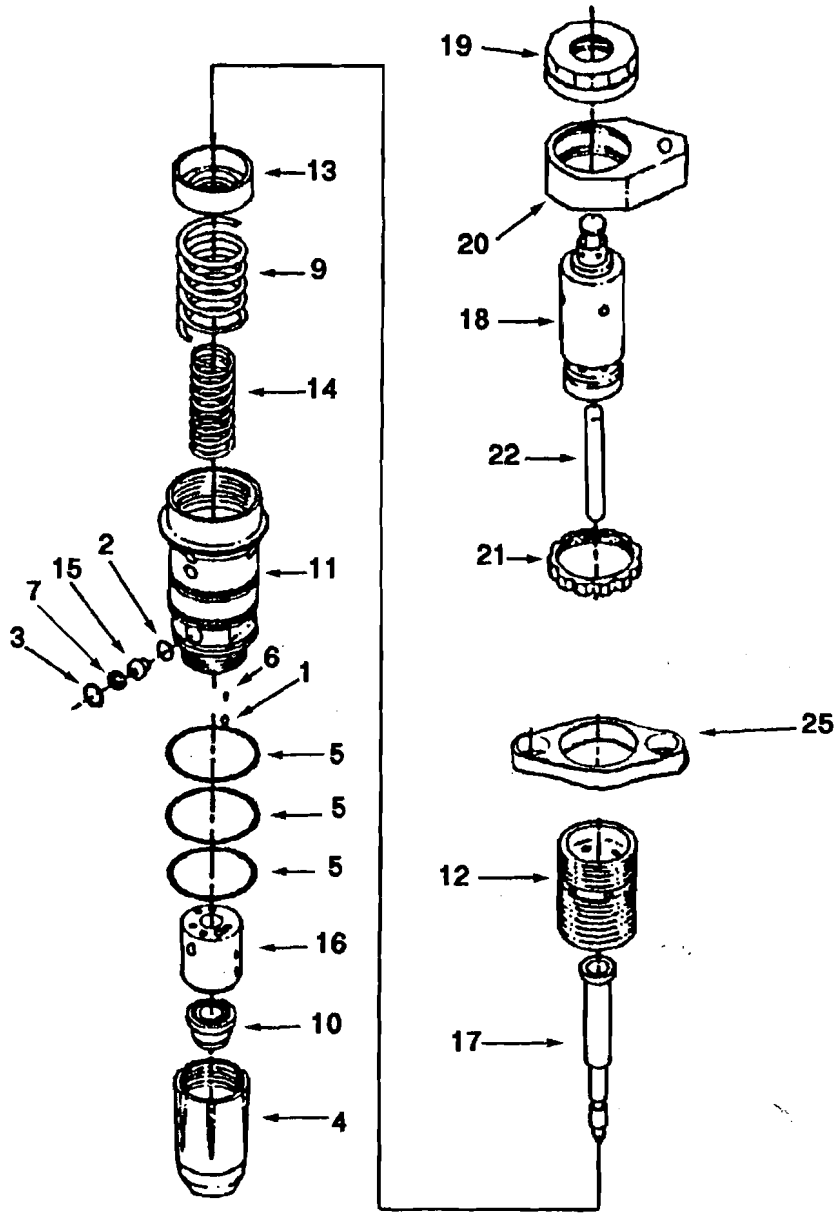

级别 LV	零件号 Part Number	图上标号 Ref No	零件名称 Part Name		数量 Req	备注 Remarks
			中文	英文		
02	3077715		喷油器	INJECTOR	6	总成装配已
	167157	1	止回球阀	BALL, CHECK	1	适用于:
	173086	2	衬垫	GASKET, INJECTOR	1	KTA19-G3 (M)
	174299	3	挡板	RETAINER, SCREEN	1	
	193736	5	O型密封圈	SEAL, O RING	3	
	203426	6	圆柱销	PIN, ROLL	2	
	3042425	11	喷油器体	ADAPTER, INJECTOR	1	
	3042427	14	喷油器弹簧	SPRING, INJECTOR	1	
	3042428	9	喷油器弹簧	SPRING, INJECTOR	1	
	3042430	4	螺帽	RETAINER, INJECTOR CUP	1	
	3045047	15	堵塞	PLUG, INJECTOR ORIFICE	1	
	3052218	13	弹簧螺帽	RETAINER, INJECTOR SPR	1	
	3054999	7	过滤板	SCREEN, FILTER	1	
	3068859	19	喷油器顶帽	CAP, TAPPET TOP STOP	1	
	3075381	18	HVT挺杆	TAPPET, HYD VAR TIMING	1	
	3076126		柱塞副总成	BARREL & PLUNGER	1	
	(3053504)	16	柱塞套	BARREL, INJECTOR	1	
	(3076124)	17	柱塞	PLUNGER, INJECTOR	1	
	3279720	10	喷油器帽	CUP, INJECTOR	1	
	3279821	12	螺栓	SCREW, INJECTOR STOP	1	
	3279850	20	锁紧螺母	NUT, TAPPET TOP STOP LOC	1	
	3411695	25	喷油器压板	CLAMP, INJECTOR	1	
	3627894	22	喷油器连接杆	LINK, INJECTOR PLUNGER	1	
	3068860	21	锁紧螺母	NUT, LOCK	1	
02	3073205		喷油嘴安装	INJECTOR MTG.	6	
03	131026	25	O型密封圈	SEAL, O RING	1	
03	207244	24	喷油器密封环	SEAL, INJECTOR	1	
03	3023095	27	垫圈	WASHER, SEALING	2	
03	3070962	23	六角螺栓	SCREW, HEXAGON HEAD CAP	2	
03	3179021	26	螺栓	SCREW, BANJO CONNECTOR	1	
03	3627044	28	HVT机油输油管	CONNECTION, OIL TRANSFER	1	

级别 LV	零件号 Part Number	图上标号 Ref No	零件名称 Part Name		数量 Req	备注 Remarks
			中文	英文		
02	3095773		喷油器	INJECTOR	6	总成装配
	167157	1	止回球阀	BALL, CHECK	1	适用于:
	173086	2	衬垫	GASKET, INJECTOR	1	KTA19-G4(M)
	174299	3	挡板	RETAINER, SCREEN	1	
	193736	5	O型密封圈	SEAL, O RING	3	
	203426	6	圆柱销	PIN, ROLL	2	
	3042425	11	喷油器体	ADAPTER, INJECTOR	1	
	3042427	14	喷油器弹簧	SPRING, INJECTOR	1	
	3042428	9	喷油器弹簧	SPRING, INJECTOR	1	
	3042430	4	螺帽	RETAINER, INJECTOR CUP	1	
	3045047	15	堵塞	PLUG, INJECTOR ORIFICE	1	
	3052218	13	弹簧螺帽	RETAINER, INJECTOR SPR	1	
	3054999	7	过滤板	SCREEN, FILTER	1	
	3068859	19	喷油器顶帽	CAP, TAPPET TOP STOP	1	
	3075381	18	HVT挺杆	TAPPET, HYD VAR TIMING	1	
	3076126		柱塞副总成	BARREL & PLUNGER	1	
	(3053504)	16	柱塞套	BARREL, INJECTOR	1	
	(3076124)	17	柱塞	PLUNGER, INJECTOR	1	
	3279720	10	喷油器帽	CUP, INJECTOR	1	
	3279821	12	螺栓	SCREW, INJECTOR STOP	1	
	3279850	20	锁紧螺母	NUT, TAPPET TOP STOP LOC	1	
	3411695	22	喷油器压板	CLAMP, INJECTOR	1	
	3627894	21	喷油器连接杆	LINK, INJECTOR PLUNGER	1	
02	3073205		喷油嘴安装	INJECTOR MTG.	6	
03	131026	25	O型密封圈	SEAL, O RING	1	
03	207244	24	喷油器密封环	SEAL, INJECTOR	1	
03	3023095	27	垫圈	WASHER, SEALING	2	
03	3070962	23	六角螺栓	SCREW, HEXAGON HEAD CAP	2	
03	3179021	26	螺栓	SCREW, BANJO CONNECTOR	1	
03	3627044	28	HVT机油输油管	CONNECTION, OIL TRANSFER	1	

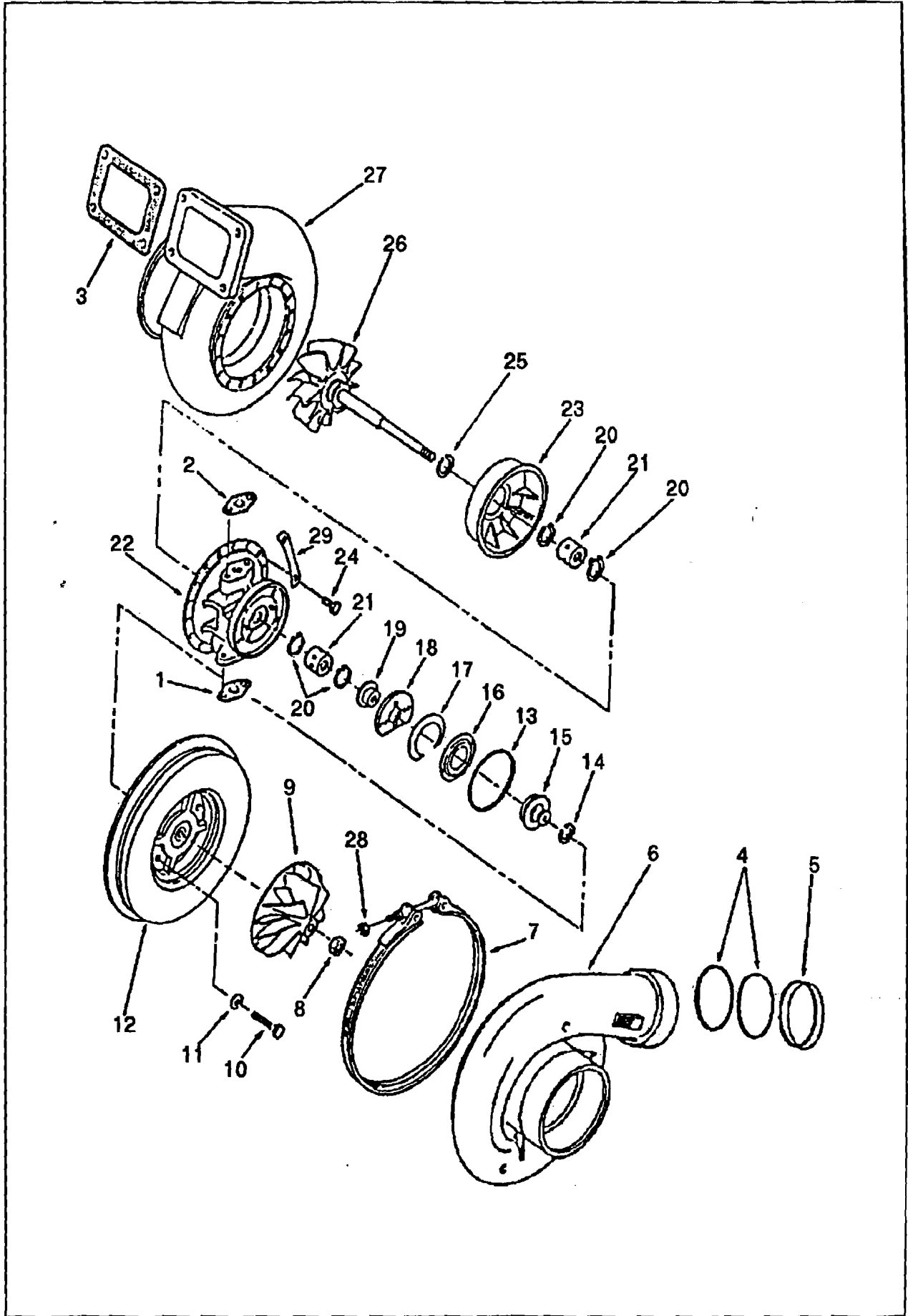

表—59

增压器 Turbocharger

PP 4107

级别 LV	零件号 Part Number	图上标号 Ref No	零件名称 Part Name		数量 Req	备注 Remarks
			中文	英文		
02	3523851		增压器	TURBOCHARGER	1	总成装配 适用于:
	3502449	1	矩形密封圈	SEAL, RECTANGULAR RING	1	KTA19-G2(M)
	3504967	2	平垫圈	WASHER, PLAIN	4	
	3519163	3	自攻螺栓	SCREW, DRIVE	2	
	3519135	4	锁紧螺母	NUT, LOCK	1	
	3519623	5	止推环	COLLER, THRUST	1	
	3519627	6	轴承	BEARING, TURBOCHARGER	2	
	3519641	7	挡圈	RING, RETAINING	4	
	3519783	8	隔热板	SHIELD, TURBOCHARGER	1	
	3521225	9	六角螺栓	SCREW, HEXAGON HEAD SET	8	
	3521442	10	密封环	SEAL, SPLIT RING	1	
	3522631	11	V型带卡	GLAMP, V BAND	1	
	3522094	12	锁片	LOCKPLATE	4	
	3523412	13	密封环	SEAL, SPLIT RING	1	
	3523429	14	轴承壳	HOUSING, TUR BEARING	1	
	3523980	15	抛油环	SINGER, OIL	1	
	3524418	16	调整垫片	SHIM	1	
	3524419	17	挡油板	BAFFLE, HEXAGON HEAD SET	1	
	3525073	18	六角螺栓	SCREW, HEXAGON HEAD SET	4	
	3521033	19	轴和涡轮	SHAFT & WHEEL	1	
	3526985	20	止推轴承	BEARING, TUR THRUST	1	
	3524862	21	扩压板	DIFFUSER, TURBOCHARGER	1	
	3524861	22	压气机壳	HOUSING, COMPRESSOR	1	
	3521918	23	叶轮	IMPELLER, TUR COMPRESSURE	1	
	3527619	24	铭牌	DATAPLATE	1	
	3529372	25	六角螺母	NUT, REGULAR HEXAGON	1	
	3534201	26	涡壳	HOUSING, TURBINE	1	
	3522904	29	锁紧片	LOCKPLATE	1	
	3523412	14	密封圈	SEAL, SPLIT RING	1	
	3520933	22	轴承套	HOUSING, TUR BEARING	1	
	3522597		滚轮销	PIN, ROLL	2	

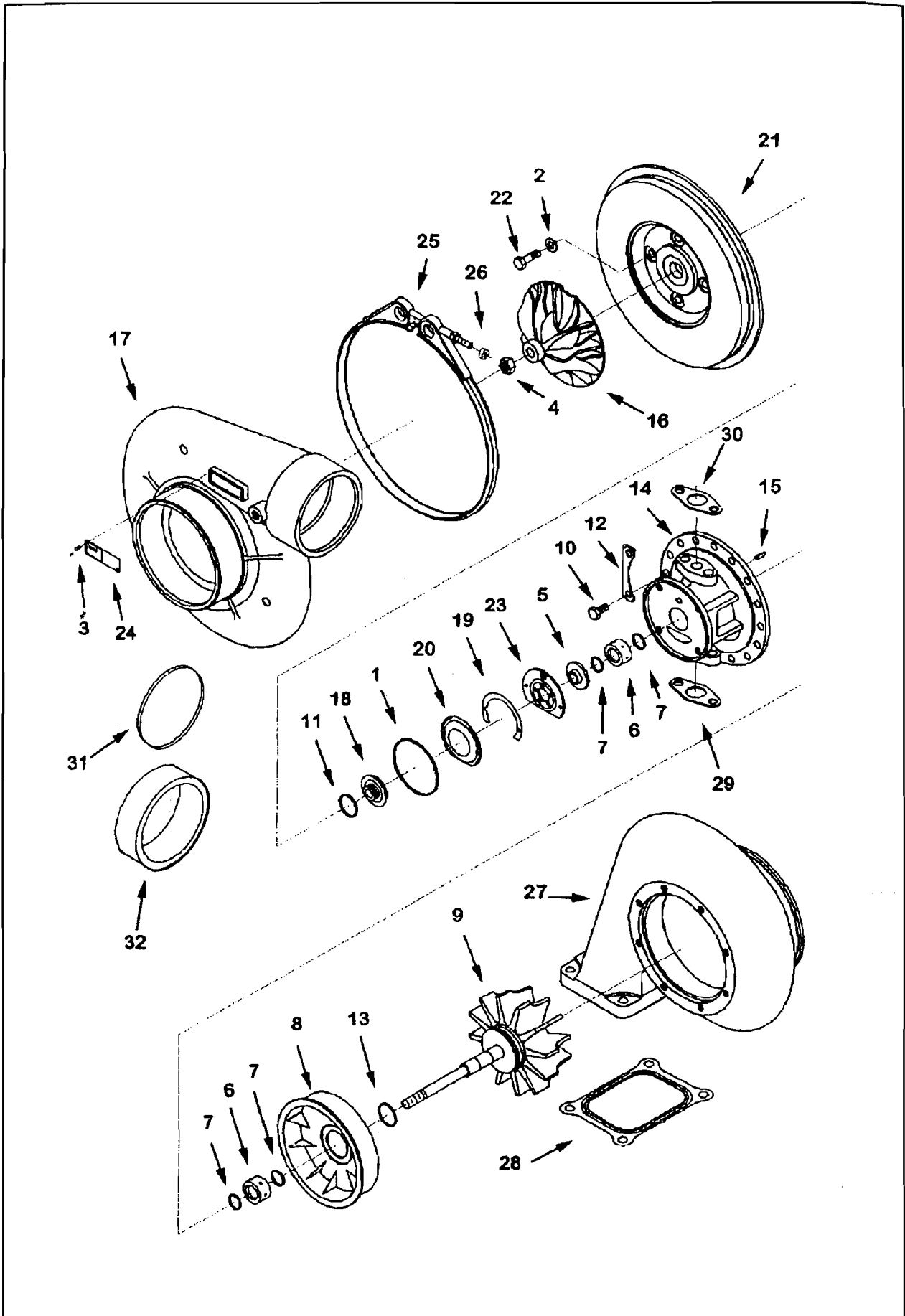

级别 LV	零件号 Part Number	图上标号 Ref No	零件名称 Part Name		数量 Req	备注 Remarks
			中文	英文		
02	3529871		增压器	TURBOCHAGER	1	总成装配
	3502449	1	矩形密封圈	SEAL, RECTANGULAR RING	1	适用于:
	3504967	2	平垫圈	WASHER, PLAIN	4	KTA19-G3(M)
	3519163	3	自攻螺栓	SCREW, DRIVE	2	
	3519535	4	锁紧螺母	NUT, LUCK	1	
	3519623	5	止推环	COLLAR, THRUST	1	
	3519627	6	轴承	BEARING, RURBOCHARGER	2	
	3519641	7	挡圈	RING, RETAINING	4	
	3519783	8	隔热板	SHIELD, TURBOCHARGER	1	
	3521225	9	六角螺栓	SCREW, HEXAGON HEAD CAP	8	
	3521442	10	密封环	SEAL, SPLIT RING	1	
	3522631	11	V型带卡箍	GLAMP, V BAND	1	
	3522904	12	锁片	LOCKPLATE	4	
	3523412	13	密封环	SEAL, SPLIT RING	1	
	3523429	14	轴承壳	HOUSHING, TUR BEARING	1	
	3523980*	15	抛油环	SLINGER, OIL	1	
	3524418	16	调整垫片	SHIM	1	
	3524419	17	挡油板	BAFFLE, HEXAGON HEAD SET	1	
	3525073	18	六角螺栓	SCREW, HEXAGON HEAD SET	4	
	3521033	19	轴和涡轮	SHAFT & WHEEL	1	
	3526985	20	止推轴承	BAEARING, TUR THRUST	1	
	3527348	21	扩压板	DIFFUSER, TURBOCHARGER	1	
	3527369	22	压气机壳	HOUSHING, COMPRESSOR	1	
	3533703	23	叶轮	IMPELLER, TUR COMPRESSOR	1	
	3527619	24	铭牌	DATAPLATE	1	
	3529372	25	六角螺母	NUT, REGULAR HEXAGON	1	
	3524753	26	涡壳	HOUSHING, TURBINE	1	
	201048	28	衬垫	GASKET, INJECTOR	1	
	201049	27	衬垫	GASKET, INJECTOR	1	
	206576	29	增压器衬垫	GASKET, TURBOCHAGER	1	
	3023066	31	O型密封圈	SEAL, O RING	2	
	3023129	30	尘封	SEAL, DUST	1	

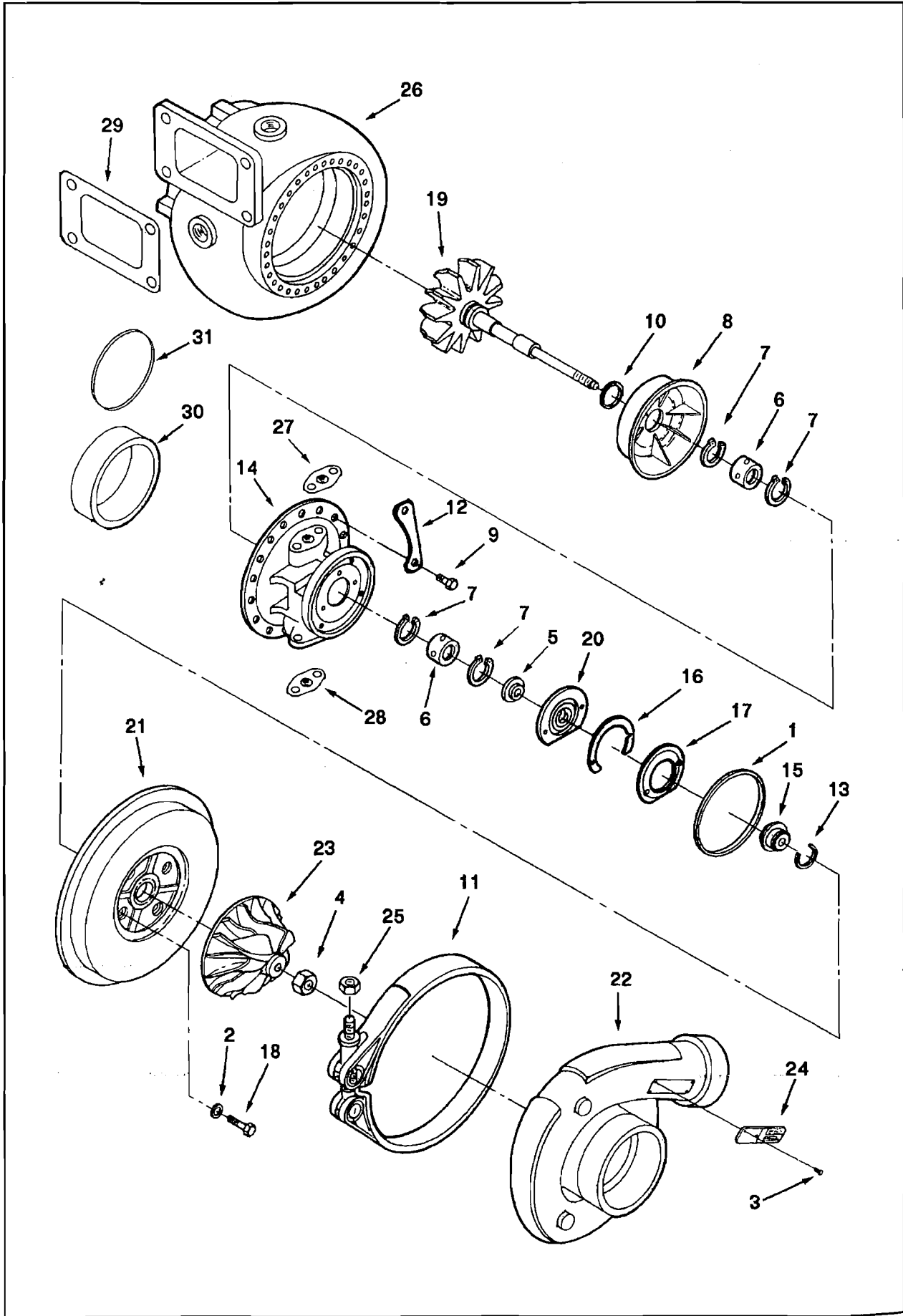

表—61

增压器 Turbocharger

PP 4152

级别 LV	零件号 Part Number	图上标号 Ref No	零件名称 Part Name		数量 Req	备注 Remarks
			中文	英文		
02	3537570		增压器	TURBOCHAGER	1	总成装配
	3502449	1	矩形密封圈	SEAL, RECTANGULAR RING	1	适用于:
	3504967	2	平垫圈	WASHER, PLAIN	4	KTA19-G4(M)
	3519163	3	自攻螺栓	SCREW, DRIVE	2	
	3519535	4	锁紧螺母	NUT, LUCK	1	
	3519623	5	止推环	COLLAR, THRUST	1	
	3519627	6	轴承	BEARING, RURBOCHARGER	2	
	3519641	7	挡圈	RING, RETAINING	4	
	3519783	8	隔热板	SHIELD, TURBOCHARGER	1	
	3521225	9	六角螺栓	SCREW, HEXAGON HEAD CAP	8	
	3521442	10	密封环	SEAL, SPLIT RING	1	
	3522631	11	V型带卡箍	GLAMP, V BAND	1	
	3522904	12	锁片	LOCKPLATE	4	
	3523412	13	密封环	SEAL, SPLIT RING	1	
	3523429	14	轴承壳	HOUSHING, TUR BEARING	1	
	3523980	15	抛油环	SLINGER, OIL	1	
	3524418	16	调整垫片	SHIM	1	
	3524419	17	挡油板	BAFFLE, HEXAGON HEAD SET	1	
	3525073	18	六角螺栓	SCREW, HEXAGON HEAD SET	4	
	3521033	19	轴和涡轮	SHAFT & WHEEL	1	
	3526985	20	止推轴承	BAEARING, TUR THRUST	1	
	3527348	21	扩压板	DIFFUSER, TURBOCHARGER	1	
	3527369	22	压气机壳	HOUSHING, COMPRESSOR	1	
	3533703	23	叶轮	IMPELLER, TUR COMPRESSOR	1	
	3527619	24	铭牌	DATAPLATE	1	
	3529372	25	六角螺母	NUT, REGULAR HEXAGON	1	
	3524753	26	涡壳	HOUSHING, TURBINE	1	
	201048	28	衬垫	GASKET, INJECTOR	1	
	201049	27	衬垫	GASKET, INJECTOR	1	
	206576	29	增压器衬垫	GASKET, TURBOCHAGER	1	
	3023066	31	O型密封圈	SEAL, O RING	2	
	3023129	30	尘封	SEAL, DUST	1	

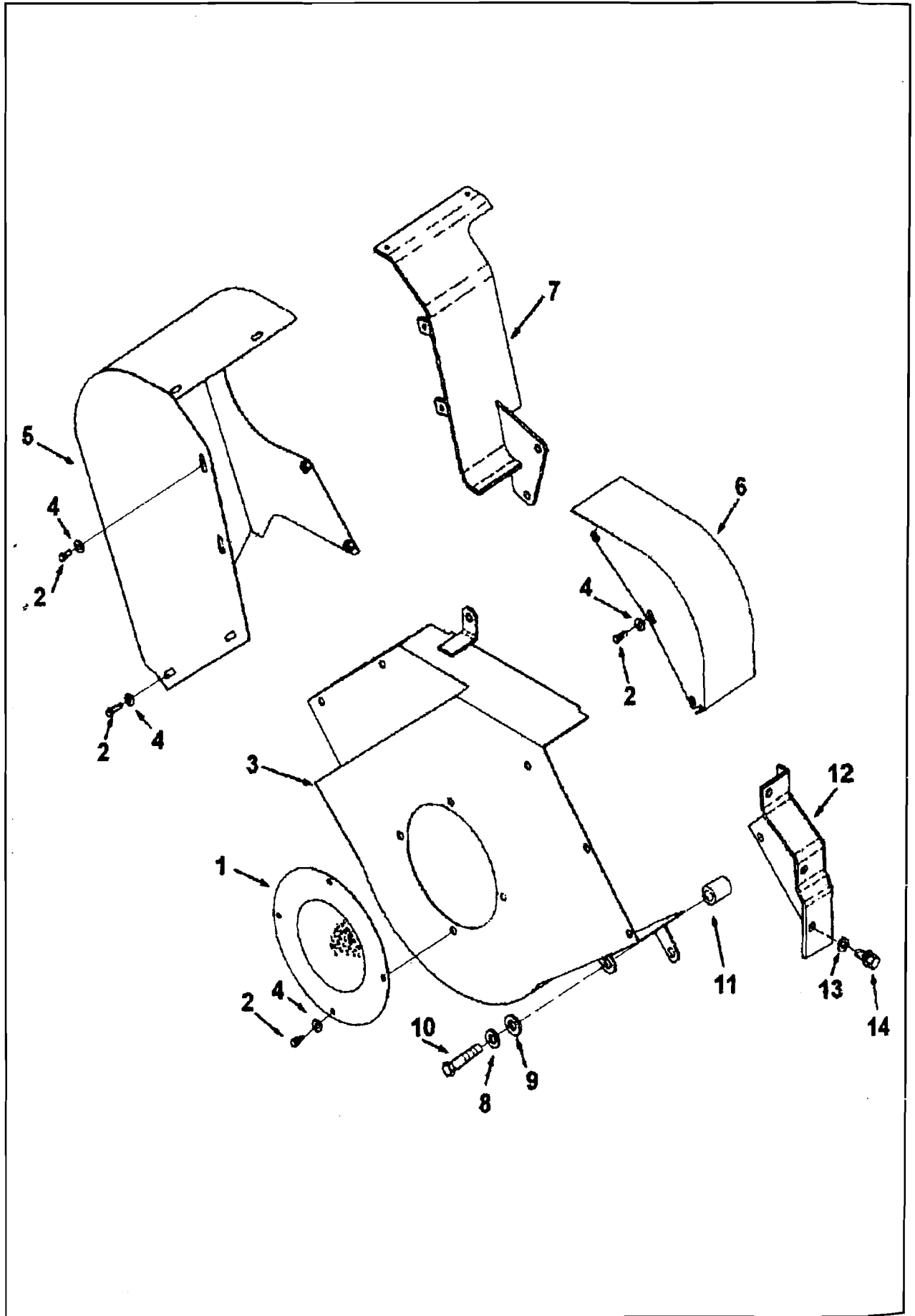

级别 LV	零件号 Part Number	图上标号 Ref No	零件名称 Part Name		数量 Req	备注 Remarks
			中文	英文		
02	3045895		防护罩板	PLANT, DAMPER GUARD	1	
03	3001954	1	减震器防护罩	GUARD, DAMPER	1	
03	3033378	2	带垫螺栓	SCREW, CAPTIVE WASHER CAP	4	
03	S 631	4	平垫圈	WASHER, PLAIN	4	
02	3045896		防护罩	GUARD, PULLEY-L.S.	1	
03	3001924	6	防护罩	GUARD, BELT	1	
03	3033378	2	带垫螺栓	SCREW, CAPTIVE WASHER CAP	4	
03	S 631	4	平垫圈	WASHER, PLAIN	4	
02	3045898		减振器防护罩	GUARD, DAMPER	1	
03	3001926	3	防护罩	GUARD, DAMPER	1	
03	S 125	10	六角螺栓	SCREW, HEXAGON HEAD CAP	2	
03	S 608	9	弹簧垫圈	WASHER, LOCK	2	
03	203310	8	平垫圈	WASHER, PLAIN	2	
03	66945	11	隔套	SPACER, BELT SHIELD	2	
02	3045899		发电机防护罩	GUARD, ALTERNATOR	1	
03	3001903	5	防护罩	GUARD, PROCTIVE	1	
03	3033378	2	带垫螺栓	SCREW, CAPTIVE WASHER CAP	8	
03	S 631	4	平垫圈	WASHER, PLAIN	8	
02	3045900		发电机防护罩支架	BRACKET, ALT. GUARD	1	
03	3001923	7	防护罩支架	BRACKET, PROCTIVE GUARD	1	
02	3045901		发电机防护罩支架	BRACKET, ALT. GUARD	1	
03	3001898	12	支架	BRACKET, BELT GUARD	1	
03	3010595	14	六角螺栓	SCREW, HEXAGON HEAD CAP	1	
03	S 604	13	弹簧垫圈	WASHER, LOCK	1	

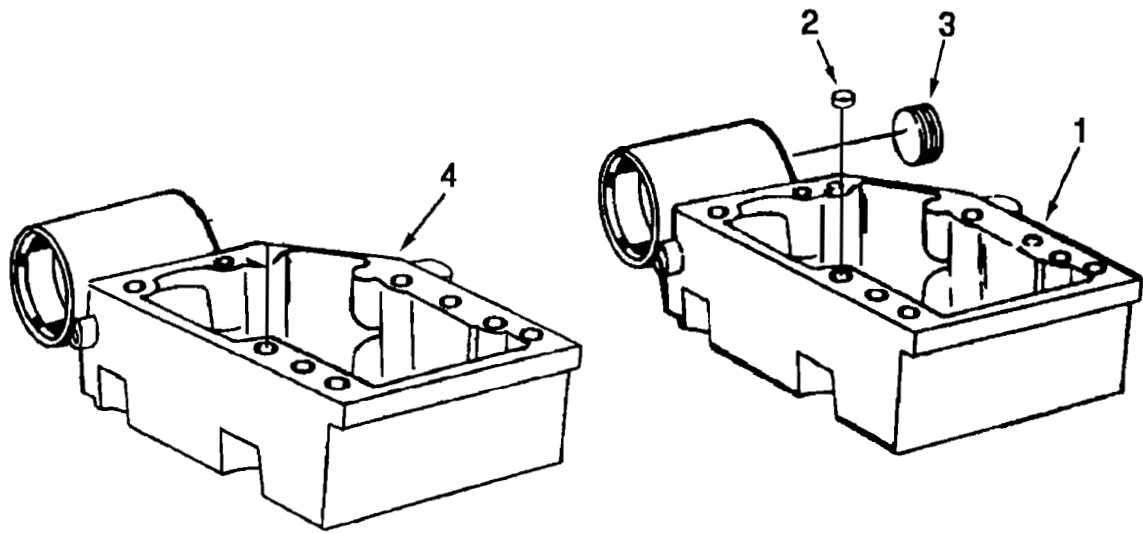

级别 LV	零件号 Part Number	图上标号 Ref No	零件名称 Part Name		数量 Req	备注 Remarks
			中文	英文		
02	3200499		摇臂室	HOUSING, ROCKER	5	适用于: KTA19-G2(M)
03	205129	2	摇臂轴定位环	DOWEL, RING	1	
03	3202193	4	摇臂室	HOUSING, ROCKER LE	1	
02	3200490		摇臂室	HOUSING, ROCKER	1	
03	205129	2	摇臂轴定位环	DOWEL, RING	1	
03	3008469	3	管塞	PLUG, PIPE	1	
03	3202196	1	摇臂室	HOUSING, ROCKER LEVER	1	

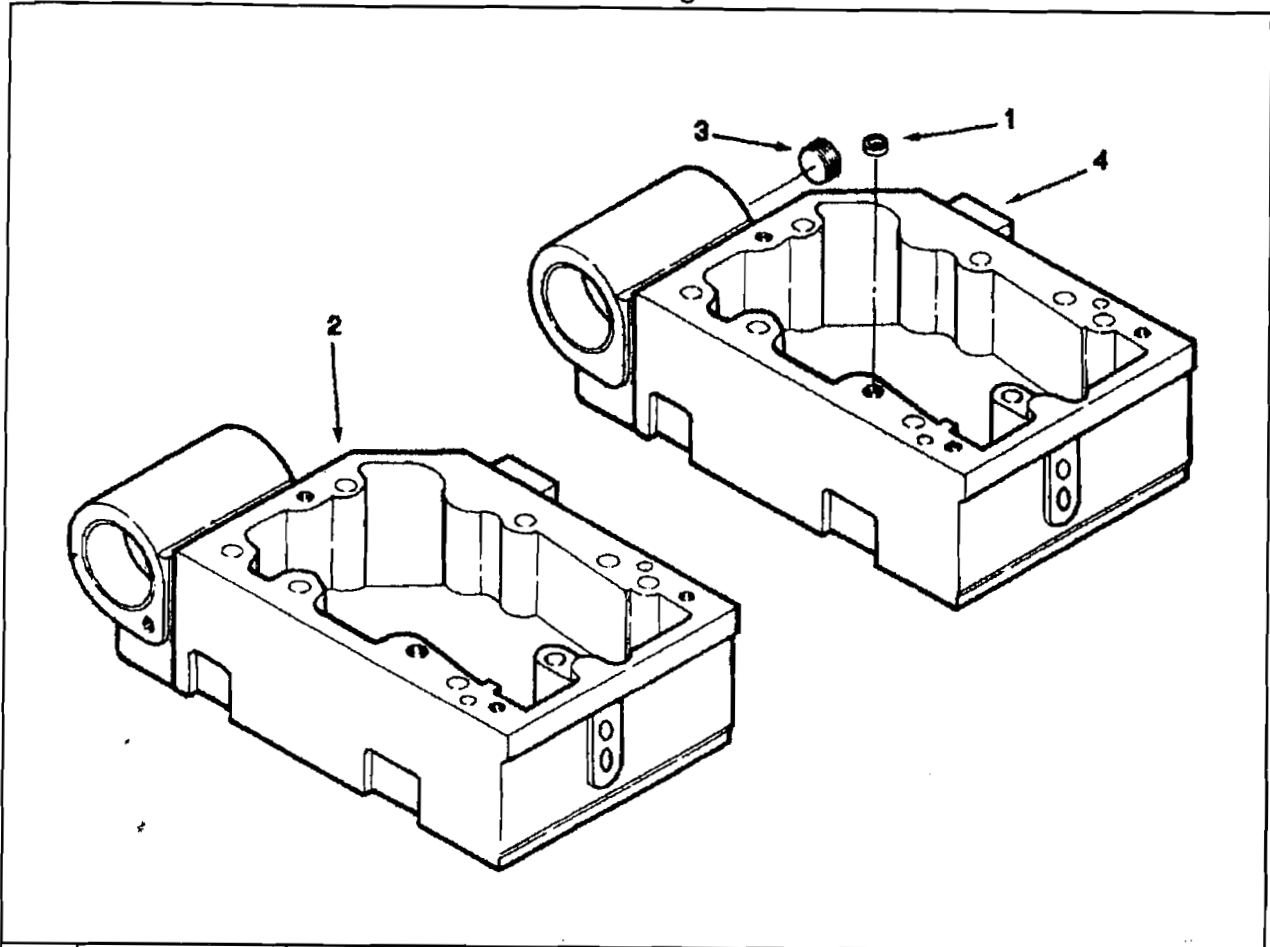

级别 LV	零件号 Part Number	图上标号 Ref No	零件名称 Part Name		数量 Req	备注 Remarks
			中文	英文		
02	3039097		摇臂室	ASSY,ROCKER LEVER HOUSIN	5	适用于:
03	205129	1	摇臂轴定位环	DOWEL, RING	1	KTA19-G3(M)
03	3177713	2	摇臂室	HOUSING,ROCKER LEVER	1	/G4(M)
02	3047708		摇臂室	HOUSING,ROCKER	1	
03	3008469	3	管塞	PLUG,PIPE	1	
03	3039100		摇臂室	ASSY,ROCKER LEVER HOUSIN	1	
04	205129	1	摇臂轴定位环	DOWEL, RING	1	
04	3202198	4	摇臂室	HOUSING,ROCKER LEVER	1	

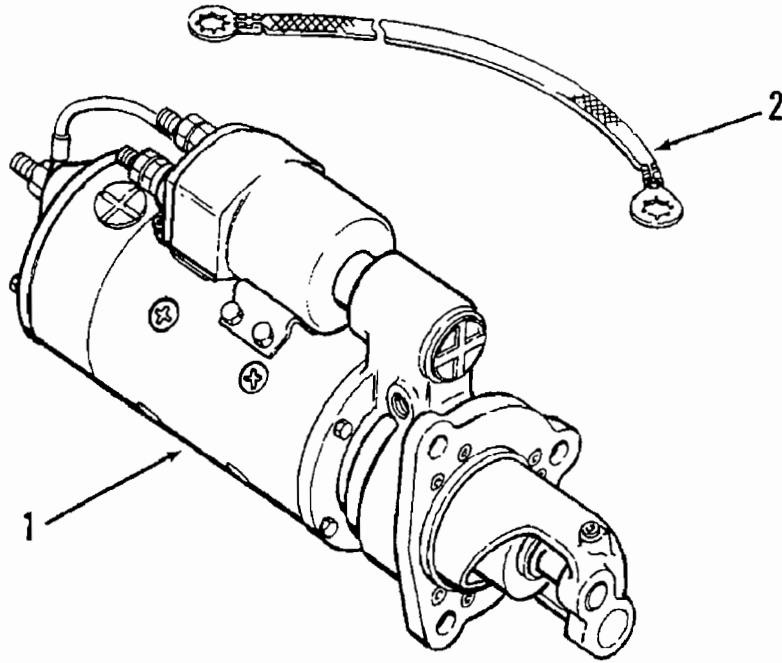

级别 LV	零件号 Part Number	图上标号 Ref No	零件名称 Part Name		数量 Req	备注 Remarks
			中文	英文		
02	3043578		起动马达	MOTOR STARTING	1	
03	3018924	2	接地线	WIRE, GROUND	1	
03	3021038	1	起动马达	MOTOR, STARTNG	1	

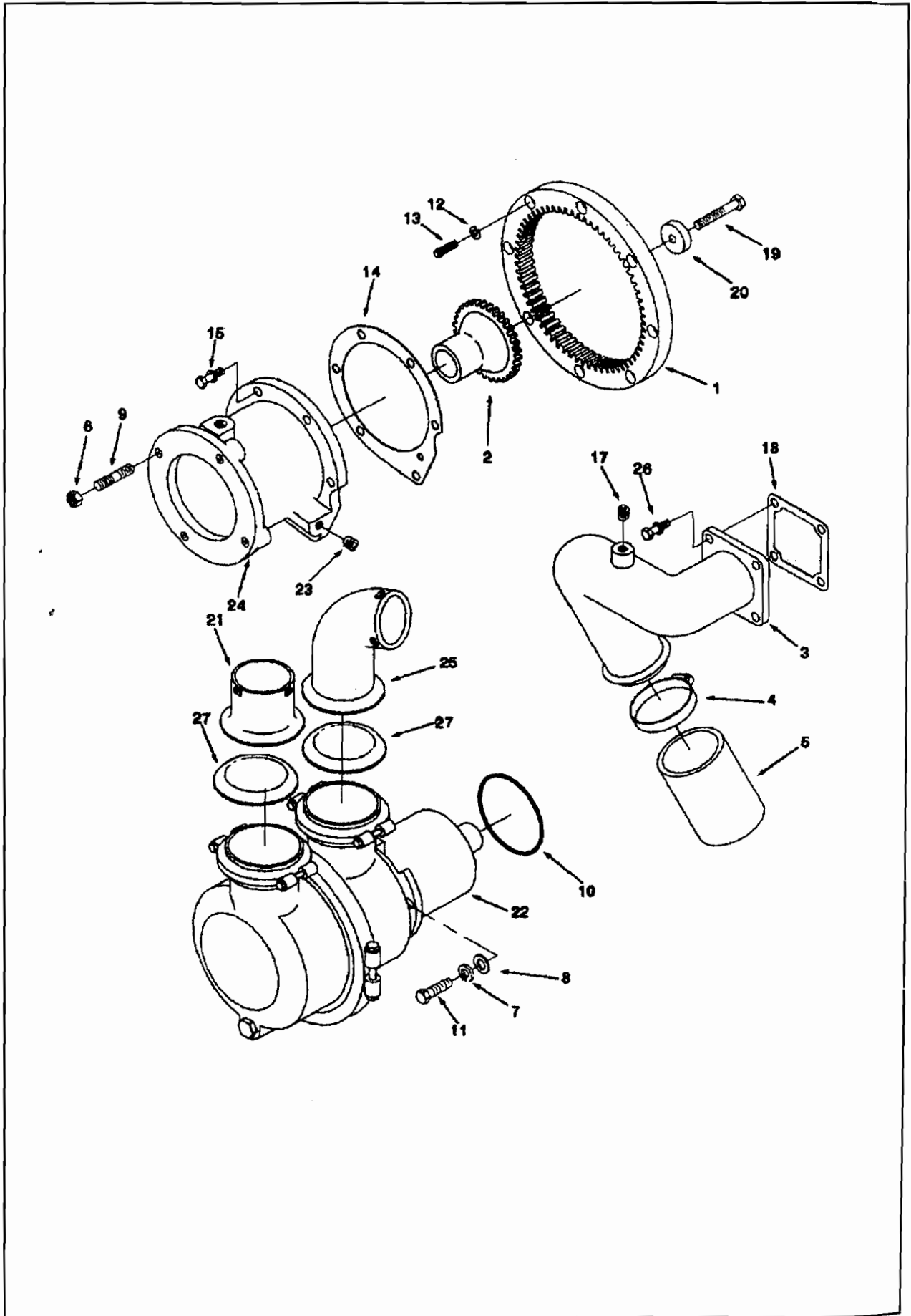

级别 LV	零件号 Part Number	图上标号 Ref No	零件名称 Part Name		数量 Req	备注 Remarks
			中文	英文		
02	3008840	1	海水泵齿圈	GEAR, CAMSHAFT	1	
02	3008874	3	进水接头	CONNECTION, WATER INLET	1	
02	3012090		水管安装	TUBE, MTG WTR	1	
03	43828	F	软管夹箍	CLAMP, HOSE	4	
03	3024128	5	普通软管	HOSE, PLAIN	1	
02	3012097		海水泵齿圈安装	INGGEAR, MTG	1	
03	172512	13	十二角螺栓	SCREW, TWELVE POINT CAP	8	
03	S 605	12	弹簧垫圈	WASHER, LOCK	8	
02	3013432		海水泵支承安装	ADAPTER, MTG	1	
03	3008869	14	海水泵衬垫	GASKET, SEA WATER PUMP	1	
03	3010596	15	带垫圈螺栓	SCREW, CAPTIVE WAS	6	
02	3021730		热交换器管子安装	MTG, HX TUBE	1	
03	3010596	15	带垫圈螺栓	SCREW, CAPTIVE WAS	4	
03	3055769	18	海水泵衬垫	GASKET, SEA WATER PUMP	1	
03	S 602		平垫圈	WASHER, PLAIN	4	
03	S 962	A	管塞	PLUG, PIPE	1	
02	3050954	21	海水泵接头	CONNECTION, SEA	1	
02	3200884	25	海水泵接头	CONNECTION, SEA WATER	1	
02	3655812		海水泵及支承座总成	ASSY, SEA WATER PUMP&SUPP	1	
03	3008841	2	海水泵齿轮	GEAR, SEA WATER PUMP	1	
03	3012096		海水泵安装	PUMP, WTR MTG SEA	1	
04	9740	9	双头螺栓	STUD	1	
04	145592	10	O型密封圈	SEAL, O RING	1	
04	185804	11	六角螺栓	SCREW, HEXAGON HEAD CAP	3	
04	S 231	6	螺母	NUT, REGULAR HWXAGON	1	
04	S 610	7	弹簧垫圈	WASHER, LOCK	4	
04	S 622	8	平垫圈	WASHER, PLAIN	4	
03	3025084		海水泵驱动齿轮安装	PUMP, DRIVE GEAR MTG	1	
04	177020	19	六角螺栓	SCREW, HEXAGON HEAD CAP	1	
04	3010708	20	平垫圈	WASHER, PLAIN	1	
03	3074540	22	海水泵	PUMP, SEA WATER	1	
03	3074614		海水泵支承座	ADAPTER, RAW WATER PUMP	1	
04	3008466	23	管塞	PLUG, PIPE	2	
04	3034483	24	海水泵支承	SUPPORT, SEA WATER PUMP	1	

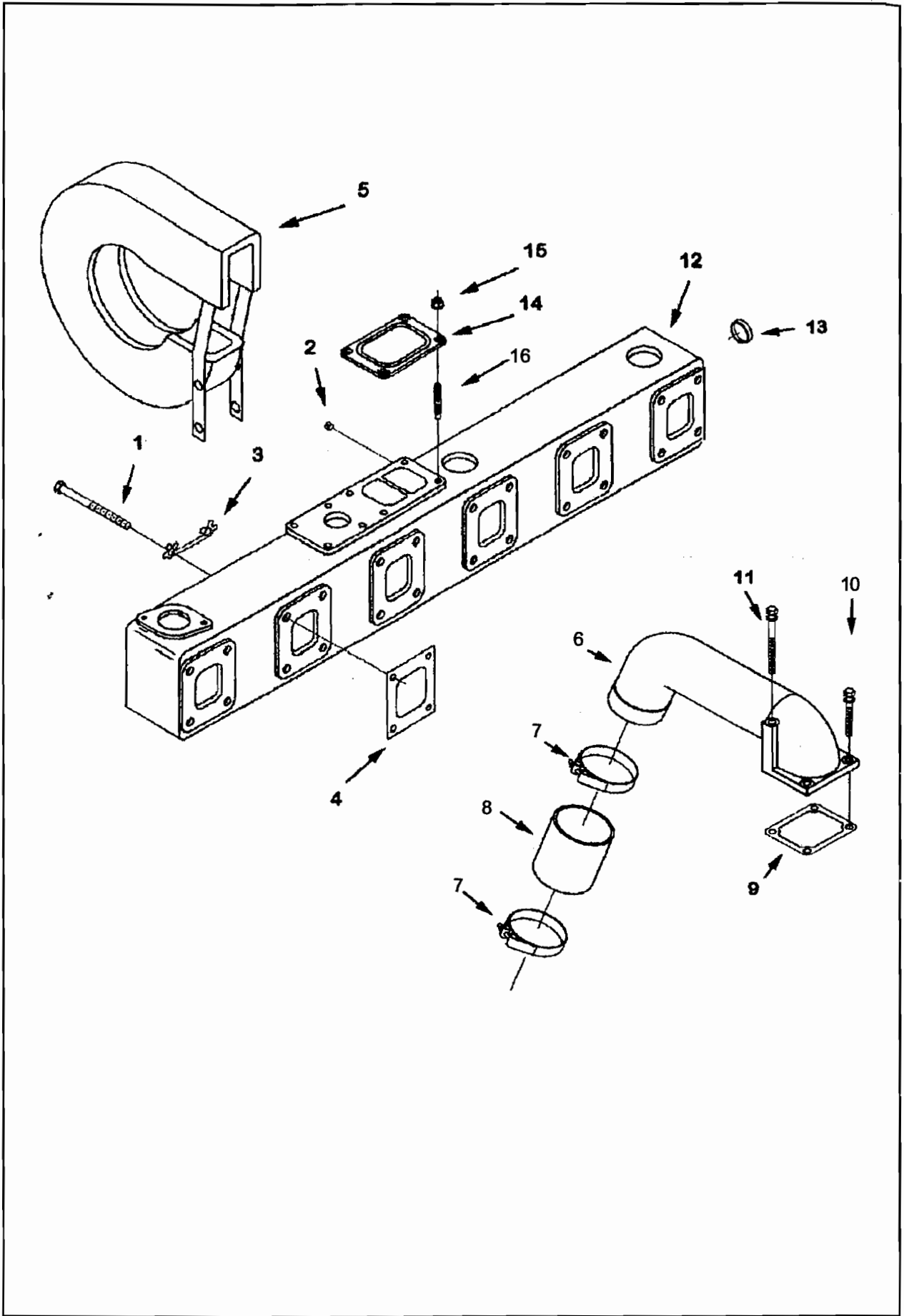

级别 LV	零件号 Part Number		图上标号 Ref No	零件名称 Part Name		数量 Req	备注 Remarks
				中文	英文		
02	3003697		5	增压器隔热罩	BLANKET, TURBOCHARGER HEA	1	适用于: KTA19-G2(M)
02	3016139		6	空气跨越联接管	CONNECTION, AIR CROSSOVER	1	
02	3035952			空气跨越管安装	MTG, AIR CROSSOVER	1	
03	S 602			平垫圈	WASHER, PLAIN	4	
03	140315		7	T型螺栓夹箍	CLAMP, T BOLT	2	
03	3012472		10	带垫螺栓	SCREW, CAPTIVE WASHER CAP	2	
03	3016142		8	普通软管	HOSE, PLAIN	1	
03	3032161		9	接头衬垫	GASKET, CONN	1	
03	S 106	C	11	六角螺栓	SCREW, HEXAGON HEAD	2	
03	S 604			弹簧垫圈	WASHER, LOCK	2	
02	3655046		12	湿式排气管	MANIFOLD EXHAUST, WET	1	
02	MP45146			排气管安装	EXH MFD	1	
03	3001405		3	锁紧片	LOCKPLATE	12	
03	3043097		4	衬垫	GASKET, EXHAUST MANIFOLD	6	
03	S 164	B	1	六角螺栓	SCREW, HEXAGON HEAD CAP	24	
03	S 910	B	2	管塞	PLUG, PIPE	2	

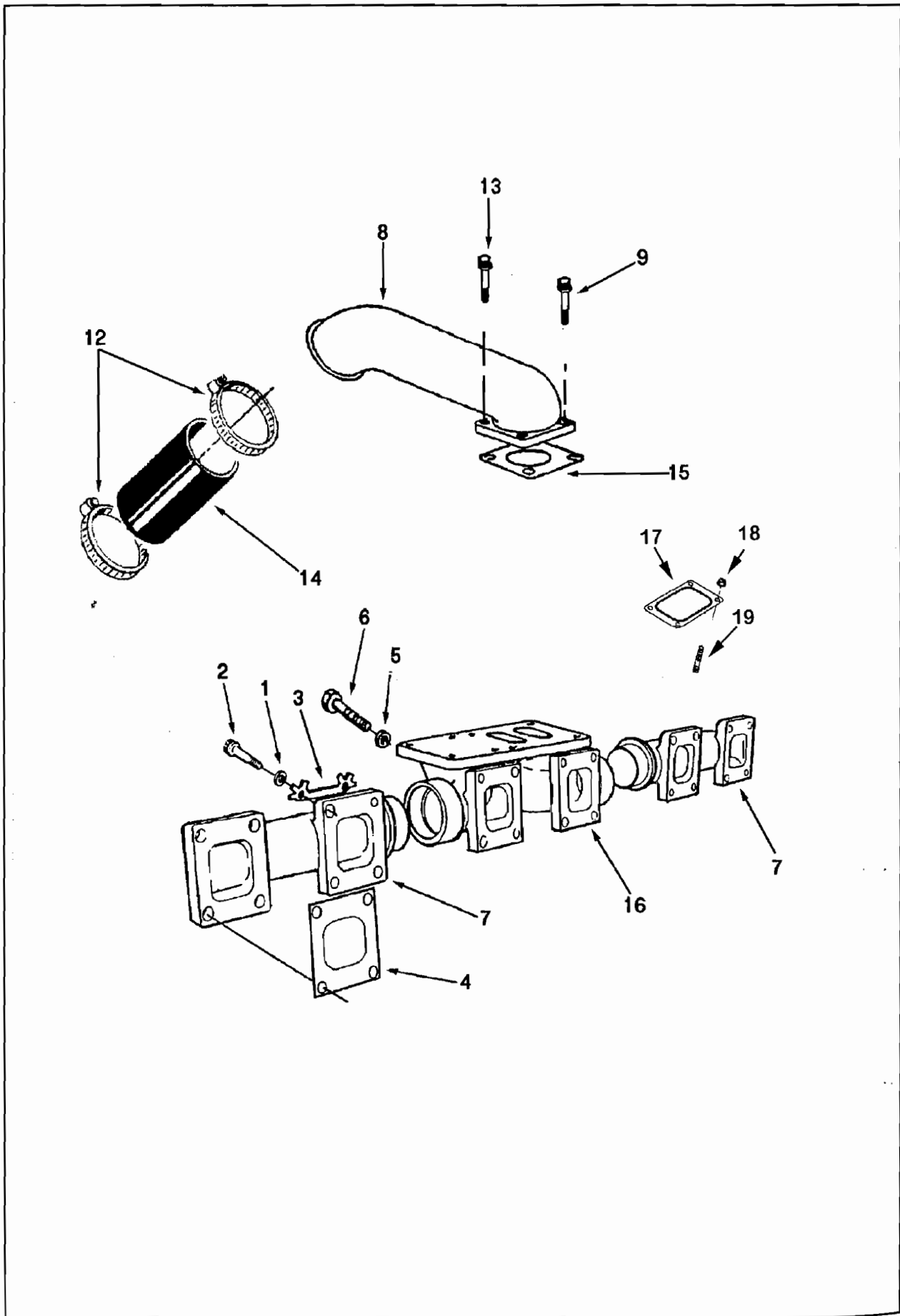

级别 LV	零件号 Part Number	图上标号 Ref No	零件名称 Part Name		数量 Req	备注 Remarks
			中文	英文		
02	3037824	7	排气歧管	MANIFOLD, EXHAUST	2	适用于: KTA19-G3(M)
02	3166256		排气歧管	MANIFLOD, EXHAUST	1	/G4(M)
03	3042353	19	双头螺栓	STUD	4	
03	3080980	16	排气歧管	MANIFLOD, EXHAUST	1	
02	3088319		排气歧管安装	MANIFOLD, EXHAUST	2	
03	3043097	4	衬垫	GASKET, EXHAUST MANIFOLD	2	
03	3046283	2	六角螺栓	SCREW, HEXAGON HEAD	8	
03	3046286	1	隔套	SPACER, MOUNTING	8	
03	3088317	3	锁紧片	LOCKPLATE	4	
02	3088318		排气歧管安装	MANIFOLD, EXHAUST	1	
03	3035310	5	平垫圈	WASHER, PLAIN	4	
03	3043097	4	衬垫	GASKET, EXHAUST MANIFOLD	2	
03	3046283	2	六角螺栓	SCREW, HEXAGON HEAD	4	
03	3046286	1	平垫圈	SPACER, MOUNTING	4	
03	3066497	6	六角螺栓	SCREW, HEX FAANGE HEAD CA	4	
03	3088317	3	锁紧片	LOCKPLATE	4	
02	3096217		增压器安装	TURBO MOUNTING	1	
03	206576	17	增压器衬垫	GASKET, TURBOCHAGER	1	
03	219138	18	六角螺母	NUT, REGULAR HEXAGON	4	
02	3016139	8	空气跨越联接管	CONNECTION, AIR CROSSOVER	1	
02	3035952		空气跨越管安装	MTG, AIR CROSSOVER	1	
03	127362		平垫圈	WASHER, PLAIN	4	
03	140315	12	T型螺栓夹箍	CLAMP, T BOLT	2	
03	3016142	14	普通软管	HOSE, PLAIN	1	
03	3032161	15	接头衬垫	GASKET, CONN	1	
03	3035624	13	带垫螺栓	SCREW, CAPTIVE WASHER CAP	2	
03	S 106 C	9	六角螺栓	SCREW, HEXAGON HEAD	2	
03	S 604		弹簧垫圈	WASHER, LOCK	2	

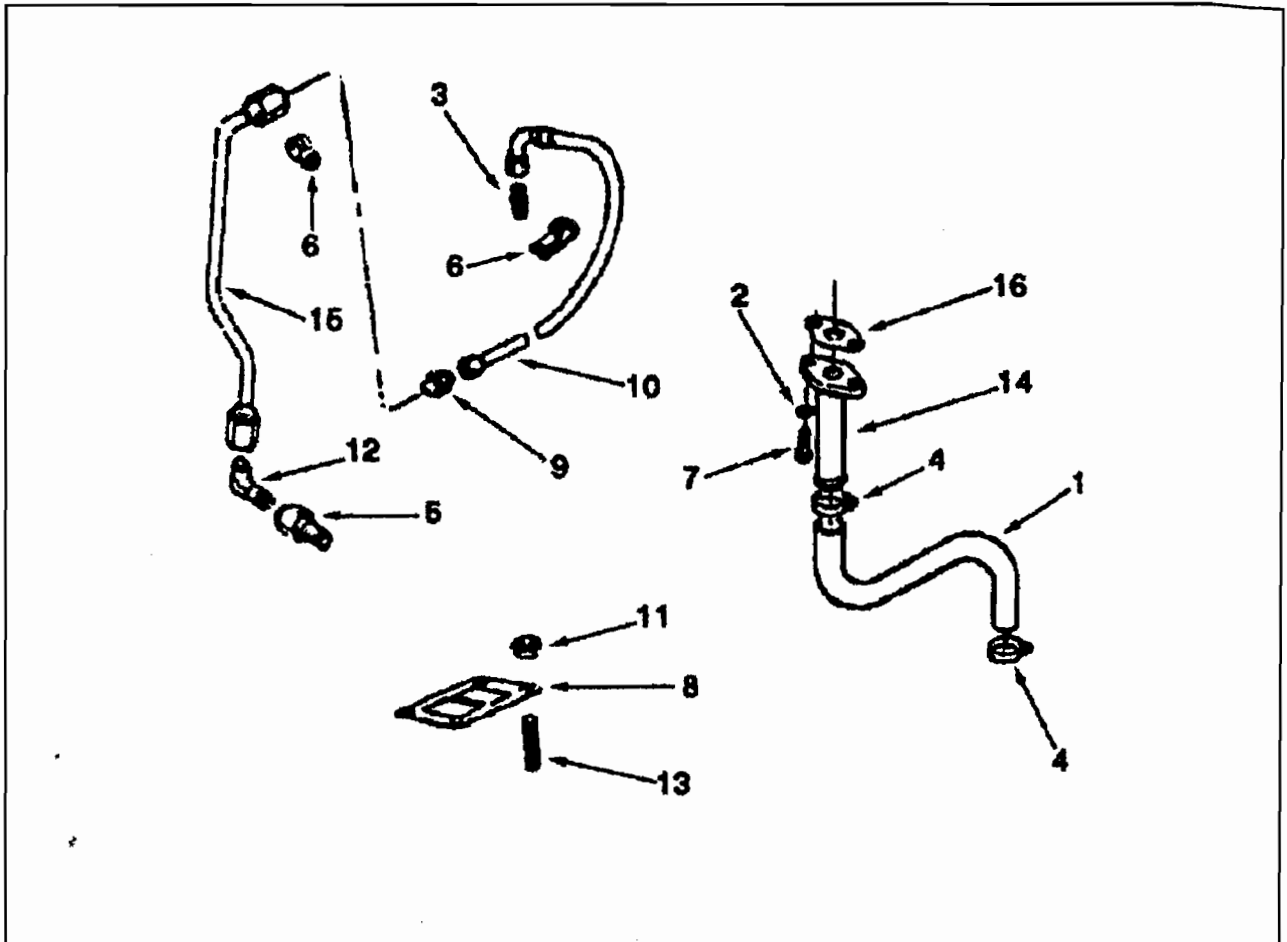

级别 LV	零件号 Part Number	图上标号 Ref No	零件名称 Part Name		数量 Req	备注 Remarks
			中文	英文		
02	3024150		增压器安装	TURBOCHAGER	1	适用于： KTA19-G2 (M)
03	68425	6	夹子	CLIP	2	
03	118346	5	接头	UNION, MALE	1	
03	191772	7	十二角螺栓	SCREW, TWELVE POINT CAP	2	
03	206576	8	增压器衬垫	GASKET, TURBOCHARGER	1	
03	206943	9	管接头	UNION, ADAPTER	1	
03	215195	10	柔性软管	HOSE FLEXIBLE	1	
03	219138	11	六角螺母	NUT, REGULAR HEXAGON	4	
03	3003536	12	增压器回油弯管	COUPLING, ELBOW HOSE	1	
03	3026806	4	抱箍	CLAMP, HOSE	2	
03	3042353	13	双头螺栓	STUD	4	
03	3200178	14	增压器回油管	TUBE, TUR OIL DRAIN	1	
03	3200273	15	增压器供油管	TUBE, TURBO OIL SUPPLY	1	
03	3202117	16	衬垫	GASKET, CONNECTION	1	
03	AS16025	NF	软管	HOSE	1	
03	S 604		弹簧垫圈	WASHER, LOCK	2	
03	S 1039	A	阳性管接头	CONNECTOR, MALE	1	

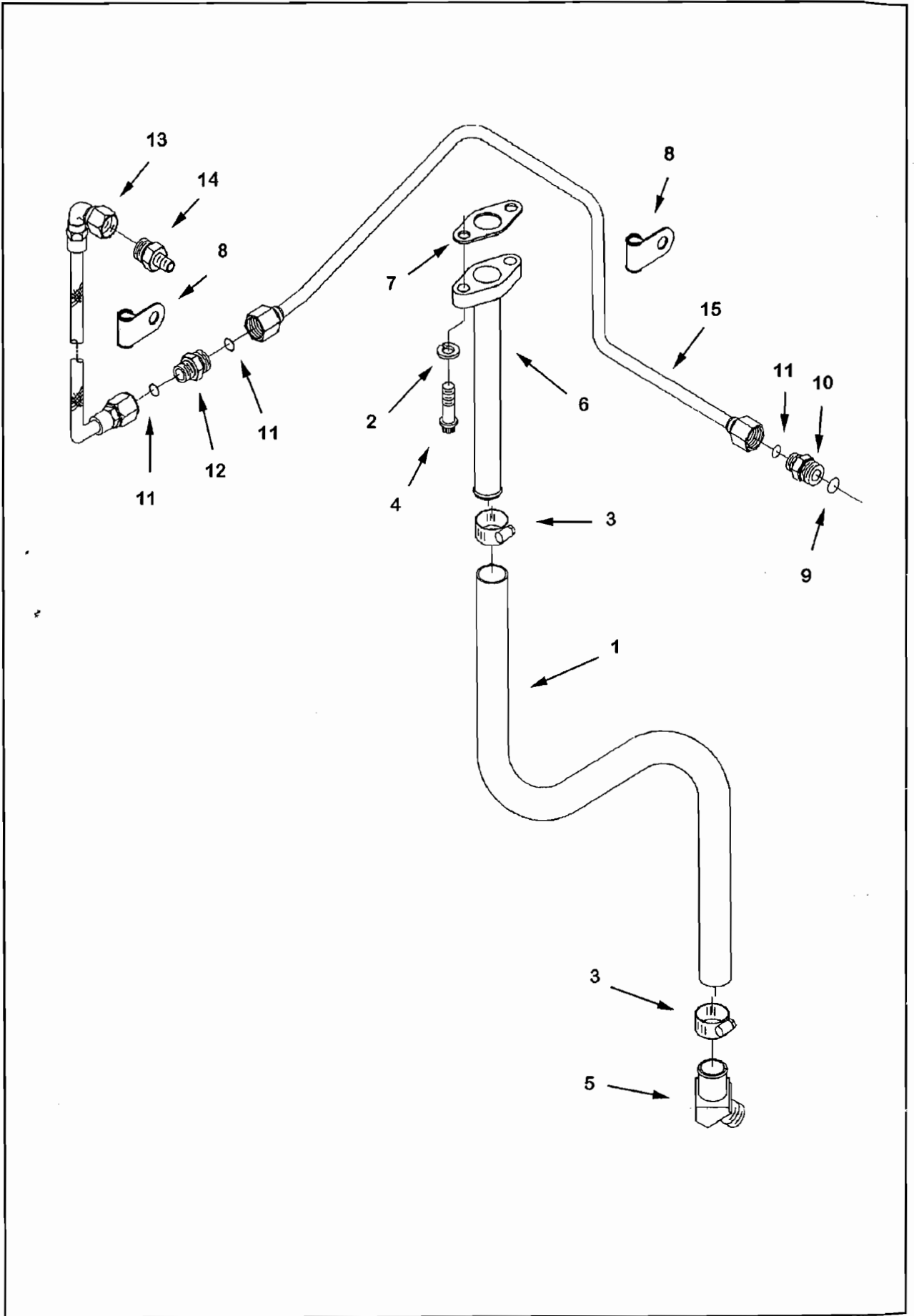

级别 LV	零件号		图上标号 Ref No	零件名称 Part Name		数量 Req	备注 Remarks
	Part Number			中文	英文		
02	3003536		5	增压器回油管	ELBOW, TURBO OIL RETURN	1	总成装配
02	3096213			增压器回油管及安装	TURBO OIL DRAIN	1	适用于:
03	43828	A	3	软管卡箍	CLAMP, HOSE	2	KTA19-G3(M)
03	191772		4	十二角螺栓	SCREW, TWELVE POINT	2	/G4(M)
03	3200178		6	增压器回油管	ASSY, TURBO DRAIN	1	
03	3202117		7	衬垫	GASKET, CONNECTION	1	
03	AS16025	NF	1	软管	HOSE, FLEXIBLE	1	
03	S 604		2	弹簧垫圈	WASHER, LOCK	2	
02	3096220			增压器供油管及安装	TURBO OIL SUPPLY	1	
03	3026793		8	夹子	CLIP	2	
03	3081950			阳性弯接头	UNION, MALE	1	
04	3037537		9	O型密封圈	SEAL, O RING	1	
04	3085824		10	阳性接头	UNION, MALE	1	
04	3922794		11	O型圈	SEAL, O RING	1	
03	3086016			阳性接头	UNION, MALE	1	
04	3086040		12	阳形接头	UNION, MALE	1	
04	3922794		11	O型圈	SEAL, O RING	2	
03	3086055		13	柔性软管	HOSE, FLEXIBLE	1	
03	3627697		14	阳性管接头	UNION, MALE	1	
03	3811992		15	增压器供油管	TUBE LUB OIL SUPPLY	1	

级别 LV	零件号 Part Number	图上标号 Ref No	零件名称 Part Name		数量 Req	备注 Remarks
			中文	英文		
02	3011224	1	旁通水管	TUBE, WATER BYPASS	1	总成装配
02	3011763		旁通水管安装	TUBE, WATER BYPASS MTG	1	
03	43828 D	7	管夹	CLAMP, HOSE	2	
03	70624	2	O型密封圈	SEAL, O RING	1	
03	3010299	3	旁通水管接头	CONNECTION, WATER BYPASS	1	
03	3010596	4	带垫圈螺栓	SCREW, CAPTIVE WAS	2	
03	3015283	5	带垫螺栓	SCREW, CAPTIVE WAS	1	
03	3165360	8	旁通水管接头衬垫	GASKET, CONNECTI	1	
03	3063240	6	软管	HOSE, PLAIN	1	
03	3201287	9	夹子	CLIP	1	
02	3201155		机油冷却器总成	COOLER, ENGINE CAST	1	
03	127362	13	平垫圈	WASHER, PLAIN	10	
03	206973	14	冷却器芯衬垫	GASKET, COOLER ELEMENT	4	
03	3012478	15	带垫螺栓	SCREW, CAPTIVE WASHER	2	
03	3037536		螺塞	PLUG, THREADED	3	
04	3037537		O型密封圈	SEAL, O RING	1	
04	3040813	22	螺塞	PLUG, THREADED	1	
03	3042889	16	螺栓	SCREW, CAPTIVE W	7	
03	3065791	17	变扭器冷却器衬垫	GASKET, TOR CNV OIL COOLE	1	
03	3078053	10	带垫螺栓	SCREW, CAPTIVE WASHER	8	
03	3085955	23	机油冷却器壳	HOUSING, OIL COOLER	1	
03	3090241	20	机油冷却器盖	COVER, LUB OIL COOLER	1	
03	3165999	12	放水开关	DRAIN, COCK	1	
03	3200781		放水塞	PLUG, HEATER HOLE	1	
04	145540	18	O型密封圈	SEAL, O RING	1	
04	206256	19	放水塞	PLUG, DRAIN	1	
03	3202101	22	螺塞	PLUG, THREADED	2	
04	3046943		O型密封圈	SEAL, O RING	1	
04	3050897		螺塞	PLUG, THREADED	1	
03	3331668	21	冷却器芯	CORE, COOLER	2	
02	3201192		机油冷却器安装	COOLER, MTG	1	
03	S 602	25	平垫圈	WASHER, PLAIN	4	
03	205275	26	十二角螺栓	SCREW, TWELVE POINT CAP	4	
03	3033038	27	带垫螺栓	SCREW, CAPTIVE WASHER	2	
03	3040838	28	带垫螺栓	SCREW, CAPTIVE WAS	10	
03	3042890	30	螺栓	SCREW, CAPTIVE W	14	
03	3065790	31	机油冷却器壳衬垫	GASKET, LUB OIL CLR HSG	1	
03	S 604	24	弹簧垫圈	WASHER, LOCK	4	

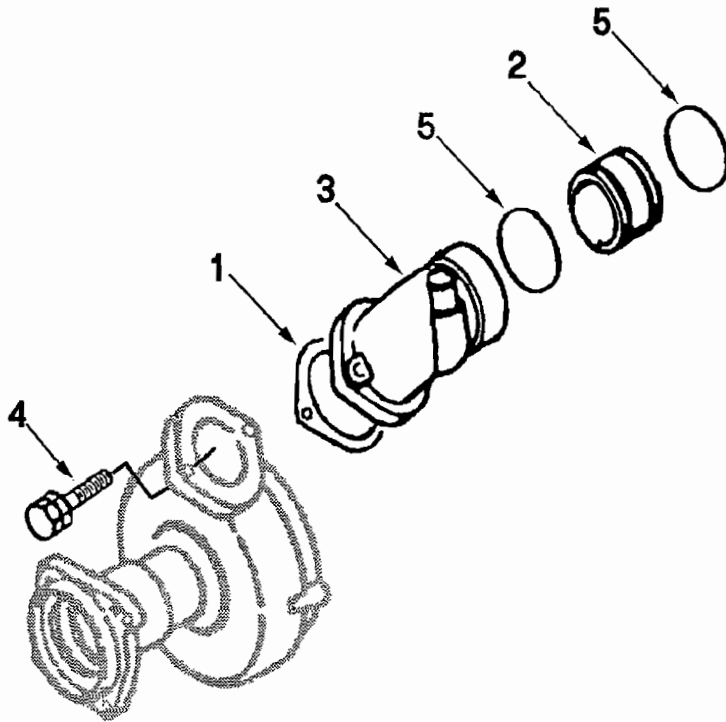

级别 LV	零件号 Part Number	图上标号 Ref No	零件名称 Part Name		数量 Req	备注 Remarks
			中文	英文		
02	AR45710		出水管接头	CONNECTION, WTR OUTLET	1	
03	205289	1	出水接头衬垫	GASKET, WTR OUTLET CONN	1	
03	206998	2	输水管	TUBE, WATER TRANSFER	1	
03	3002192	3	出水管接头	CONNECTION, WATER OUTLET	1	
03	3010596	4	带垫圈螺栓	SCREW, CAPTIVE WAS	2	
03	3028291	5	O型密封圈	SEAL, O RING	2	

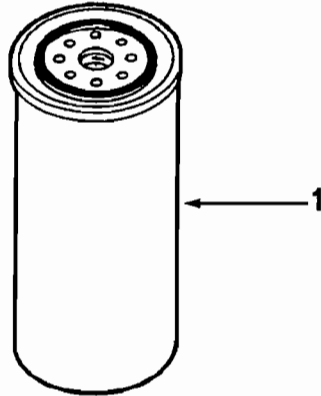

级别 LV	零件号 Part Number	图上标号 Ref No	零件名称 Part Name		数量 Req	备注 Remarks
			中文	英文		
02	4058965	1	水滤器	ELEMENT, CRN RESISTOR	1	适用于:
02	3888312		水滤器防腐剂	INHIBTOR, CORROSION	1	KTA19-G2(M)
02	4058965	1	水滤器	ELEMENT, CRN RESISTOR	1	适用于: KTA19-G3(M)

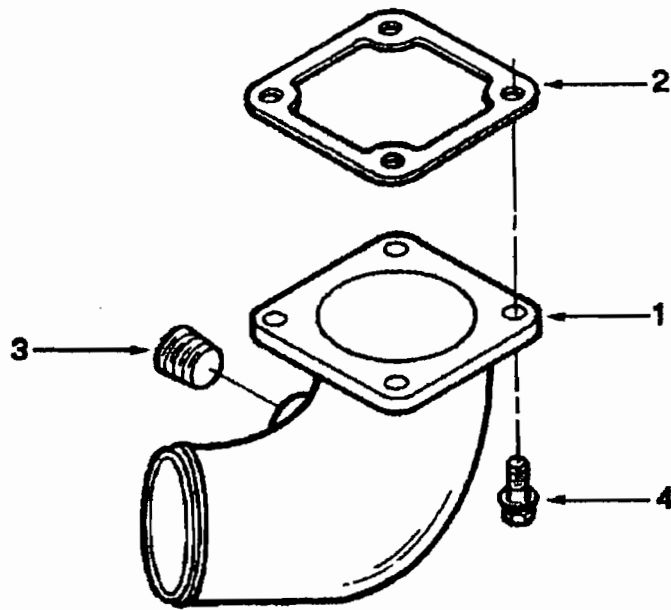

级别 LV	零件号 Part Number	图上标号 Ref No	零件名称 Part Name		数量 Req	备注 Remarks
			中文	英文		
02	3014212	1	进水管接头	CONN, WATER INLET	1	
02	3202339		进水管安装	MTG, WATER INLET	1	
03	205288	2	进水管衬垫	GASKET, WTR INLET	1	
03	3008470	3	管塞	PLUG, PIPE	1	
03	3010595	4	六角螺栓	SCREW, CAPTIVE WAS	4	

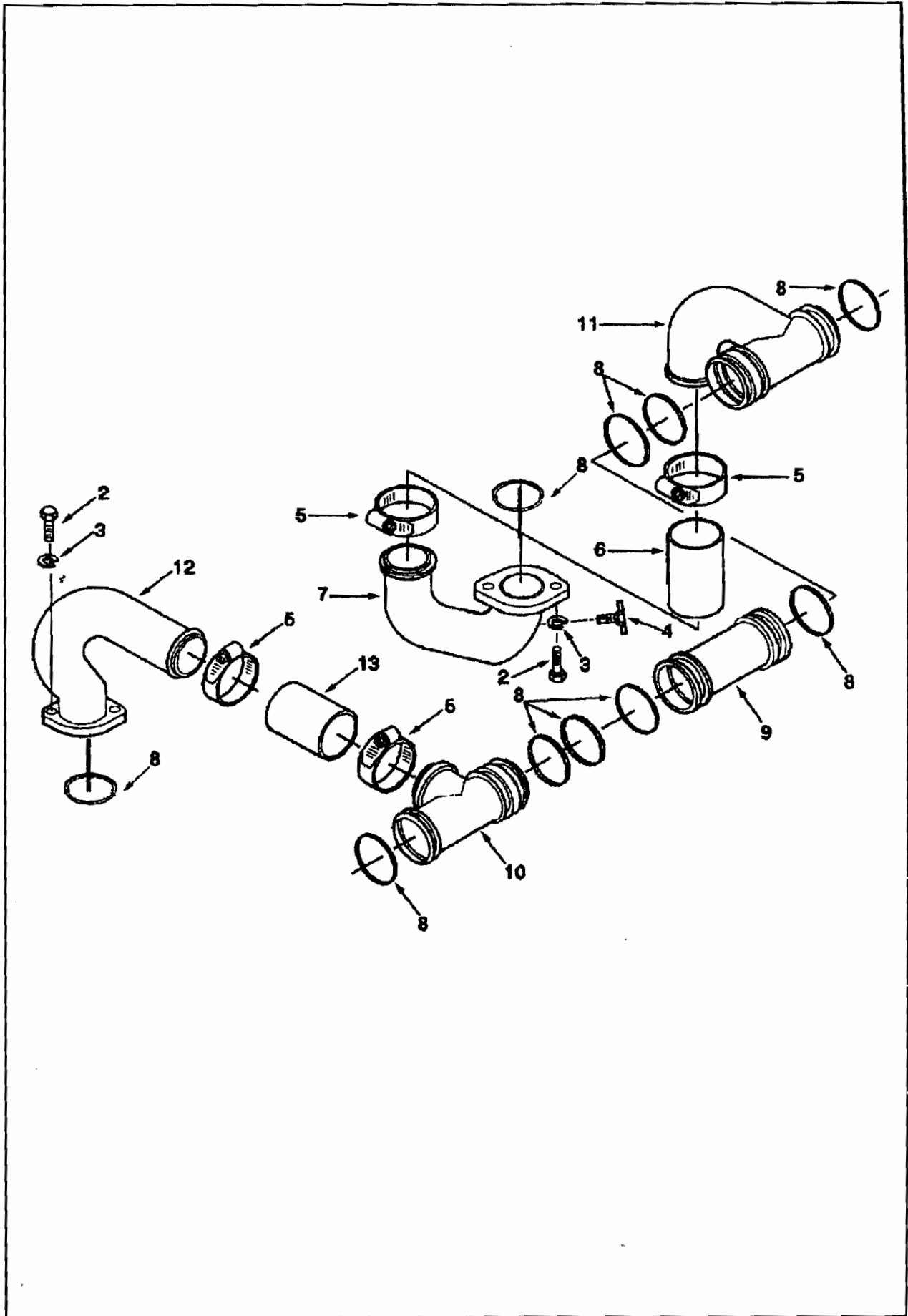

级别 LV	零件号 Part Number		图上标号 Ref No	零件名称 Part Name		数量 Req	备注 Remarks
				中文	英文		
O2	3009063			後水管及安装	CONNECTION, REAR WTR CRO	1	适用于: KTA19-G2(M)
O3	43828	C	5	软管卡箍	CLAMP, HOSE	2	
O3	69793		2	带垫螺栓	SCREW, CAPTIVE WASHER CAP	2	
O3	3004718		7	旁通水管接头	CONNECTION, WTR MFD	1	
O3	3028291		8	O型密封圈	SEAL, O RING	1	
O3	3064697		13	软管	HOSE, PLAIN	1	
O3	3165998		4	放水开关	DRAINCOCK	1	
O3	S 606	A	3	弹簧垫圈	WASHER, LOCK	2	
O2	3009064			水管总成	MANIFOLD, WATER	1	
O3	207233		9	输水管	TUBE, WATER TRANSFER	3	
O3	3003662		10	输水管	TUBE, WATER TRANSFER	1	
O3	3004716		11	输水管	TUBE, WATER TRANSFER	1	
O3	3028291		8	O型密封圈	SEAL, O RING	10	
O2	3009065			前水管及安装	CONNECTION, FRT WTR CROS	1	
O3	43828	C	5	软管卡箍	CLAMP, HOSE	2	
O3	3003657		12	旁通水管接头	CONNECTION, WATER TRANSFE	1	
O3	3028291		8	O型密封圈	SEAL, O RING	1	
O3	3063240		13	软管	HOSE, PLAIN	1	
O3	3200281		6	平垫圈	WASHER, PLAIN	2	
O3	S 112		2	螺栓	SCREW, HEXAGON HEAD CAP	2	
O3	S 604			弹簧垫圈	WASHER, LOCK	2	

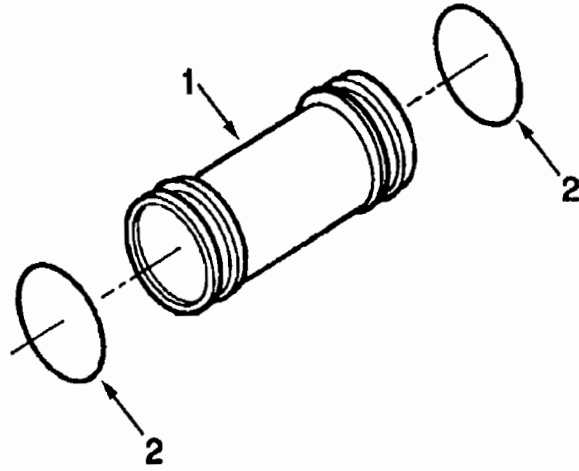

级别 LV	零件号 Part Number	图上标号 Ref No	零件名称 Part Name		数量 Req	备注 Remarks
			中文	英文		
02	AR12333		输水管	TUBE, WATER TRANS	5	适用于:
03	207233	1	输水管	TUBE, WATER TRANSF	1	KTA19-G3(M)
03	3028291	2	O型密封圈	SEAL, O RING	2	/G4(M)

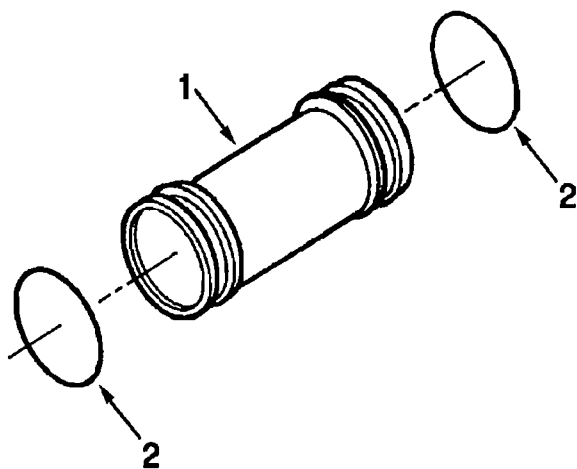

级别 LV	零件号 Part Number	图上标号 Ref No	零件名称 Part Name		数量 Req	备注 Remarks
			中文	英文		
02	AR12333		输水管	TUBE, WATER TRANS	5	适用于:
03	207233	1	输水管	TUBE, WATER TRANSF	1	KTA19-G3(M)
03	3028291	2	O型密封圈	SEAL, O RING	2	/G4(M)

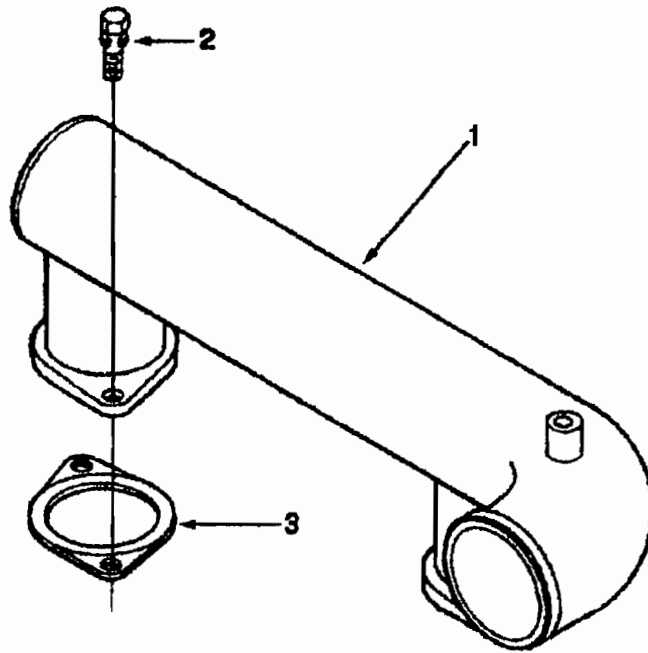

级别 LV	零件号 Part Number	图上标号 Ref No	零件名称 Part Name		数量 Req	备注 Remarks
			中文	英文		
02	3008862	1	出水管接头	CONNECTION, WATER	1	
02	3013434		出水管接头安装	CONNECTION, WATER	1	
03	3010596	2	带垫圈螺栓	SCREW, CAPTIVE WAS	4	
03	3165360	3	出水管接头衬垫	GASKET, CONNECTI	2	

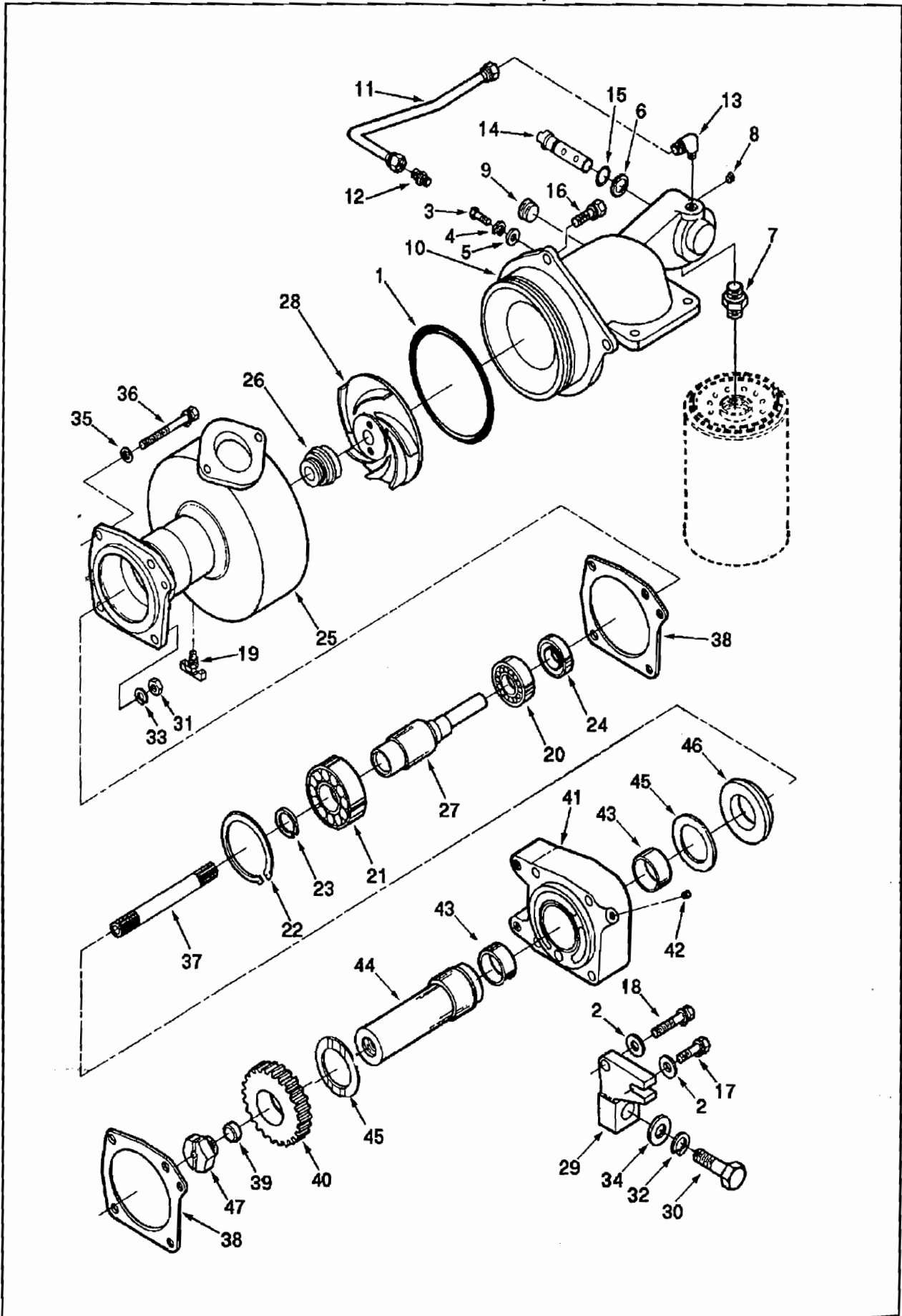

级别 LV	零件号 Part Number	图上标号 Ref No	零件名称 Part Name		数量 Req	备注 Remarks
			中文	英文		
02	3098960		水泵	PUMP, WATER	1	
03	146523	1	O型密封圈	SEAL, O RING	1	
03	3005594	2	平垫圈	WASHER, PLAIN	2	
03	3010529		进水接头	CONNECTION, WATER INLET	1	
04	S 114	3	六角螺栓	SCREW, CAPTIVE WAS	1	
04	S 600	4	弹簧垫圈	WASHER, LOCK	1	
04	S 631	5	平垫圈	WASHER, PLAIN	1	
04	205363	6	弹簧垫圈	WASHER, LOCK	1	
04	206963	7	滤清器连接接头	ADAPTER, FILTER HEAD	1	
04	3008466	8	管塞	PLUG, PIPE	1	
04	3008469	9	管塞	PLUG, PIPE	1	
04	3010181	10	进水接头	CONNECTION, WATER INLET	1	
04	3010536	14	截断阀轴	SHAFT, SHUTOFF VALVE	1	
04	3010784	11	输水管	TUBE, WATER TRANSF	1	
04	3201982	12	阳性接头	CONNECTOR, MALE	1	
04	3201983	13	阳性接头	CONNECTOR, MALE	1	
04	3818885	15	O型密封圈	SEAL, O RING	1	
03	3010596	16	带垫螺栓	SCREW, CAPTIVE WAS	3	
03	3012472	17	带垫螺栓	SCREW, CAPTIVE WAS	1	
03	3012474	18	带垫螺栓	SCREW, CAPTIVE WAS	1	
03	3036096	29	水泵支撑	SUPPORT, WATER PUMP	1	
03	3098961		水泵	PUMP, WATER	1	
04	3165998	19	放水开关	DRAINCOCK	1	
04	S 16062	20	滚珠轴承	BEARING, BALL	1	
04	S 16069	21	滚珠轴承	BEARING, BALL	1	
04	70183	22	卡环	RING, RETAINING	1	
04	205243	28	水泵叶轮	IMPELLER, WATER PUMP	11	
04	205258	23	卡环	RING, RETAINING	1	
04	206948	24	油封	SEAL, OIL	1	
04	206964	25	水泵体	BODY, WATER PUMP	1	
04	3042827	27	水泵轴	SHAFT, WATER PUMP	1	
05	205158		水泵轴	SHAFT, WATER PUMP	1	
05	3040833		水泵轴	SHAFT, WATER PUMP	1	
04	3609826	26	水泵水封	SEAL, WATER PUMP	1	

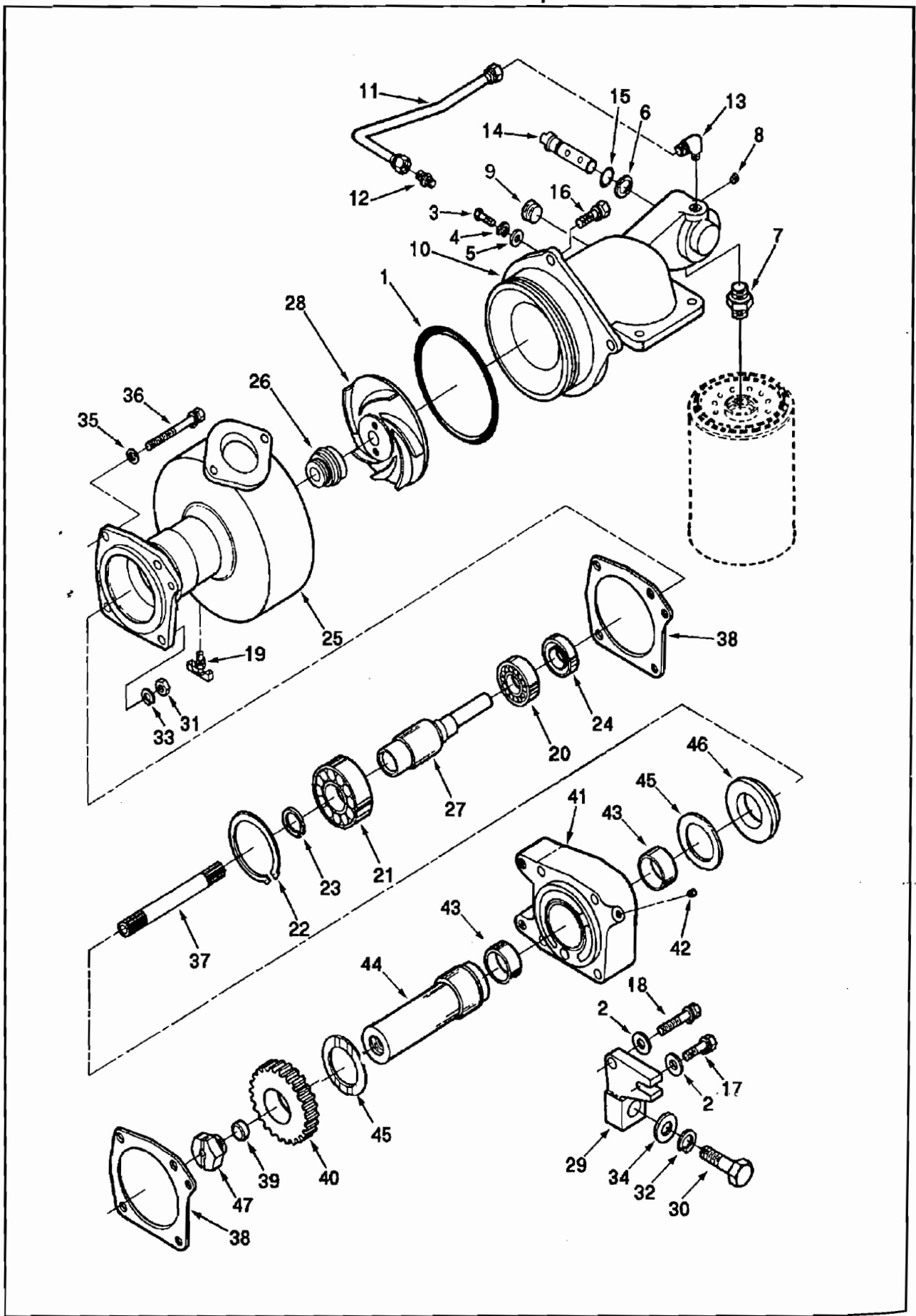

级别 LV	零件号 Part Number	图上标号 Ref No	零件名称 Part Name		数量 Req	备注 Remarks
			中文	英文		
02	3088377		水泵安装	PUMP, WATER MTG	1	
03	S 602	35	平垫圈	WASHER, PLAIN	3	
03	3012476	36	带垫螺栓	SCREW, CAPTIVE WAS	3	
03	3202007	37	水泵轴	SHAFT, WATER PUMP	1	
03	3202283	38	水泵衬垫	CASKET, WATER PUMP	2	
03	S 103 A	30	六角螺栓	SCREW, HEXAGON HEAD	1	
03	S 205	31	六角螺母	NUT, REGULAR HEXAGON	1	
03	S 603	32	弹簧垫圈	WASHER, LOCK	1	
03	S 604	33	弹簧垫圈	WASHER, LOCK	1	
03	S 658	34	平垫圈	WASHER, PLAIN	1	
02	3200968		螺塞	PLUG, THREADED	1	
02	3410054		水泵轴	SHAFT, WATER PUMP	1	
03	205498	39	油塞	PLUG, OIL	1	
03	207251	40	水泵齿轮	GEAR, WATER PUMP	1	
03	3025887	44	水泵轴	SHAFT, WATER PUMP	1	
03	3026556	45	止推轴承	BEARING, THRUST	2	
03	3034721	46	水泵轴轴用卡环	RETAINER, SHAFT	1	
03	3086177		水泵支撑	SUPPORT, WATER PUMP	1	
04	205156	43	衬套	BUSHING	2	
04	3056416		螺塞	PLUG, THREADED	1	
05	3056003		螺塞	PLUG, THREADED	1	
05	3056415		O型密封圈	SEAL, O RING	1	
04	3086178	41	水泵支撑	SUPPORT, WATER PUMP	1	

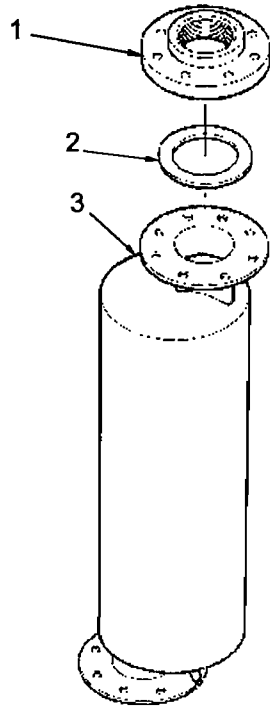

级别 LV	零件号 Part Number	图上标号 Ref No	零件名称 Part Name		数量 Req	备注 Remarks
			中文	英文		
02	3165922		六角螺栓	SCREW, HEXAGON HEAD CAP	8	适用于: KTA19-G2(M) /G3(M)
02	3165930		六角螺栓	SCREW, HEXAGON HEAD CAP	24	
02	3165937		六角螺母	NUT, LOCK	8	
02	3165941		六角螺母	NUT, LOCK	24	
02	3165966		平垫圈	WASHER, PLAIN	8	
02	3165970		平垫圈	WASHER, PLAIN	24	
02	3165976		弹簧垫圈	WASHER, LOCK	8	
02	3165981		弹簧垫圈	WASHER, LOCK	24	
02	3418930	1	消声器总成	ASSY, MUFFLER	1	
02	3418939		衬垫	GASKET	3	
02	3418944		弯管接头	CONNECTIOR, TUBE	1	
02	3418954		锥度接头	CONNECTION	1	
02	3419000		衬垫	GASKET	1	

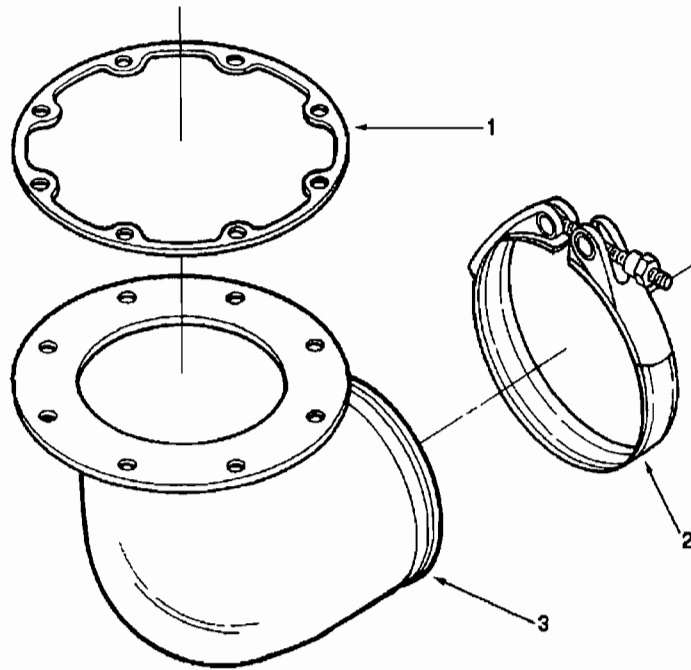

级别 LV	零件号 Part Number	图上标号 Ref No	零件名称 Part Name		数量 Req	备注 Remarks
			中文	英文		
02	106322	1	衬垫	GASKET, TURBOCHARGER	1	
02	3026447		增压器管接头	CONNECTION, TURBO	1	
03	201989	2	V型带卡箍	CLAMP, V BAND	1	
03	3026237	3	排气管接头	CONN, EXHAUST OUTLET	1	

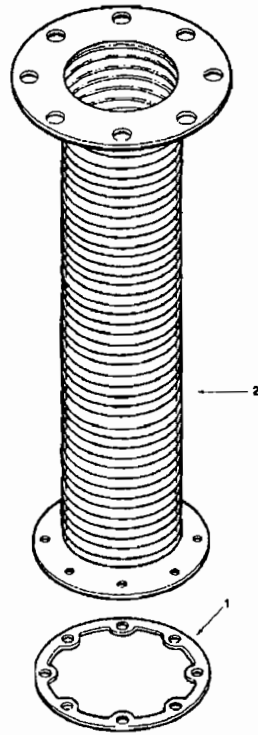

级别 LV	零件号 Part Number	图上标号 Ref No	零件名称 Part Name		数量 Req	备注 Remarks
			中文	英文		
02	106322	1	衬垫	GASKET ,TURBOCHARGER	1	
02	203555	2	排气波纹管	CONNECTION, EXHAUST OUTLE	1	

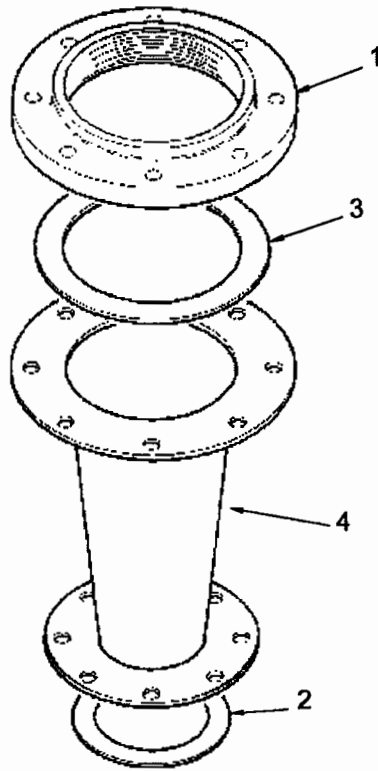

级别 LV	零件号 Part Number	图上标号 Ref No	零件名称 Part Name		数量 Req	备注 Remarks
			中文	英文		
02	119904	1	排气接头	ADAPTER, EXHAUST OUTLET	1	适用于: KTA19-G4 (M)
02	3036377	2	对垫	GASKET, FLANGE	1	
02	3036378	3	对垫	GASKET, FLANGE	1	
02	3036381	4	排气连接管	CONNECTION, EXHAUST OUTLET	1	

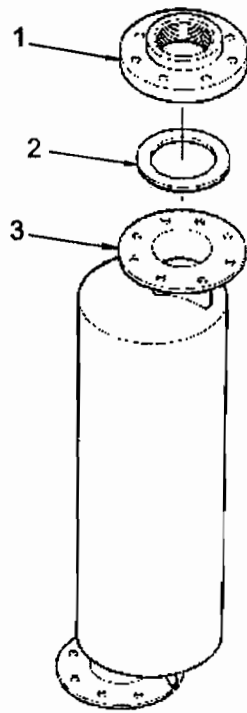

级别 LV	零件号 Part Number	图上标号 Ref No	零件名称 Part Name		数量 Req	备注 Remarks
			中文	英文		
02	3055653	1	排气消声器	ASSY, MUFFLER	1	适用于: KTA19-G4(M)

地址: 重庆市沙坪坝壮志路(烈士墓)

电话: 023-65335888(总机)

023-65333444(服务热线)

电报: 0221(重庆)

传真: 023-65315379

邮编: 400031

零件号: 3166165-01

CCEC 文印中心印刷

ADD: ZHUANGZHI ROAD, SHAPINGBA, CQ

PHONE: 023-65335888

023-65333444

CABLE: 0221(CQ)

FAX: 023-65315379

P.C: 400031

PARTS NO: 3166165-01

