



NTA855-G 零件图册

NTA855-G PARTS CATALOG

发电机组配套

零件号: 3166120 Rev00

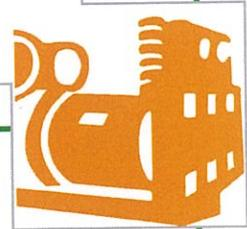
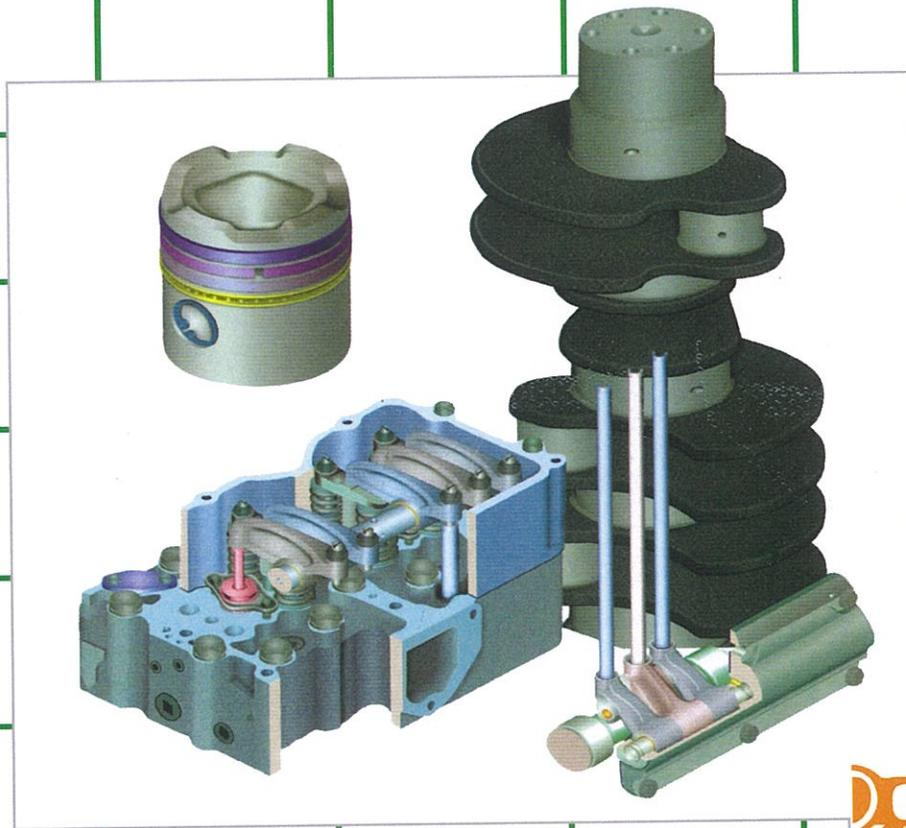

重庆康明斯发动机有限公司
CHONGQING CUMMINS ENGINE COMPANY Ltd.



3166120-20, 1

《N系列发动机零件图册》

使用 说 明

此图册是按N系列发动机增压和增压中冷机型的几个标准型绘编的,它以直观的形式显现出了发动机的易损零件和一般零件。由于N系列发动机有较好的零件通用性,故这本图册将是用户选购零部件指导性的资料。

随着发动机的不断改进,图册零件号和实际零件号可能不一致,请用户在选购零件时提供以下情况:

一、发动机名牌或合格证上的机型和生产指令号(S.O)、以及发动机出厂序号。

二、写明图册中的图册零件号(最好注明页次)。

我厂可根据用户提供的以上资料,查到对应的实际零件号。

用户在使用此图册过程中,如有问题,可随时向我厂提出,我公司会作出尽快的答复。

重庆康明斯发动机有限公司

二〇〇〇年六月

Instruction

The catalog is compiled according to several standard models of N series engine turbocharged,turbocharged and after cooled. It' s very easy for you to find what kinds of engine parts to be ordered and replaced.Since N series engine has a high commuality,the catalog is guideline for our customers to order the parts he/She wants.

With improvements on the engines were producing,the part No.in the catalog may be different from that in present production.

The following information will be supplied when you order the parts.

* Engine model and shop order NO.(s.o.)on the nameplate of your engine or the certiifiicate,and the series NO. of engine.

** The exact part No.in the catalog (It' s better to put down the page NO. in the catalog).

We can find out the present part No. upon your correct inforrmation,then we' ll take prompt actoin to resolve your problems.

Chongqing Cummins Engine company Ltd.

Dec. 2000

目 录 Table of Contents

标 题	Title	页 数 Page No.
气缸体	Cylinder Block	1
曲轴、减振器及皮带轮	Crankshaft, Engine Damper, Vibration and Pulley	3
活塞、连杆总成	Piston and Connrod	4
凸轮轴	Camshaft	5
发动机前支架	Front Engine Support	6
齿轮室盖	Gear Cover	6
气缸盖	Cylinder Head	8
凸轮轴后动件及推杆	Cam Follower Housing and Push Rod	8
摇臂室	Rocker Housing	10
机油冷却器	Lub Oil Cooler	12
机油盘	Oil Pan	15
机油泵	Lub Oil Pump	16
风扇轮毂及风扇	Hub Fan and Fan	18
水泵	Water Pump	20
节温器壳及水管	Thermostat Housing and Water Manifold	22
中冷器	Air Intercooler	24
进气管	Air Intake Manifold	26
排气管	Exhaust Manifold	27
增压器及安装	Turbocharger and Mtg	28
增压器进回油管	Turbocharger Plumbing	30
附件驱动	Accessory Drive	31
燃油泵	Fuel Pump	32
喷油器	Injector	34
发电机	Alternator	35
水滤器	Corrosion Resistor	36
飞轮、飞轮壳	Flywheel and Flywheel Housing	37
起动机	Starting Motor	38
燃油滤清器	Fuel Filter	39
仪表盘	Instrument Panel	40
水箱	Radiator	41
旁通滤清器	Lub Oil Filter Element	42

图-1 气缸体



表-1

级别	零件号	图上 标号	零 件 名 称		数量	备 注
			中 文	英 文		
02	3032187		气缸体组件	BLOCK CYLINDER	1	
03	67211	28	主轴承定位销	DOWEL, REAR MAIN BEARING	2	
03	68585	26	定位销	DOWEL, PIN	6	
03	3039305	36	垫圈	WASHER, PLAIN	14	
03	208346	35	六角螺栓	SCREW, HEXAGON HEAD	14	
03	3008047	34	主轴承盖	CAR, MAIN BEARING(1#, 3#, 5#)	3	
03	3008048	31	主轴承盖	CAR, MAIN BEARING(2#, 4#, 6#)	3	
03	3008049	30	主轴承盖	CAR, MAIN BEARING(7#)	1	
03	3011951	2	衬套	BUSHING(7#)	1	
03	3028075	1	衬套	BUSHING(1#, 2#, 4#, 6#)	4	
03	3028269	3	衬套	BUSHING(3#, 5#)	2	
03	3031150	21	气缸体	BLOCK CYLINDER	1	
02	AR9759		气缸套组件	LINER, CYLINDER	6	
03	3055099	5	气缸套	LINER, CYLINDER	6	
03	215090	7	缝隙密封圈	SEAL, DREVICE	6	
03	3032874	10	O型密封圈	SEAL, O RRING	6	
03	3032874	9	O型密封圈	SEAL, O RING	6	
02	MP5346		气缸体安装	MTG, CYLINDER BLOCK	1	

续表-1

级别	零件号	图上 标号	零件名称		数量	备注
			中文	英文		
03	S966E	20	锥型螺塞(1 1/2")	PLUG,PIPE(1 1/2")	1	
03	66292	32	平垫圈	WASHER,PLATE	1	
03	68445	4	槽销	PIN,GROOVE	6	
03	69901		锥型螺塞(1/8")	PLUG,PIPE(1/8")	7	
03	202903	29	圆形销	PIN,ROLL	2	
03	210884		锥型螺塞(7/8")	PLUG,PIPE(7/8")	1	
03	3008466	16	锥型螺塞(1/4")	PLUG,PIPE(1/4")	1	
03	3011952	23	碗形塞	PLUG,EXPENSION	1	
03	3008468	27	锥型螺塞(1/2")	PLUG,PIPE(1/2")	3	
03	3013786	22	锥型螺塞(3/8")	PLUG,PIPE(3/8")	3	
02	3014404		活塞冷却喷咀组件	NOZZLE,PISTON COOLING	6	
03	3013591	14	活塞冷却喷咀	NOZZLE,PISTON COOLING	6	
04	3007442	15	O型密封圈	SEAL O RING	6	
04	3013590		喷咀	NOZZLE	6	
03	3033822	13	带垫螺栓	SCREW,CAPTIVE WASHER	6	
02	AR10070		总水管盖	COVER,WATER HEADER	1	
03	70089-1	19	盖板垫片	GASKET,COVER PLATE	1	
03	132019	18	总水管盖	COVER,WATER HEADER	1	
03	3013904	17	带垫螺栓	SCREW,CAPTIVE WASHER	6	
02	3418684		气缸盖及安装	MTG,CYLINDER HEAD	1	
03	3013623	6	气缸盖螺栓	SCREW,HEXAGON HEAD	36	
03	69699	8	垫圈	WASHER,PLAIN	36	
03	60408	24 37	定位销	DOWWEL PIN	3	
03	70653	38	定位销	DOWEL PIN	1	

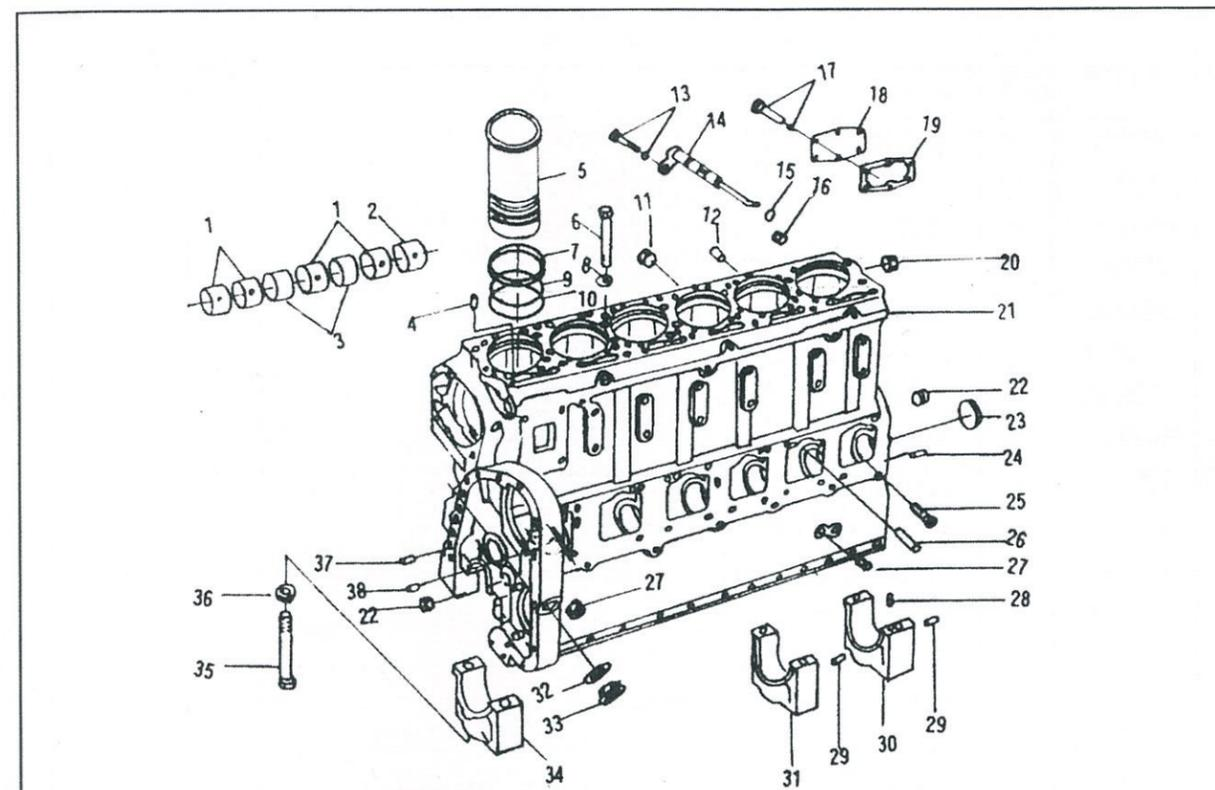
图-2 曲轴、减振器及皮带轮



表-2

级别	零件号	图上 标号	零件名称		数量	备注
			中文	英文		
02	3511727	1	硅油减振器	DAMPER,VIBRATION	1	
02	211918	2	曲轴皮带轮	PULLEY,CRANKSHAFT	1	
02	3037046		主轴瓦组	SET,MAIN BEARING	1	
03	3019174	3	轴瓦(1,3,5上)	BEARING,MAIN	3	
03	3019186	4	轴瓦(2,4,5上)	BEARING,MAIN	3	
03	3019198	5	轴瓦(7上)	BEARING,MAIN	1	
03	3019192	6	轴瓦(2,4,5下)	BEARING,MAIN	3	
03	3019204	7	瓦(7下)	BEARING,MAIN	1	
03	3019180	8	轴瓦(1,3,5下)	BEARING,MAIN	3	
03	3067568	9	止推片	BEARING,THRUST	4	
03	202903	10	止推环销钉	PIN,ROLL	2	
03	3037045	11	主轴瓦定位环	RING,MAIN BEARING	7	
03	210179	12	齿轮键	KET,RECTANGULAR	1	
03	3014614	13	曲轴齿轮	GEAR,CRANKSHAFT	1	
03	204165	14	自锁螺钉	SCREW,HEAD LOCKING	6	
03	127316	15	垫片	WASHER,PLAIN	6	
03	3418949	16	曲轴	CRANKSHAFT,ENGINE	1	
02	3419348		曲轴总成	CRANKSHAFT	1	

图-3 连杆、活塞、活塞环

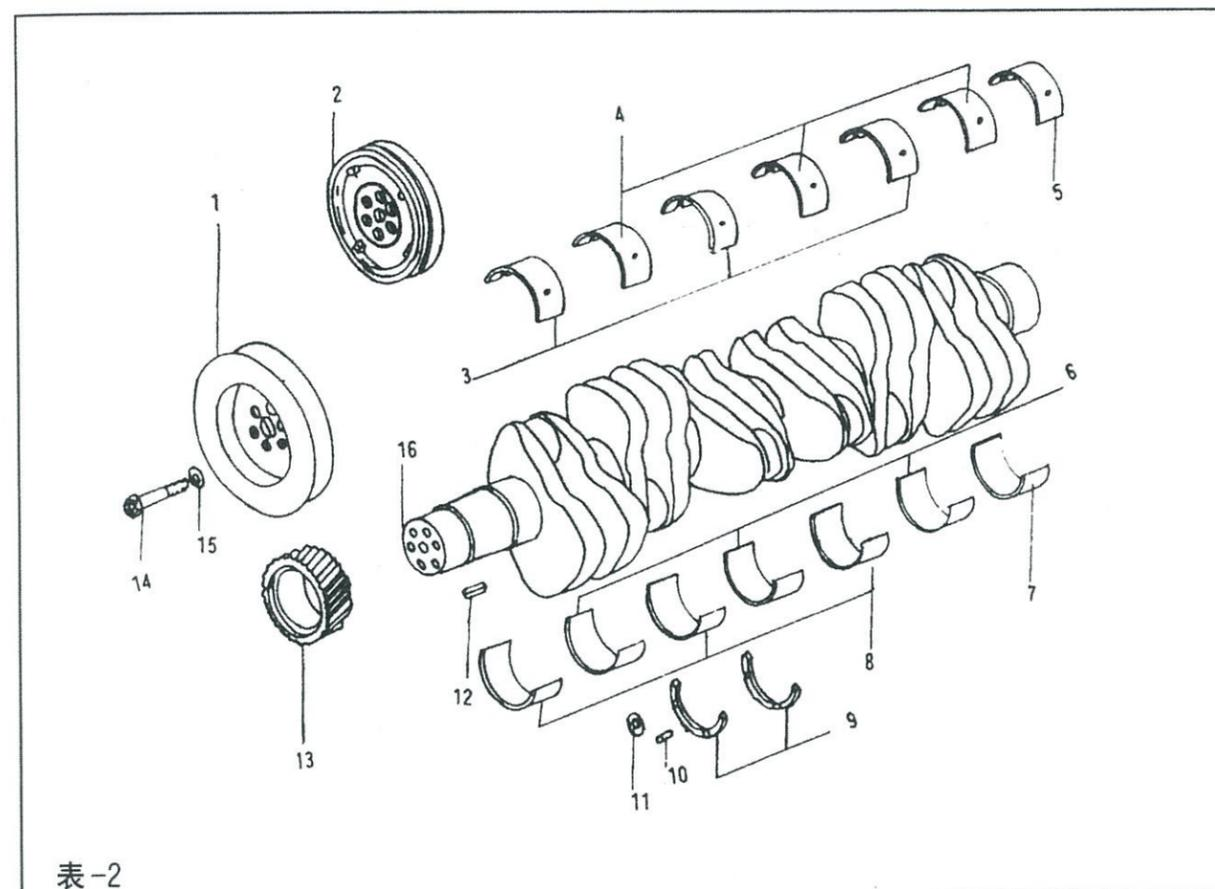

表-3

级别	零件号	图上标号	零件名称		数量	备注
			中文	英文		
02	3022156		活塞及连杆总成	PISTON and CONNROD	6	
03	3013930	3	连杆总成	ROD ENGINE CONNEECTION	6	
04	70550	4	定位销	DOWEL PIN	12	
04	187420	1	连杆衬套	BUSHING	6	
04	218808	3	连杆	ROD.ENGINE CONNECTION	6	
04	219153	5	连杆螺栓	BOLT,CONNECTING ROD	12	
03	214950	2	连杆轴瓦	BEARING,CONNECTING	12	
03	3017349	12	活塞总成	PISTON,ENGINE	6	
03	191970	11	活塞销	PIN PISTON	6	
03	175755	10	卡环	RING,REATING	12	175755
03	218025	6	压缩环	RING,COMPRESSION	6	3012331
03	3012332	7	压缩环	RING,COMPRESSION	6	
03	3056429	8	压缩环	RING,COMPRESSION	6	
03	3082580	9	油环	RING OIL PIISTON	6	

*注:连杆轴瓦可购大0.010" .0.020" .0.030" AND0.040"

*NOTE:THE BEARING CONNECTING CAN BUY BIG 0.010" .0.020" .0.030" and0.040

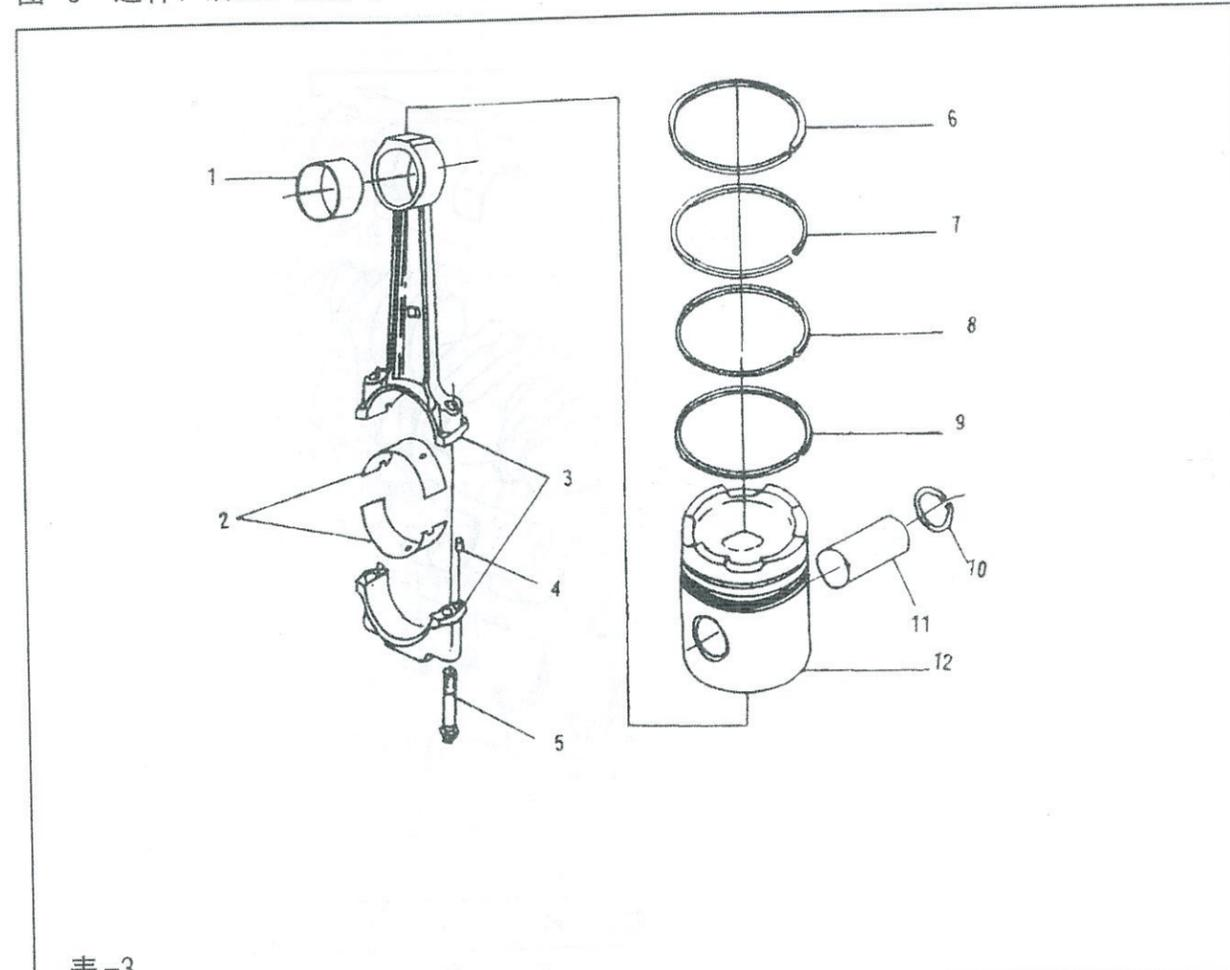
图-4 凸轮轴及曲轴后油封



表-4

级别	零件号	图上标号	零件名称		数量	备注
			中文	英文		
02	3049032		凸轮轴	CAMSHAFT		
03	68193	1	管塞	PLUG.PIPE	1	
03	3002901	2	凸轮轴转动齿轮	GEAR.CAMSHAFT	1	
03	3021600	3	键	KEY.OFFSET WOODRUFF	1	
03	3042568	4	凸轮轴	CAMSIAFT	1	
02	215233	5	止推轴承	BEARING.THRUST	1	
02	ARI0833		后盖板总成	PLATE.REAR COVER		
03	209919	8	后盖板	PLATE.REAR COVER	1	
03	211253	7	曲轴后油封	SEAL.OIL	1	
02	MP4314		后盖板安装	PLATE.REAR COVER MTG	1	
03	40662A	9	后盖板垫片	GASKET.REAR COVER	1	
03	3010594	6	带垫螺栓	SCREW,CAPTIVE WAS	8	

图-5 发动机前支架

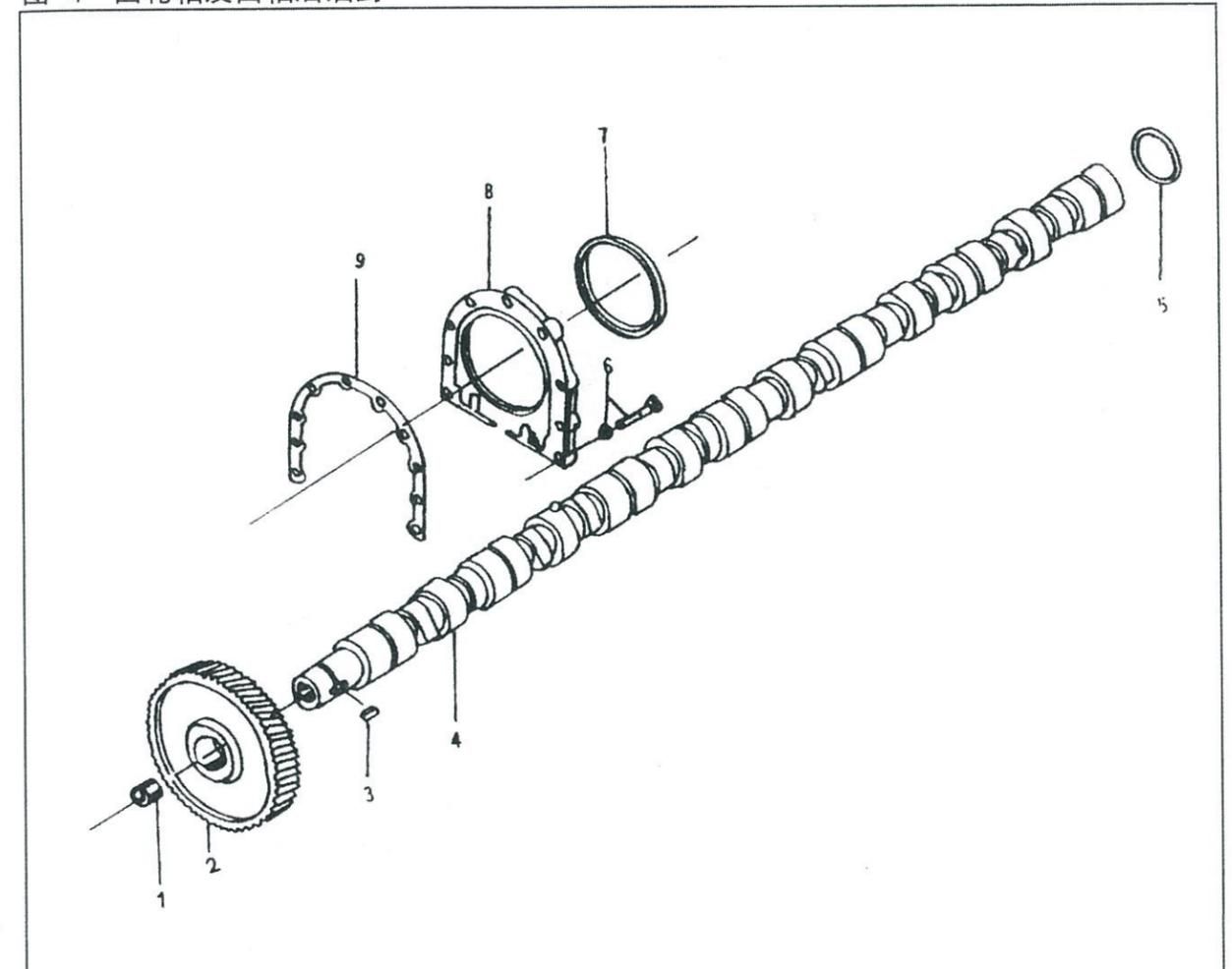

图-6 齿轮室盖



表-5

级别	零件号	图上标号	零件名称		数量	备注
			中文	英文		
03	3058664	1	十二角螺栓	SCREW.TWELVE POINT CAP	1	
03	3054889	2	六角螺栓	SCREW,HEXAGON HEAD	4	
03	3600283	3	平垫圈	WASHER PLAIN	2	
03	3000082	4	平垫圈	WASHER PLAIN	4	
03	3419063	5	发动机前支架	SUPPORT.FRONT ENGINE	1	
03	3600285	6	六角螺栓	SCREW HEXAGON HEAD	2	

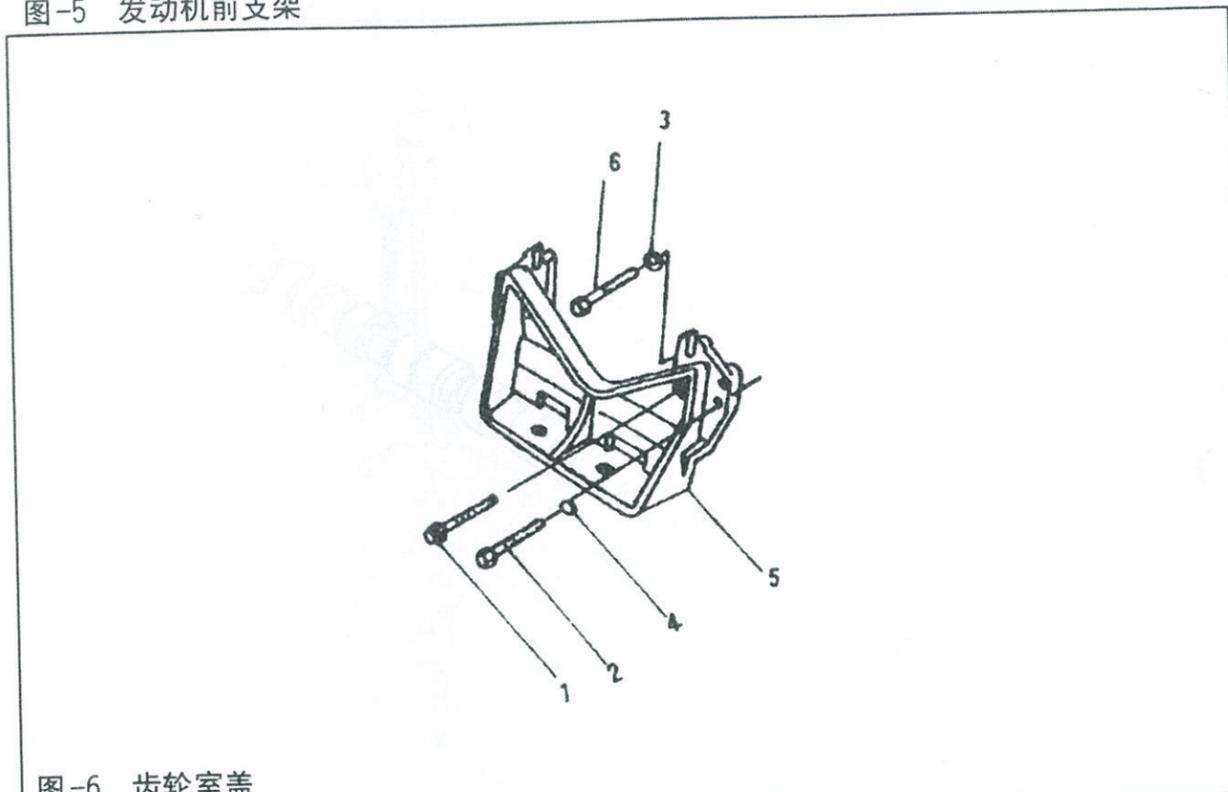
表-6

级别	零件号	图上标号	零件名称		数量	备注
			中文	英文		
03	132770	1	衬套	BUSHING	1	
02	3020185	2	附件驱动轴油封	SEAL.OIL	1	
02	3008530	3	凸轮轴支承座	SUPPORT,CAMSHAFT THRUST	1	
03	65259A	4	调整垫片	SHIM	1	
03	65259B	4	调整垫片	SHIM	1	
03	65259C	4	调整垫片	SHIM	1	
03	185573	4	调整垫片	SHIM	1	
03	215705	5	O型密封圈	SEAL.O RING	1	
03	3011715	6	带垫螺栓	SCREW,CAPTIVE WAS	3	
03	3011713	7	带垫螺栓	SCREW,CAPTIVE WAS	1	
03	S911B	8	管塞	PLUG.PIPE	1	
03	3011714	9	带垫螺栓	SCREW,CAPTIVE WAS	3	
02	3020186	10	曲轴前油封	SEAL.OIL	1	
03	S622	11	垫圈	WASHER	4	
03	185804	12	六角螺栓	SCREW,HEXAGON HEAD CAP	4	
03	3011712	13	带垫螺栓	SCREW,CAPTIVE WAS	9	
03	3418659	14	正时齿轮室盖	COVER GEAR	1	
03	60408		定位销	DOWEL.PIN	1	
03	3008466	16	管塞	PLUG.PIPE	1	
03	3021704	17	垫片	GASKET,GEAR COVER	1	
03	3013786		管塞	PLUG.PIPE	1	
03	S610	18	弹簧垫圈	WASHER.LOCK	4	
03	70653	15	定位销	DOWEL.PIN	1	

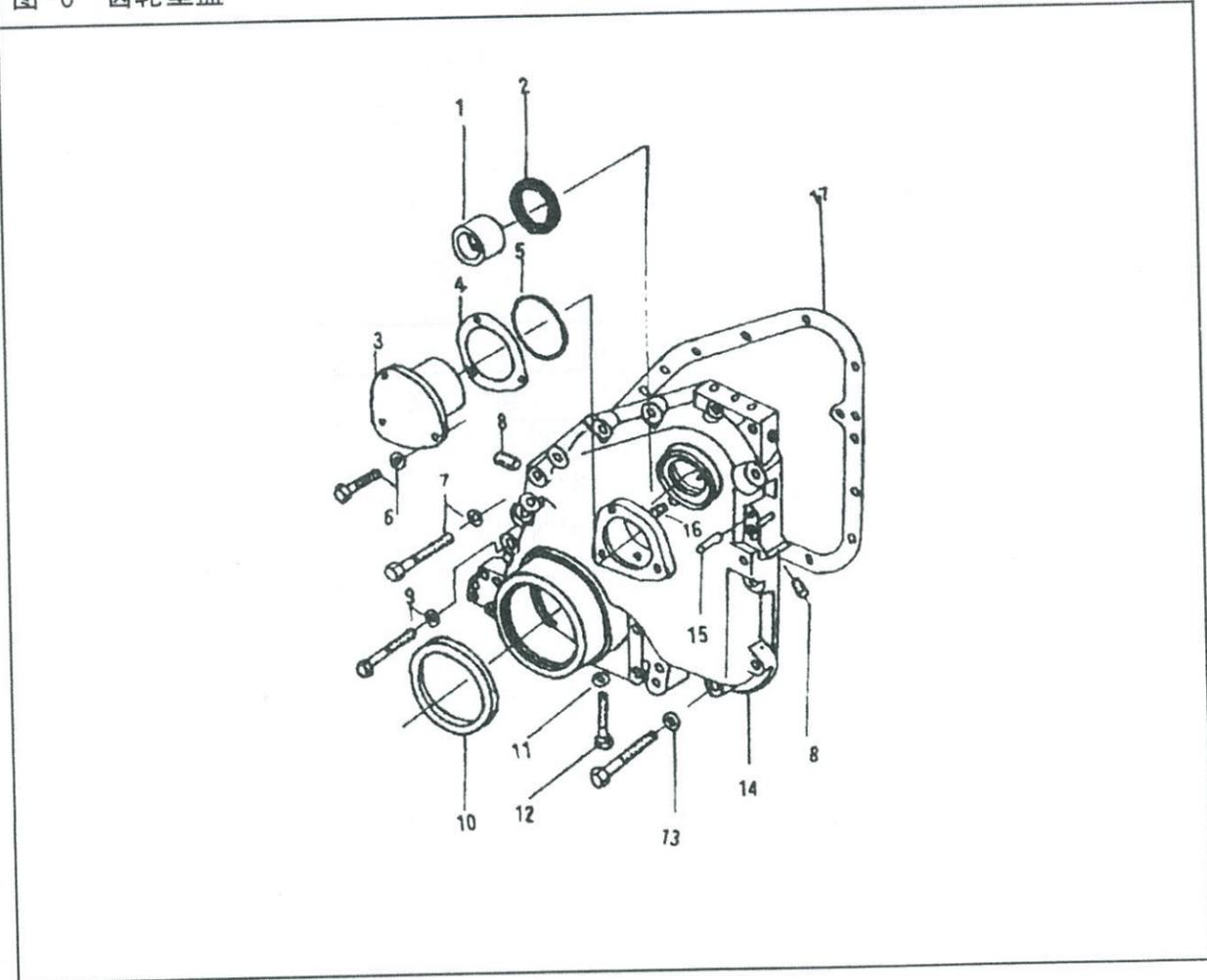
图-7 气缸盖总成



图-8 凸轮轴从动件及推杆



表-7

级别	零件号	图上 标号	零件名称		数量	备注
			中文	英文		
02	3027340		气缸盖及安装	HEAD,CYLINDER	3	
03	69699	9	平垫圈	WASHER,PLAIN	36	
03	3013623	8	六角螺栓	SCREW,HEXAGON HEAD	36	
03	3418529	20	气缸盖总成	HEAD,CYLINDER	3	
04	S911B		管塞	PLUG,PIPE	15	
04	127554	10	气门锁夹	COLLET,VALVE	48	
04	170296	11	气门弹簧上座	GUIDE,VALVE SPRING	24	
04	211999	12	气门弹簧	VALVE SPRING	24	
04	3042745	13	气门弹簧下座	GUIDE,VALVE SPRING	24	
04	145701	23	排气门	VALVE,EXHAUST	12	
04	135957	23	进气门	VALVE,INTAKE	12	
04	3418678		气缸盖	HEAD,CYLINDER	3	
05	67861	3	螺塞	PLUG,PIPE	3	
05	123558	4	丁字压板道杆	GUIDE,VALVE CROSSHEAD	12	
05	3011934	16	喷咀铜套	STEEVE,INJECTOR	6	
05	127930	22	排气门座圈	INSERT,VALVE EXHAUST	12	
05	200354	22	进气门座圈	INSERT,INTAKE VALVE	12	
05	3006456	14	气门导管	GUIDE,VALVE STEM	24	
05	3007716		气缸盖	HEAD,CYLINDER	3	
05	3418657		螺塞	PLUG,PIPE	3	
05	3007759	15	O型密封圈	SEAL,O RING	6	
05	3008469	21	螺塞	PLUUG,PIPE	18	
05	3008470	3	螺塞	PLUG,PIPE	6	
03	3047402	2	气缸垫	GASKET,CYLINDER HEAD	3	
02	3030038		丁字压板	CROSS HEAD	12	
03	147389	6	调整螺栓	SCREW	12	
03	203131	7	螺母	NUT,HEAVY HEXAGON	12	
03	3028293	5	丁字压板	CROSSHEAD,VALVE	12	
03	70772	17	螺钉	SCREW,FILH SPRING	12	
03	147100	18	燃油跨管	CROSS OVER,FUEL	2	
03	131026	19	O型圈	SEAL,O RING	12	

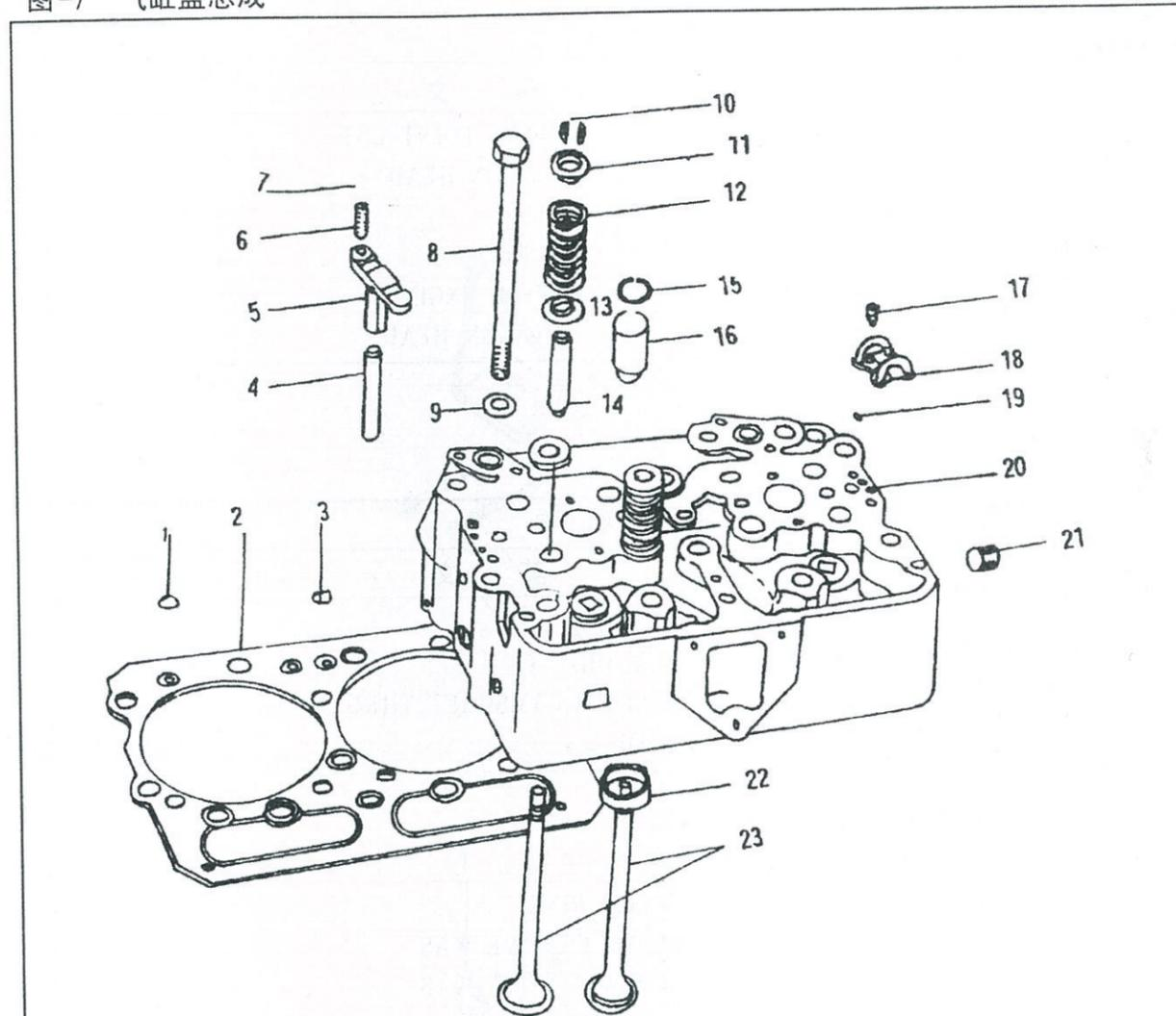
表-8

级别	零件号	图上 标号	零件名称		数量	备注
			中文	英文		
02	3418754	1	气门推杆	ROD,PUSH	12	
02	3418755	2	喷咀推杆	ROD,PUSH	6	
03	3074400	3	调整垫	GASKET	6	
03	3074401	3	调整垫	GASKET	6	
03	3074402	3	调整垫	GASKET	6	
03	3074403	3	调整垫	GASKET	6	
03	68585	4	定位销	DOWEL,PIN	6	
02	3418660	5	凸轮后动室总成	HOUSING,CAM FOLLOWER	13	
03	S129	6	六角螺栓	SCREW,HEXAGON HEAD	18	

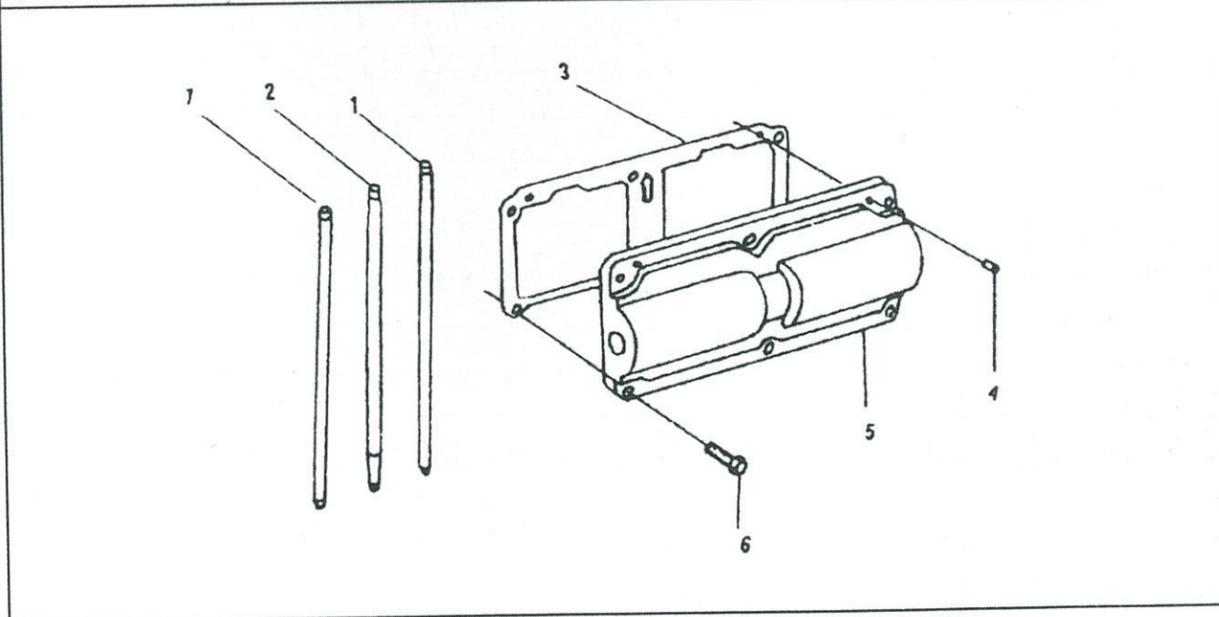
图-9 摇臂室、盖及曲轴箱通风



表-9

级别	零件号	图上标号	零件名称		数量	备注
			中文	英文		
02	3418522		摇臂室总成	ROCKER HOUSING	3	
03	3418523		喷油摇臂	LEVER,ROCKER	6	
04	S-212	20	六角厚螺母	NUT,REGULAR HEXAGON	6	
04	168306	19	带槽调整螺栓	SCREW SIOTTED	6	
04	3418540	25	喷油摇臂分总成	LEVER ROCKER	6	
05	194037	16	摇臂凹头(球窝)	SOCKET,ROCKER LEVER	6	
05	218153	18	喷油摇臂衬套	BUSHING	6	
05	3418511	25	喷油摇臂	LEVER,ROCKER	6	
03	3418527		后摇臂总成	LEVER,ROCKER REAR	6	
04	S-212	20	六角厚螺母	NUT,REGULAR HEXAGON	6	
04	168306	19	带槽调整螺栓	SCREW,SLOTTED	6	
04	3418538	14	后摇臂分总成	LEVER,ROCKER,REAR	6	
05	140330	15	摇臂衬套	BUSHING	6	
05	208084		铆钉	RIVET	6	
05	3655786	14	后摇臂	LEVER,ROCKER REAR	6	
03	3418528		前摇臂总成	LEVER,ROCKER FRONT	6	
04	S-212	20	六角厚螺母	NUT,REGULAR HEXAGON	6	
04	168306	19	带槽调整螺栓	SCREW,SLOTTED	6	
04	3418539	27	前摇臂分总成	LEVER,ROCKER FRONT	6	
05	140330	15	摇臂衬套	BUSHING	6	
05	208084		铆钉	RIVET	6	
05	3655785	27	前摇臂	LEVER,ROCKET FRONT	6	
03	3038904	30	摇臂轴	SHAFT,ROCKER LEVER	3	
03	3038903	28	摇臂轴堵塞	PLUG ROCKER LEVER	6	

续表-9

级别	零件号	图上标号	零件名称		数量	备注
			中文	英文		
03	3000521	29	O型密封圈	SEAL,O RING	6	
03	168319	31	摇臂轴固定螺栓	SET,SCREW	3	
03	3418752	33	摇臂室	HOUSING,ROCKER LEVER	3	
02	3012238		摇臂室安装	COVER,ROCKER MOUNTING	3	
03	3010589	32	带垫螺栓	SCREW,CAPTIVE WASHER	18	
03	3017750	34	摇臂室衬垫	GASKET,RKR LEVER HOUSING	3	
02	3006183	8	中摇臂室盖	COVER,ROCKER LEVER	1	
02	3006349	1	前摇臂室盖	COVER,ROCKER LEVER FRONT	1	
03	3006358	4	后摇臂室盖总成	COVER,ROCKER LEVER REAR	1	
02	MP3887		摇臂室盖安装	COVER,ROCKER LEVER HOUSING MTG	2	
03	3038076	3	带垫螺栓	SCREW,CAPTIVE WASHER	10	
03	3067459	26	摇臂室盖衬垫	GASKET,ROCKER LEVER COVER	2	
02	3010847		摇臂室盖安装	COVER,RKR HSG MTG	1	
03	63385		隔套	SPACER,WATER CONN	3	
03	108707		带垫螺栓	CAPTTVE SCREW WASHER	1	
03	3038076		带垫螺栓	SCREW,CAPTIIVE WASHER	4	
03	3067459	26	摇臂室盖衬垫	GASKET,ROCKER LEVER COVER	1	
02	AR7328		通风管	TUBE VENT	1	
03	S-205		六角螺母	NUT,REGULAR HEXAGON	1	
03	S-604	12	弹簧垫圈	WASHER,LOCK	1	
03	43828	6	软管卡箍	CLAMP,HOSE	2	
03	64775	7	软管	HOSE,PLAIN	1	
03	69911A	10	夹子	CLIP	1	
03	69793	13	六角螺栓	SCREW,HEXAGON HEAD	1	
03	111670		机油尺道管支撑	SUPPORT,OIL GAUGE TUBE	1	
03	142486	9	通风管	TUBE,BREATHER	1	
02	255180	5	曲轴箱通风器	BREATHER,CRANKCASE	1	
02	3418519	2	加机油口盖总成	COVER,OIL FILLER	1	
03	AR6059		前起吊支架总成	BRACKET,LIFTING FRONT	1	
03	S-176	22	六角螺栓	SCREW,HEXAGON HEAD	2	
03	170226	17	前起吊支架	BRACKET,LIFTING FRONT	1	
03	AR13190		后起吊支架总成	BRACKET,LIFTING REAR	1	
03	S-176	22	六角螺栓	SCREW,HEXAGON HEAD	2	
03	3001726	17	后起吊支架	BRACKET,LIFTING REAR	1	

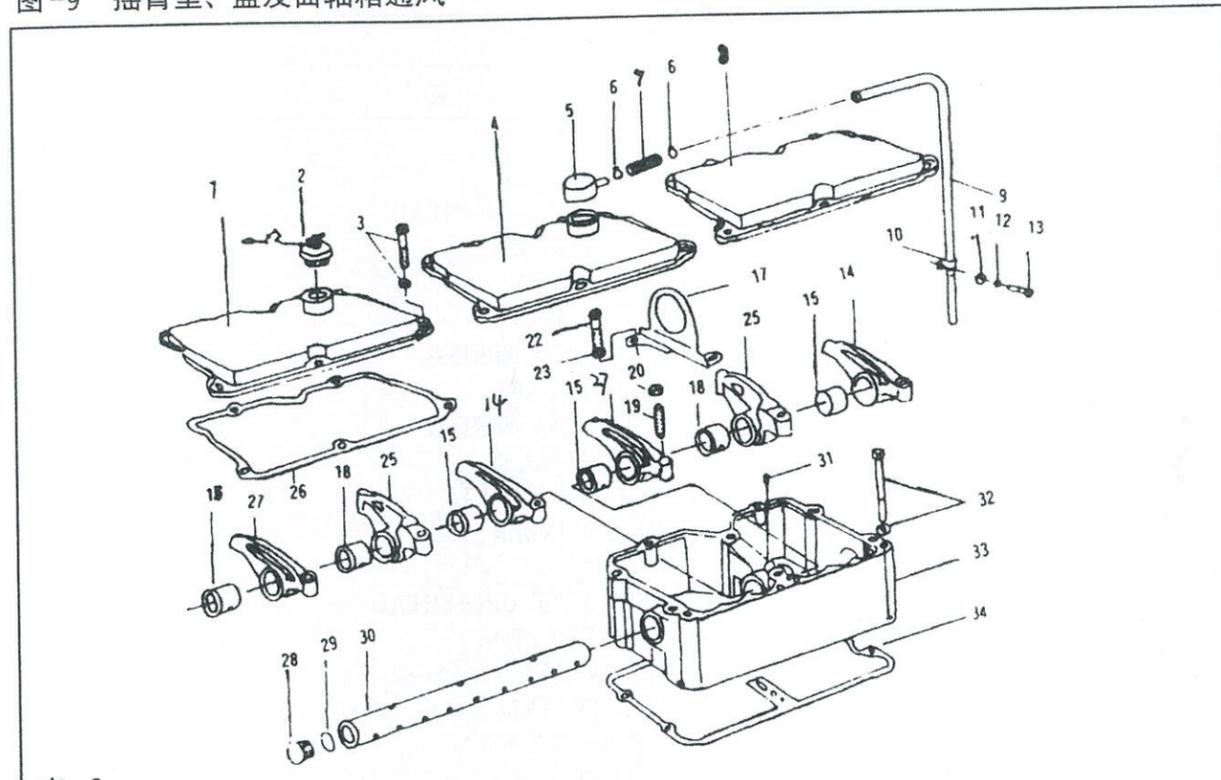
图-10 机油冷却器



表-10

级别	零件号	图上 标号	零件名称		数量	备注
			中文	英文		
02	3003814		机油冷却器总成	KIT.LUB OIL COOLER ASSEMBLY	1	
03	AR9999		机油冷却器	KIT.LUB OIL COOLER	1	
04	202128	24	弹簧	SPRING.COMPRESSION	1	
04	210915	18	壳体	HOUSING.OIL FILTER COOLER	1	
04	3006745	22	档圈	RING.RETAINING	2	
04	3007713	19	O型密封圈	SEAL. O-RING	2	
04	3008466	20	管塞	PLUG.PIPES	1	
04	3013786	12	管塞	PLUG.PIPES	1	
04	3018673	16	旁通阀件	DISC.VALVE	1	
04	208149	17	冷却器芯	CORE.COOLER	1	
04	3023994	23	档塞	PLUG.RETAINER	1	
04	3025458	21	管塞	PLUG.PIPES	1	
03	S104	3	螺栓	SCREW HEXAGON HEAD CAP	1	
04	S126	9	螺栓	SCREW.HEXAGON HEAD CAP	1	
04	S603	3	弹簧垫圈	WASHER.LOCK	2	
04	S604	1	弹簧垫圈	WASHER.LOCK	1	
04	67946	6	平垫圈	WASHER.PLAIN	1	
03	68274	14	弹簧	SPRING.COMPRESSION	1	
03	108307	10	放水开关	DRAINCOCK	1	
03	127558	13	调压柱塞	PLUNGER.PRESSURE REGULATOR	1	
03	3418751	63	螺栓	SCREW.HEXAGON HEAD CAP	1	(或 138045)
03	213394	68	碗形塞	PLUG.EXPANSION	1	(或 142110)
03	173368	66	密封圈	SEAL.RECTANGULAR RING	1	(或 3302630)
03	200861	64	平垫圈	WASHER.PLAIN	1	
03	210967	15	机油冷却器支座	SUPPORT.OIL COOLER	1	
03	217315	5	机油冷却器盖	COVER.LUB OIL COOLER	1	
03	218245	7	垫片	GASKET.LUB OIL COOLER COVER	1	
03	3008469	11	管塞	PLUG.PIPES	1	
03	3010030	8	垫片	GASKET.LUB OIL COOLER COVER	1	
03	3010596	2	带垫螺栓	SCREW.CAPTIVE WASHER CAP	10	
03	3013786		管塞	PLUG.PIPES	1	
03	3022961	4	排放塞	PLUG.DRAIN	1	
03	3300908	61	机油滤接头	ADAPTER.LUB OIL FILTER	1	
03	3300912		管接头	ADAPTER.INSERT	1	
03	3305487	62	密封圈	SEAL.RECTANGULAR RING	1	(或 3308958)
02	MP5460		机油冷却器安装	COOLER.LUB MTG	1	

续表-10

级别	零件号	图上 标号	零件名称		数量	备注
			中文	英文		
03	S106C	39	螺栓	SCREW,HEXAGON HEAD CAP	2	
03	S145	41	螺栓	SCREW,HEXAGON HEAD CAP	1	
03	S604	44	弹簧垫圈	WASHER,LOCK	2	
03	43828B	47	软管卡箍	CLAMP,HOSE	4	
03	203310	49	平垫圈	WASHER,PLAIN	1	
03	210966	28	机油冷却器支架	BRACE,OIL COOLER	1	
03	3000907	45	输水管	TUBE,WATER TRANSFER	1	
03	3008017	43	机油冷却器支架座垫片	GASKET,OIL COOLER SUPPORT	1	
03	3010595	40	带垫螺栓	SCREW,CAPTIVE WASHER CAP	2	
03	3010596	38	带垫螺栓	SCREW,CAPTIVE WASHER CAP	2	
03	3010597	42	带垫螺栓	SCREW,CAPTIVE WASHER CAP	2	
03	3031560	46	软管	HOSE,PLAIN	2	
03	3011233	50	出水接头	CONNECTION,WATER OUTLET	1	
03	3011342	52	带垫螺栓	SCREW,CAPTIVE WASHER CAP	6	
03	70089-1	54	衬垫	GASKET,COVER PLATE	1	
02	3313279	67	机油滤清器	ELEMENT,LUB OIL FIL TER	1	

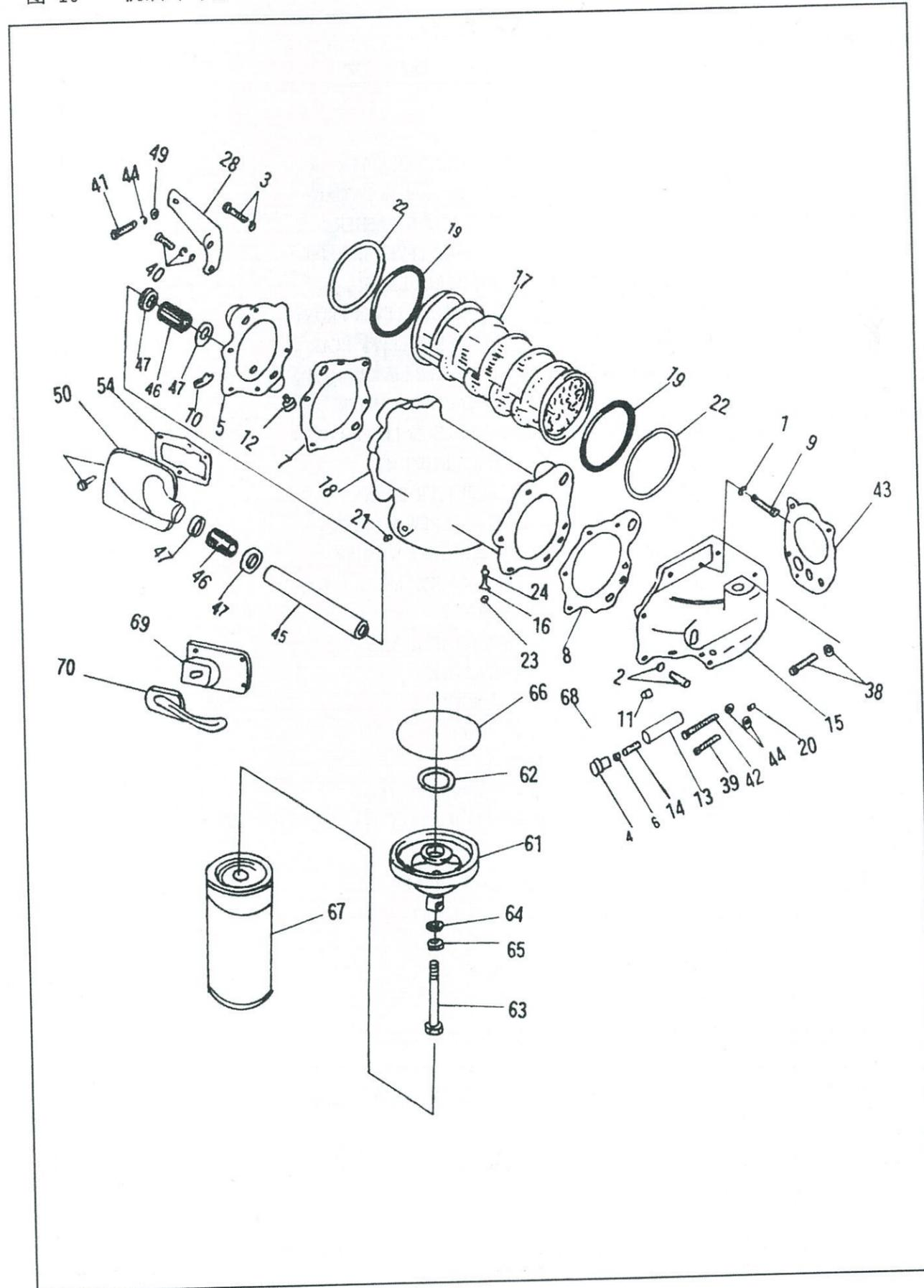
图-11 机油盘



表-11

级别	零件号	图上 标号	零件名称		数量	备注
			中文	英文		
01	OP134		机油盘	PIL PAN	1	
02	3655201		机油盘	PAN,OIL	1	
03	3008470	19	管塞	PLUG PIPE	2	
03	3046869	1	磁性放油塞	MAGNETIC PLUG,OIL DRAIN	3	
03	3046943		密封圈	RING,SEAL	3	
03	3655196	3	机油盘	PAN,OIL	1	
03	3008468	6	管塞	PLUG,PIPE	3	
02	3655202		机油盘安装	PAN,OIL MTG	1	
03	S610	22	弹簧垫圈	WASHER,LOCK	4	
03	S626	21	平垫圈	WASHER,PLAIN	4	
03	S142		六角螺栓	SCREW,HEXAGON HEAD	4	
03	3008069	17	带垫螺栓	SCREW,CAPTIVE WAS	28	
03	103009	2	带垫螺栓	SCREW,CAPTIVE WAS	4	
03	3032861	14	机油盘衬垫	GASKET,OIL PAN	1	
03	MP689		机油尺支架安装	OIL,GUAGE BRACKET MTG	1	
03	67346	5	机油尺支架衬垫	OIL GAUGE BRACKET GASKET	1	
03	3008069	4	带垫螺栓	SCREW,CAPTIVE WAS	2	
02	135814	20	机油尺管支座	BRACKET,DIPSTICK	1	
02	3418990	8	机油尺道管	TUBE,OIL GAUGE	1	
02	3001052	9	机油尺	DIPSTICK	1	

图-12 机油泵

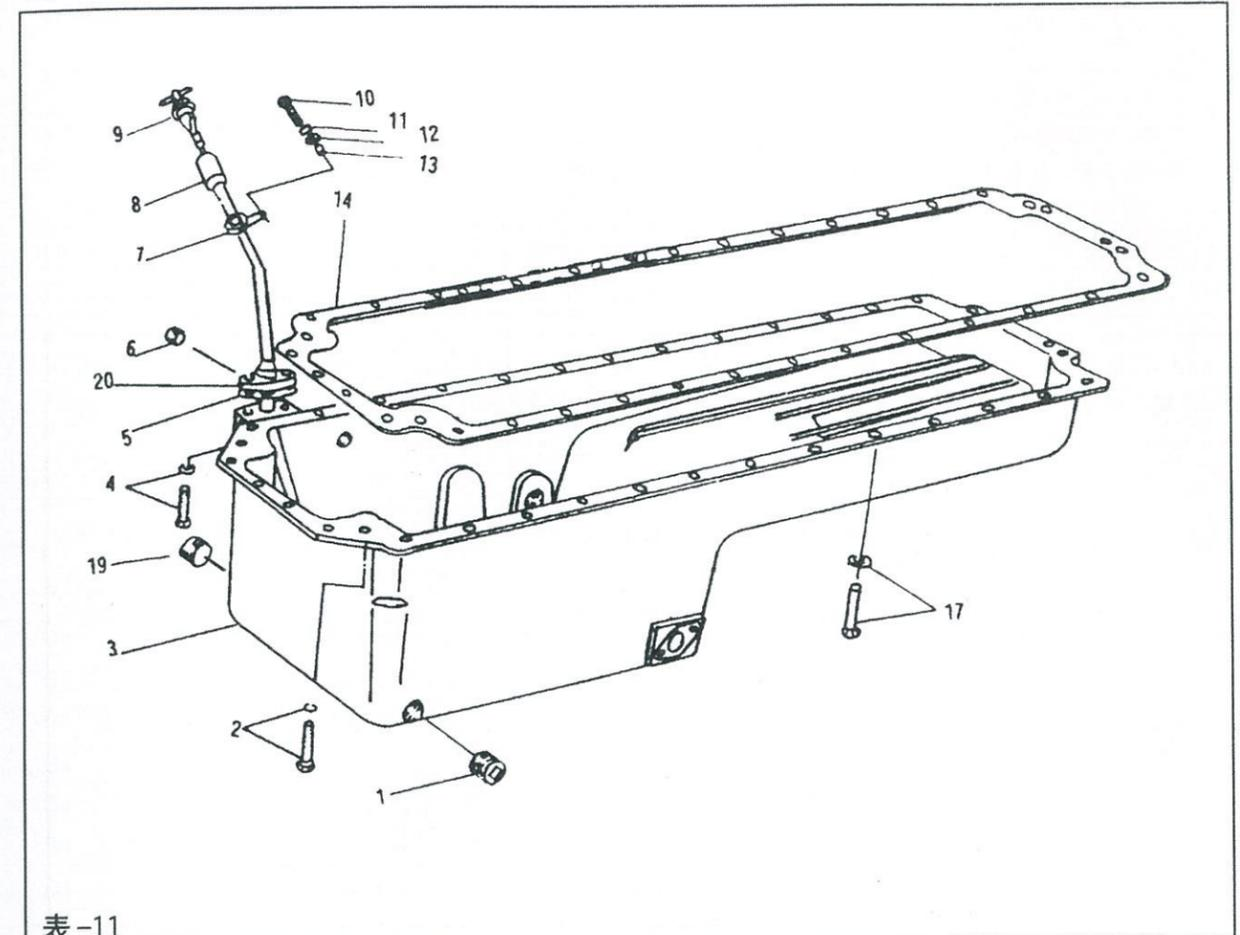

表-12

级别	零件号	图上标号	零件名称		数量	备注
			中文	英文		
02	AR9835		机油泵	PUMP,LUB OIL	1	
03	3012479	29	带垫螺栓	SCREW,CAPTIVE WASHER	2	
03	S-119-C	20	六角螺栓	SCREW,HEXAGON HEAD	1	
03	S-140-C	19	六角螺栓	SCREW,HEXAGON HEAD	1	
03	S-136-B	14	六角螺栓	SCREW,HEXAGON HEAD	1	
03	S-610	13	弹簧垫圈	WASHER,LOCK	3	
03	3067613	2	衬垫	GASKET,LOB POMP	1	
03	3042378		机油泵	PUMP,LUB OIL	1	
04	AR4258		盖子总成	COVER	1	
05	177414	21	盖子	COVER,LUB OIL PUMP	1	
05	69521	3	驱动轴衬套	BUSHING,LUB OIL PUMP DRIVE SH	1	
04	211942		壳体	BODY,LUB OIL PUMP	1	

续表-12

级别	零件号	图上标号	零件名称		数量	备注
			中文	英文		
05	211938	4	壳体和衬套	BODY and BUSHING	1	
06	69521	3	驱动轴衬套	BUSHING,LUB OIL PUMP DRIVE SH	2	
06	211929	4	壳体	BODY,LUBRIC	1	
06	69519	27	定位销	DOWEL PIN	1	
05	177417	26	驱动轴	SHAFT,PUMP DRIVE	1	
05	177419	28	后驱动轴	SHAFT,LUB PUMP	1	
05	3014783	25	齿轮	GEAR,LUB PUMP DRIVE	1	
05	3025281	1	机油泵后转动齿轮	GEAR,LUB PUMP REAR	1	
04	S-103	17	六角螺栓	SCREW,HEXAGON HEAD	1	
04	S-109	33	六角螺栓	SCREW,HEXAGON HEAD	1	
04	S)111	18	六角螺栓	SCREW,HEXAGON HEAD	1	
04	S-605	16	弹簧垫圈	WASHER,LOCK	2	
04	109319	34	锁紧片	LOCKPLATE	1	
04	109333	30	调压阀柱塞	PLUNGER,LUB OIL PRESSURER	1	
04	126304	35	固定夹	CLAMP,RETINING	1	
04	134596		旁通阀塞	PLUG,BY-PASS VALVE LUB	1	
04	203145	22	衬垫	GASKET,LUB OIL PUMP COVER	1	
04	211939		弹簧	SPRING,COMPRESSION	1	
04	3008469		管塞	PLUG,PIPE	2	
04	3014965		齿轮和衬套	GEAR and BUSHING	1	
05	68365	23	衬套	BUSHING	2	
05	3014784	24	齿轮	GEAR,LUB OIL PUMPING	1	
04	3022590	15	带垫螺栓	SCREW,CAPTIVE WASHER	6	
02	3260630		吸油管总成	TUBE,LUB OIL SUCTION	1	
03	197230	7	密封圈	SEAL GROMMET	2	
03	3250943	8	吸油管	TUB,LUB OIL SUCTION	1	
03	217257	5	阳性接头	CONNECTOR,MALE	1	
03	3008795	6	螺母	NUT TUBE	2	
02	3020428		吸油接头	CONNECTION,OIL SUCTION	1	
03	S602	9	平垫圈	WASHER,PLAIN	2	
03	157551	11	衬垫	CASKET,OIL SUC CONNECTION	1	
03	3010595	12	带垫螺栓	SCREW,CAPTIVE WASHER	1	
03	3251022	10	吸油接头	CONNECTION OIL SUCTION	1	

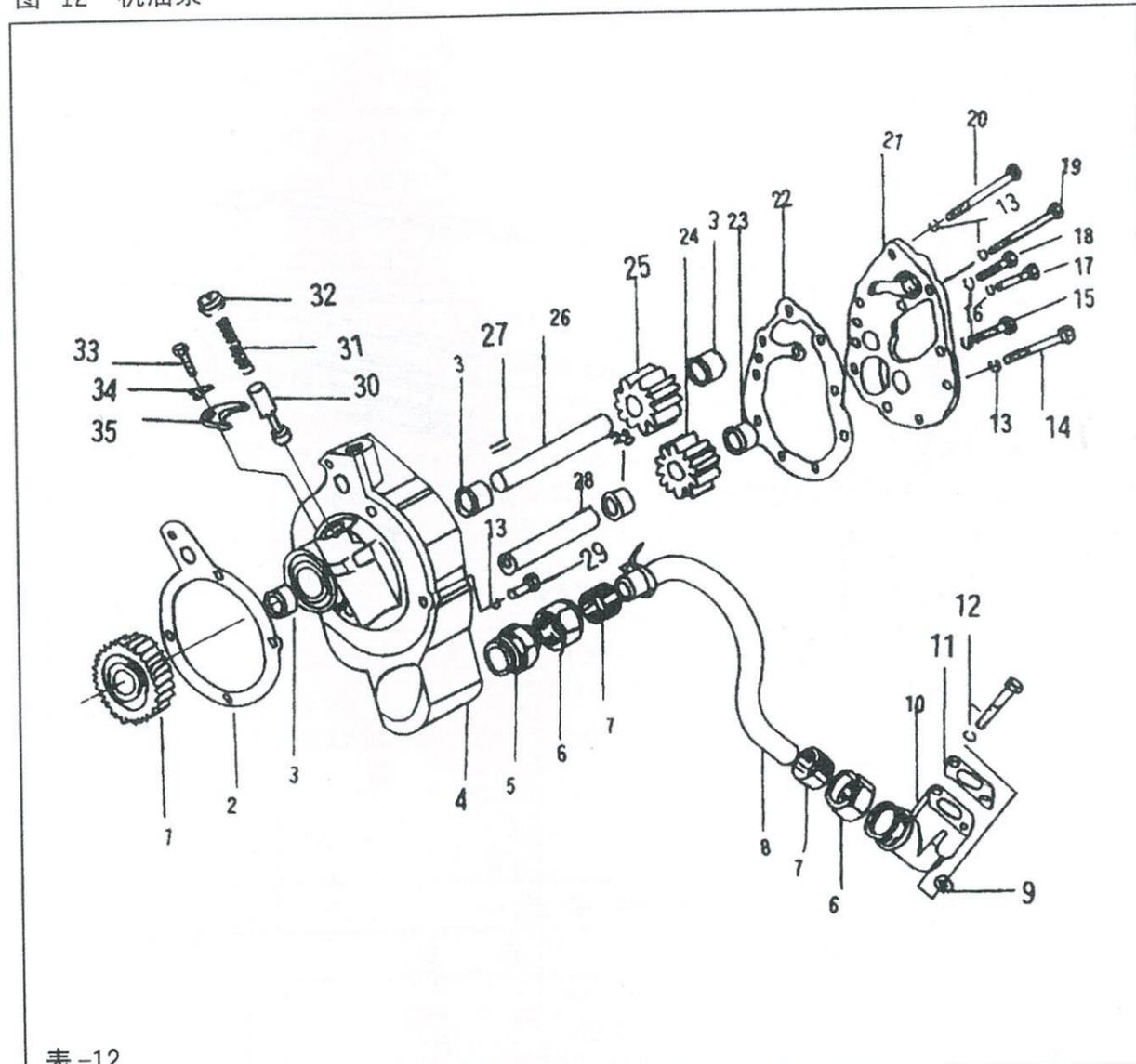
图-13 风扇、轮壳及皮带



表-13

级别	零件号	图上标号	零件名称		数量	备注
			中文	英文		
02	AR11679		风扇支架及安装	SUPPORT,FAN BRACKET	1	
03	S172-A	19	六角螺栓	SCREW,HEXAGON HEAD	3	
03	S176	23	六角螺栓	SCREW,HEXAGON HEAD	2	
03	S285	16	螺母	NUT,HEXAGON HEAD	1	
03	S608	14	弹簧垫圈	WASHER,LOCK	3	
03	117267	15	垫圈	WASHER,COUNTER	2	
03	166777	18	六角螺栓	SCREW,HEXAGON HEAD	1	
03	208829	38	风扇支架	BRACKET,FAN	1	
03	217034	39	风扇支架	BRACKET,FAN	1	
03	3015282	24	带垫螺钉	SCREW,CAPTIVE WAS	2	
03	3019574	37	带垫螺钉	SCREW,CAPTIVE WAS	2	
02	3012649		风扇轮壳总成	HUB,FAN	1	
03	S117		六角螺钉	SCREW,KHEXAGON HEAD	2	
03	S911-B	10	管塞	PLUG,PIPE	2	
03	142176	7	锁紧螺母	NUT,LOCK	1	
03	200307	11	油封	SEAL,OIL	1	

续表-13

级别	零件号	图上标号	零件名称		数量	备注
			中文	英文		
03	211857	20	风扇主轴	SPINDLE,FAN	1	
03	211869	12	风扇皮带轮	PULLEY,FAN	1	
03	3005369		风扇轮壳轴承	BEARING,FAN HUB	1	
04	217008		轴承隔套	SPACER,BEARING	1	
04	217011		轴承隔套	SPACER,BEARING	1	
04	3001280	6	卡环	RING,RETANING	1	
04	3001281	9	轴承	BEARING,ROLLER	2	
03	3008883		防护盖	COVER,PROTECTIVE	1	
03	3012467	8	平垫圈	WASHER,PLAIN	1	
02	178708	17	风扇皮带	BELT,V	2	
02	3419054		风扇及安装	MTG,FAN	1	
03	3005589	4	风扇导向隔套	SPACER,FAN PILOT	1	
03	3005592	5	衬套	GASKET,FAN SPACER	1	
03	100462		风扇隔套	SPACER,FAN	1	
03	3418764	3	风扇	FAN,ENGINE	1	
03	S199-A	1	六角螺栓	SCREW,HEXAGON HEAD	6	
03	S604	2	弹簧垫圈	WASHER,LOCK	6	
03	3012602		附件驱动皮带轮安装	PULLEY,ACCESSORY MTG	1	
03	193136	32	平垫圈	WASHER,PLAIN	1	
03	3008947		键槽密封件	SEAL,DEYWAY	1	
03	3012526	31	螺母	NUT	1	
03	3013786		管塞	PLUG,PIPE	1	
03	3034438		定位销	DOWEL,PIN	1	
03	3016013		附件驱动皮带轮	PULLEY,ACCESSORY DRIVE	1	
03	190397	35	耐磨套	SLEEVE,WEAR	1	
03	215997	33	附件驱动皮带轮	PULLEY,ACCESSORY DRIVE	1	
02	217638	34	水泵皮带	BELT,V RIBBED	1	

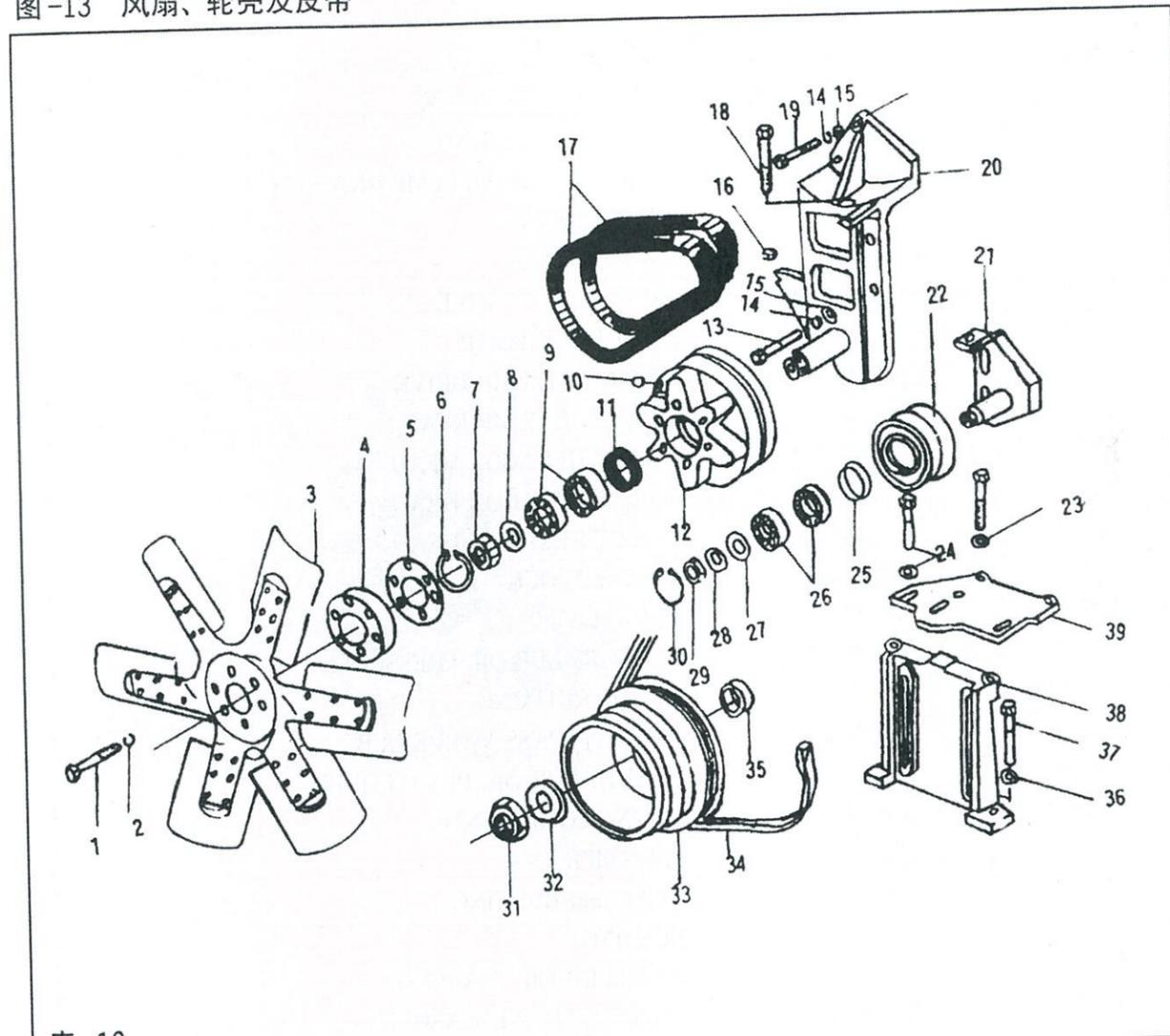
图-14 水泵及惰轮



表-14

级别	零件号	图上 标号	零件名称		数量	备注
			中文	英文		
03	3022474		水泵总成	PUMP,WATER	1	
04	S965E	1	管塞	PULG,PIPE	1	
04	215397	2	中间皮带张紧轮	PULLEY,IDLER	1	
04	208119	3	张紧轮轴	SHAFT,IDLER	1	
04	3010150	4	滚珠轴承	BEARING,IDLER BALL	1	
04	145506	5	O型密封圈	SEAL O RING	1	
04	208120	6	固定隔套	SPACER,MOUNTING	1	
04	S6255	7	档圈	RING,RETAINING	2	
04	3038998	8	油封	SEAL,OIL	2	
03	3012468	9	带垫螺栓	SCREW,CAPTIVE WAS	4	
04	213082	11	平垫圈	WASHER,PLAIN	1	
04	S201	12	六角螺母	NUT,HEAVY HESGON	1	
04	3025935	13	水泵皮带轮	PULLEY,WATER PUMP	1	
05	203097	14	耐磨套	SLEEVE,WEAR	1	
04	3010150	15	滚珠轴承	BEARING,IDLER BALL	2	
04	196844	16	隔套	SPACER BEARING	1	
04	112302	17	卡环	RING,BETAINING	1	
04	3000889	18	水泵轴	SHAFT,WATER PUMP	1	
04	3038997	19	油封	SEAL,OIL	1	
03	3012469	20	带垫螺栓	SCREW,CAPTIVE WAS	2	
04	3013786	21	管塞	PLUG,PIPE	1	
03	3012470	22	带垫螺栓	SCREW,CAPTIVE WAS	1	
03	3010595	24	带垫螺栓	SCREW,CAPTIVE WAS	4	
03	3419021	26	进水接头	CONNECTION,WATER	1	
03	3024960	27	衬垫	GASKET,CONNECTION	1	
04	218274	28	水泵壳体	BODY,WATER PUMP	1	
03	214617	29	管夹	CLAMP,HOSE	1	
03	3022589	31	带垫螺栓	SCREW,CAPTIVE WAS	1	
04	S911B	32	管塞	PLUG,PIPE	2	
03	3002385	33	安装垫片	GASKER,WATER PUMP	1	
03	182706	34	调节螺栓	SCREW,HEXAGON HEAD	1	
04	3033677	35	水封和水封座总成	ASSEMBLY SEAL&SEAT	1	
04	3000888	36	水泵叶轮	IMPELLER,WATER PUMP	1	

图-15 节温器及水管

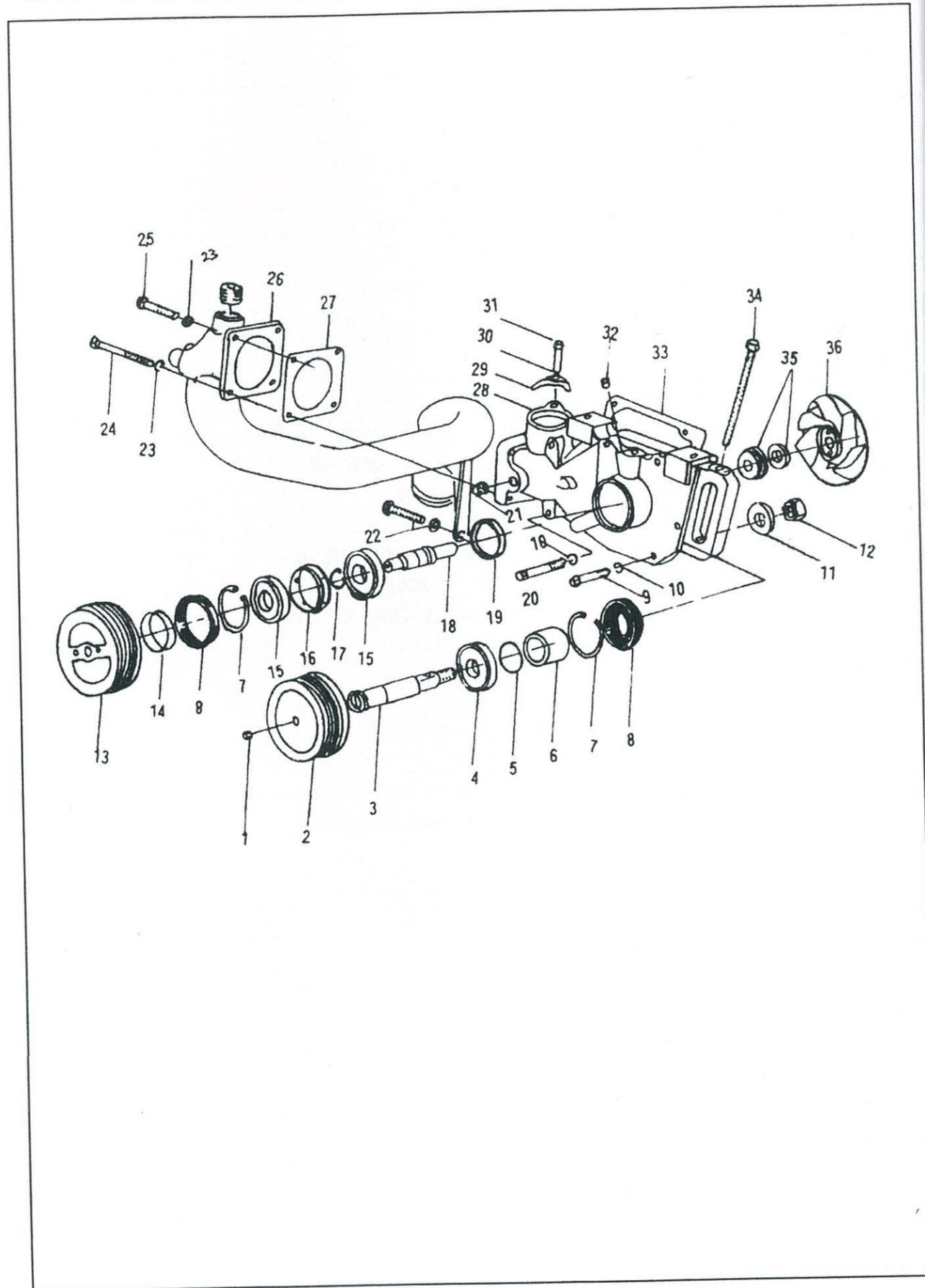

表-15

级别	零件号	图上 标号	零件名称		数量	备注
			中文	英文		
02	AR10124		节温器壳	HOUSING,THERMOST	1	
03	186780	7	节温器密封	SAEL,THERMOST	1	
03	3013612	3	节温器壳	HOUSING,THERMOSTA	1	
02	MP4533		水管接头安装	CONNECTION,WATER	1	
03	3010595	6	带垫螺栓	SCREW,CAPTIVE WAS	2	
03	3018764	5	出水管接头	CONNECTION,RADIATOR	1	
03	3019158	4	垫片	GASKET	1	
02	201737	10	节温器	THERMOSTAT	1	
02	3010870		节温器壳安装	MTG,THERMOSTAT HOUSING	1	
03	208128	11	节温器壳垫片	GASKET,HOUSING	1	
03	3010597	8	带垫螺栓	SCREW,CAPTIVE WAS	4	

续表-15

级别	零件号	图上 标号	零件名称		数量	备注
			中文	英文		
03	3013786		管塞	PLUG, PIPE	1	
02	AR9480		输水管	TUBE,WATER TRANSFER	1	
03	S626		平垫圈	WASHER,PLAIN	1	
03	212161	25	O型密封圈	SEAL,O RING	2	
03	3024666	26	输水管	TUBE,WATER TRANSFER	1	
02	AR10032		傍通水管	TUBE,WATER BYPASS	1	
03	43463A	23	O型密封圈	SEAL,O RING	1	
03	43828B	20	夹箍	CLAMP,HOSE	2	
03	213485	22	傍通水管	TUBE,WATER BYPASS	1	
03	214617	24	管夹	CLAMP,TUBE	1	
03	3022589		带垫螺栓	SCREW,CAPTIVE WAS	1	
03	102522	21	软管	HOSE	1	
02	MP5144		中水管安装	MTG,MANIFOLD WATER	1	
03	70624	13	O型密封圈	SEAL,O RING	2	
03	130394	14	水管接头	CONNECTION,WATER	1	
03	3010596	16	带垫螺栓	SCREW,CAPTIVE WAS	4	
03	3024709	19	矩形密封圈	SEAL,RECTANGULAR	2	
02	130118	15	中水管	MANIFOLD WATER	1	
02	3013001	18	后水管	MANIFOLD WATER	1	
02	3014957		前水管安装	MTG,MANIFOLD WATER	1	
03	3008468		管塞	PLUG PIPE	2	
03	3008469		管塞	PLUG PIPE	1	
03	3010596		带垫螺栓	SCREW CAPTIVE WAS	4	
03	3013786	16	管塞	PLUG PIPE	1	
03	3024709		矩形密封圈	SEAL,RECTANGULAR	2	
03	3025458	19	管塞	PLUG PIPE	1	
02	3015115	12	前出水管	MANIFOLD WATER	1	
02	3038047		出水管安装	MTG,MANIFOLD WATER	1	
03	3008468		管塞	PLUG, PIPE	1	
02	MP5146		后水管安装	MTG,MANIFOLD WATER	1	
03	70624	13	O型密封圈	SEALO RING	2	
03	130394	14	水管接头	CONNECTION WATER	1	
03	3008468		管塞	PLUG, PIPE	1	
03	3010596	16	带垫螺栓	SCREW CAPTIVE WAS	4	
03	3024709	19	矩形密封圈	SEAL RECTANGULAR	2	

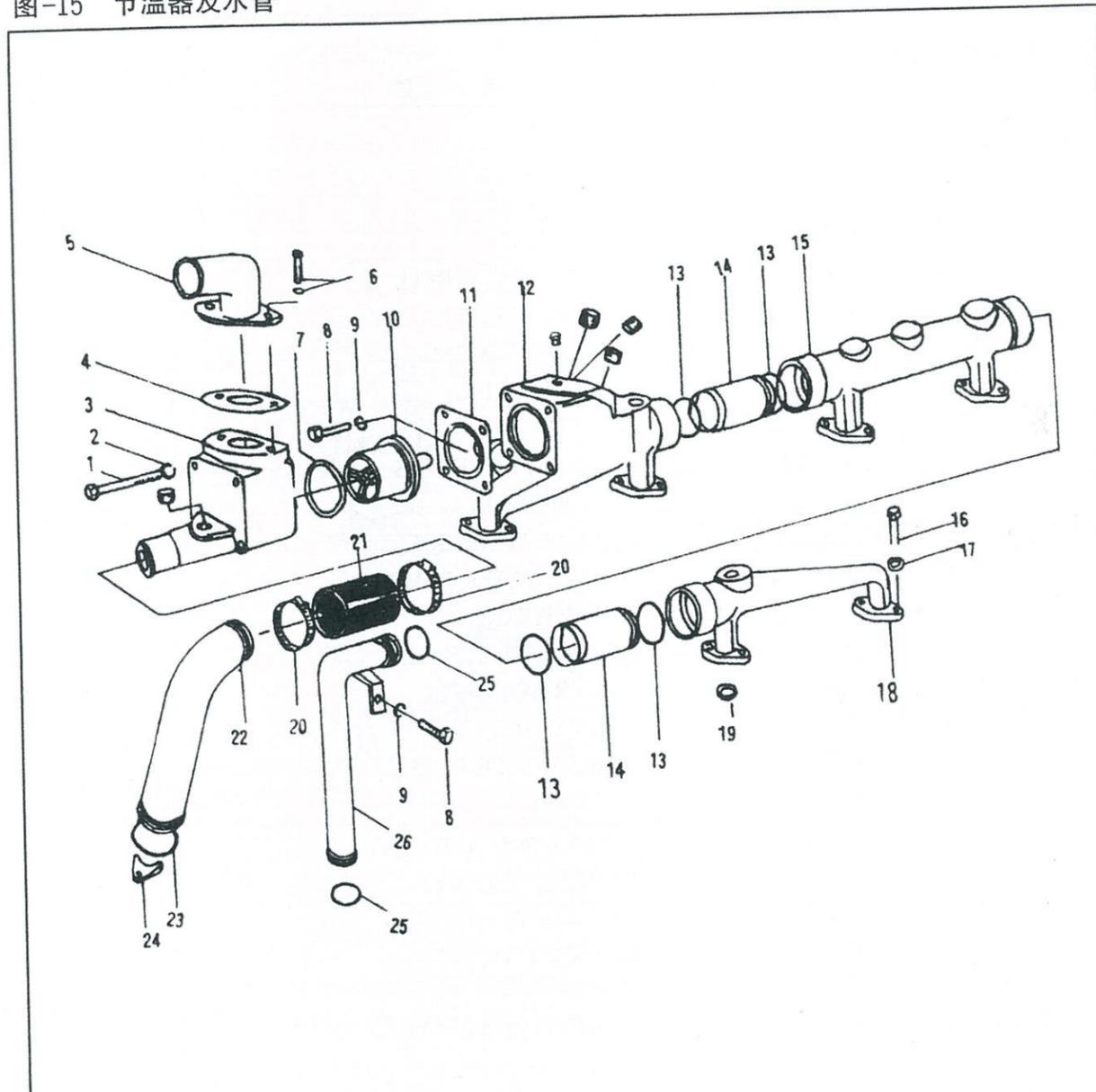
图-16 中冷器和进气管



表-16

级别	零件号	图上 标号	零件名称		数量	备注
			中文	英文		
02	3419234		中冷器总成	INTERCOOLER,AIR	1	适用于G1机型
04	S102	1	六角螺栓	SCREW HEXAGON HEAD	3	
04	3012471	2	带垫螺栓	SCREW,CAPTIVE WAS	2	
04	3005508	3	六角螺栓	SCREW HEXAGON	24	
04	3028282	4	进水接头	CONNECTION,WATER	1	
04	3013295	5	出水接头	CONNECTION,WATER OUTLET	1	
04	214154	6	中冷器盖	COVER AFTERCOOLER	1	
04	3028997	7	中冷器芯	CORE,AFTERCOOLER	1	
04	3032348	9	进水接头衬垫	GASKET,WTR CONNECTION	1	
04	215044	10	出水接头衬垫	GASKET,WTR CONNECTION	1	
04	216486	11	中冷器盖衬垫	GASKET,AFT HOUSING	1	
04	3008425	12	中冷器壳体	MANIFOLD,AIR INTAKE	1	
04	195952	13	O型密封圈	SEAL,O RING	4	
03	70295	15	管塞	PLUG,PIPE	1	
04	3030286	20	带垫螺栓	SCREW,CAPTIVE WAS	8	
03	S684	19	平垫圈	WASHER PLAIN	3	
03	S103D	21	六角螺栓	SCREW,HEXAGON HEAD	4	
02	211657	22	空气跨越管	CONNECTION,AIR CROSSOVER	1	
03	208326	23	T型卡箍	CLAMP,TEE BOLT	2	
03	216487	24	连接管衬垫	GASKET,CONNECTION	1	
03	202994	25	软管	HOSE,PLAIN	1	
03	70295	27	管螺塞	PLUG,PIPE	1	
03	S679	28	平垫圈	WASHER,PLAIN	4	
03	43828A	29	软管卡箍	CLAMP,HOSE	4	
03	215041	30	输水管	TUBE,WATER TRANSFER	1	
03	3056138	30	软管	HOSE,PLAIN	2	
03	S190	33	六角螺栓	SCREW,HEXAGON HEAD	1	
03	43828A	36	软管卡箍	CLAMP,HOSE	4	
03	204263	37	夹子	CLIP	1	
03	3818267	40	软管	HOSE,PLAIN	2	
03	S603	43	弹簧垫圈	WASHER,LOCK	1	
03	S658	43	平垫圈	WASHER,PLAIN	1	
03	3001169	45	输水管	TUBE,WASHER TRANSFER	1	
03	3011716	46	带垫螺栓	SCREW,CAPTIVE WAS	2	
03	3028967	47	带垫螺栓	SCREW,CAPTIVE WAS	6	
03	S604	48	弹簧垫圈	WASHER,LOCK	1	
03	63842	49	平垫圈	WASHER,PLAIN	1	
03	69047A	50	内六角螺栓	SCREW,SOCKET HEAD	1	
03	70295	51	管塞	PLUG,PIPE	1	
03	3008591	52	进气歧管衬垫	GASKET,INTAKE MANIFOLD	3	

图-17 进气管

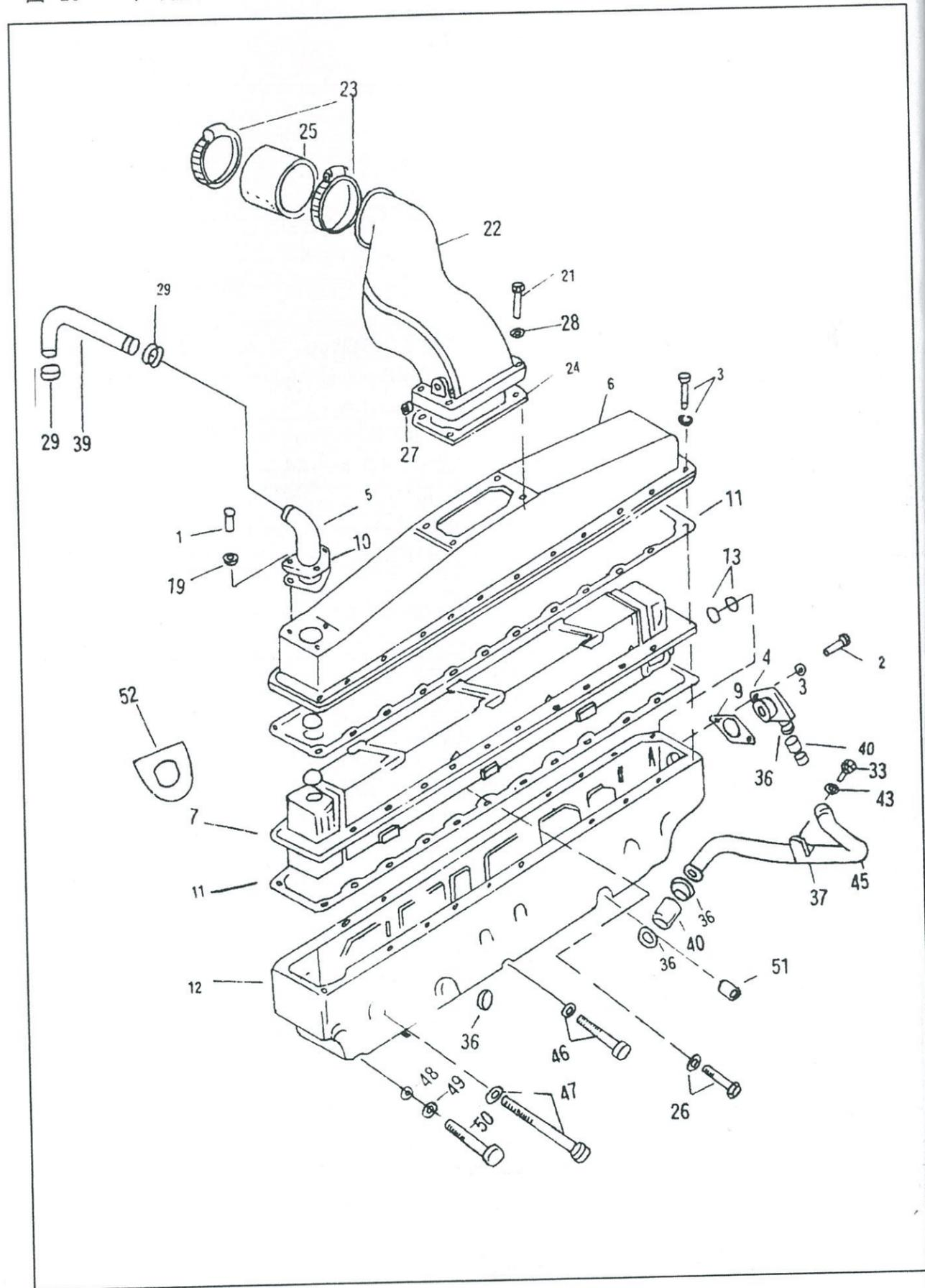

表-17

级别	零件号	图上标号	零件名称		数量	备注
			中文	英文		
02	3031588		进气管安装	MTG.AIR INTAKE	1	
03	S604	14	弹簧垫圈	WASHER,LOCK	1	
03	63842	15	平垫圈	WASHER,PLAIN	1	
03	69047A	13	内六角螺钉	SCREW,SOCKET HEAD CAP	1	
03	70295	11	管塞	PLUG,PIPE	1	
03	144257	2	盖板	PLTAE,COVER	1	
03	3008466	12	管塞	PLUG,PIPE	3	
03	3008477		管塞	PLUG,PIPE	1	
03	3008591	18	进气管衬垫	GASKET,INTAKE MANIFOLD	3	
03	3010595	16	带垫螺栓	SCREW,CAPTIVE WASHER	6	
03	3011715	3	带垫螺栓	SCREW,CAPTIVE WASHER	6	
03	3011716	10	带垫螺栓	SCREW,CAPTIVE WASHER	2	
03	3019227	1	进气管衬垫	GASKET,INTAKE MANIFOLD	1	
02	141761	17	进气管	MANIFOLD,AIR INTAKE	1	
02	3026529		空气跨越管接头	CONNECTION,AIR CROSSVER	1	
03	70295	9	管塞	PLUG,PIPE	1	
03	3012428	6	空气跨越管接头	CONNECTION,AIR CROSSVER	1	
02	3028629		空气跨越管安装	MTG,AIRCROSSVER CONN	1	
03	208326	4	T型螺栓夹箍	CLAMP,T BOLT	2	
03	3011715	7	带垫螺栓	SCREW,CAPTIVE WASHER	6	
03	3019227	8	进气管衬垫	GASKET,INTAKE MANIFOLD	1	
03	3060613	5	软管	HOSE,PLAIN	1	

图-18 排气管

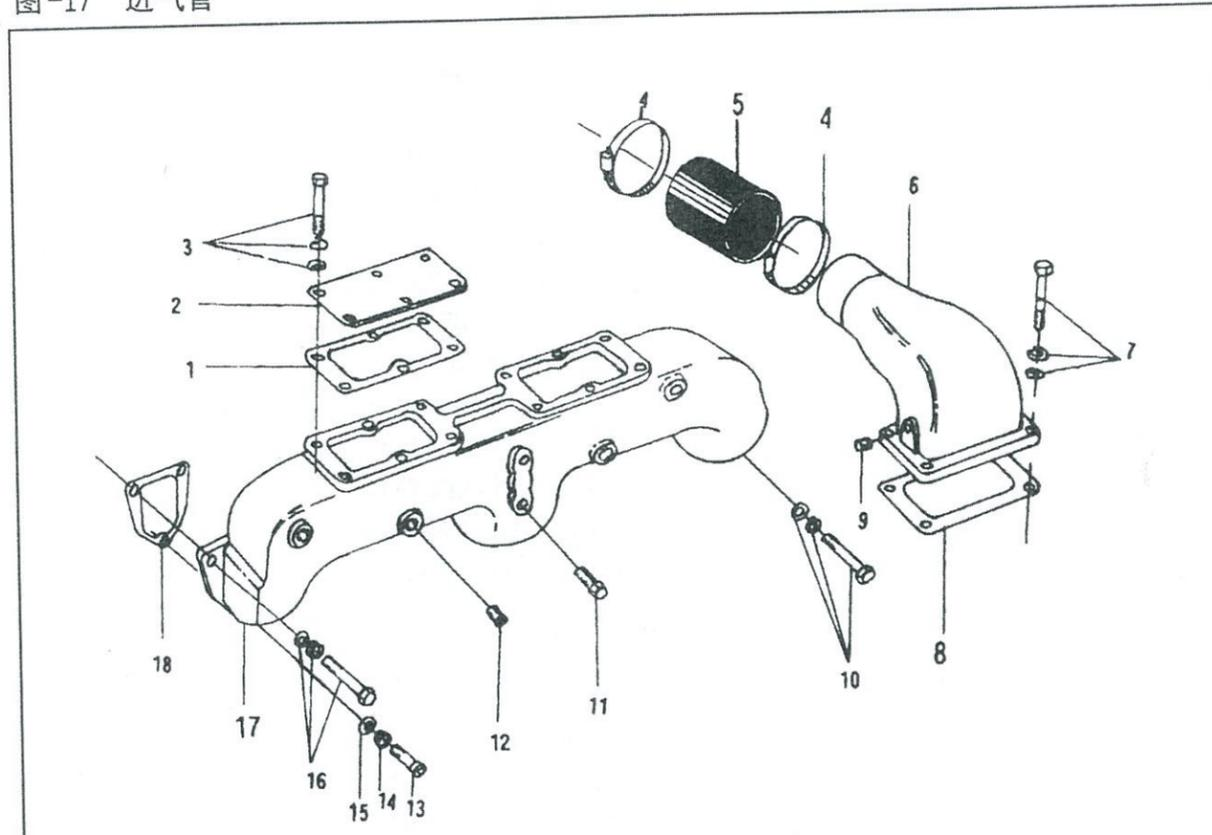

表-18

级别	零件号	图上标号	零件名称		数量	备注
			中文	英文		
02	MP3952		排气管安装	MANIFOLD,EXHAUST MTG	1	
03	S155	2	六角螺栓	SCREW,HEXAGON HEAD	8	
03	105199	11	定位销	DOWEL	6	
03	109594	3	平垫圈	WASHER,PLAIN	8	
03	110266	6	六角螺栓	SCREW,HEXAGON HEAD	2	
03	114638	7	销紧片	PLAIN,LOCK	2	
03	116982	5	锁紧片	PLAIN,LOCK	4	
03	142234	10	排气管衬垫	GASKET,EXHUST MANIFOLD	6	
03	200919	8	压板	CLAMP,EXHAUST MANIFOLD	2	
02	151478	1	排气管(前)	EXHAUST MANIFOLD	1	
02	200566	4	排气管(中)	EXHAUST MANIFOLD	1	
02	151489	9	排气管(后)	EXHAUST MANIFOLD	1	

图-19 涡轮增压器

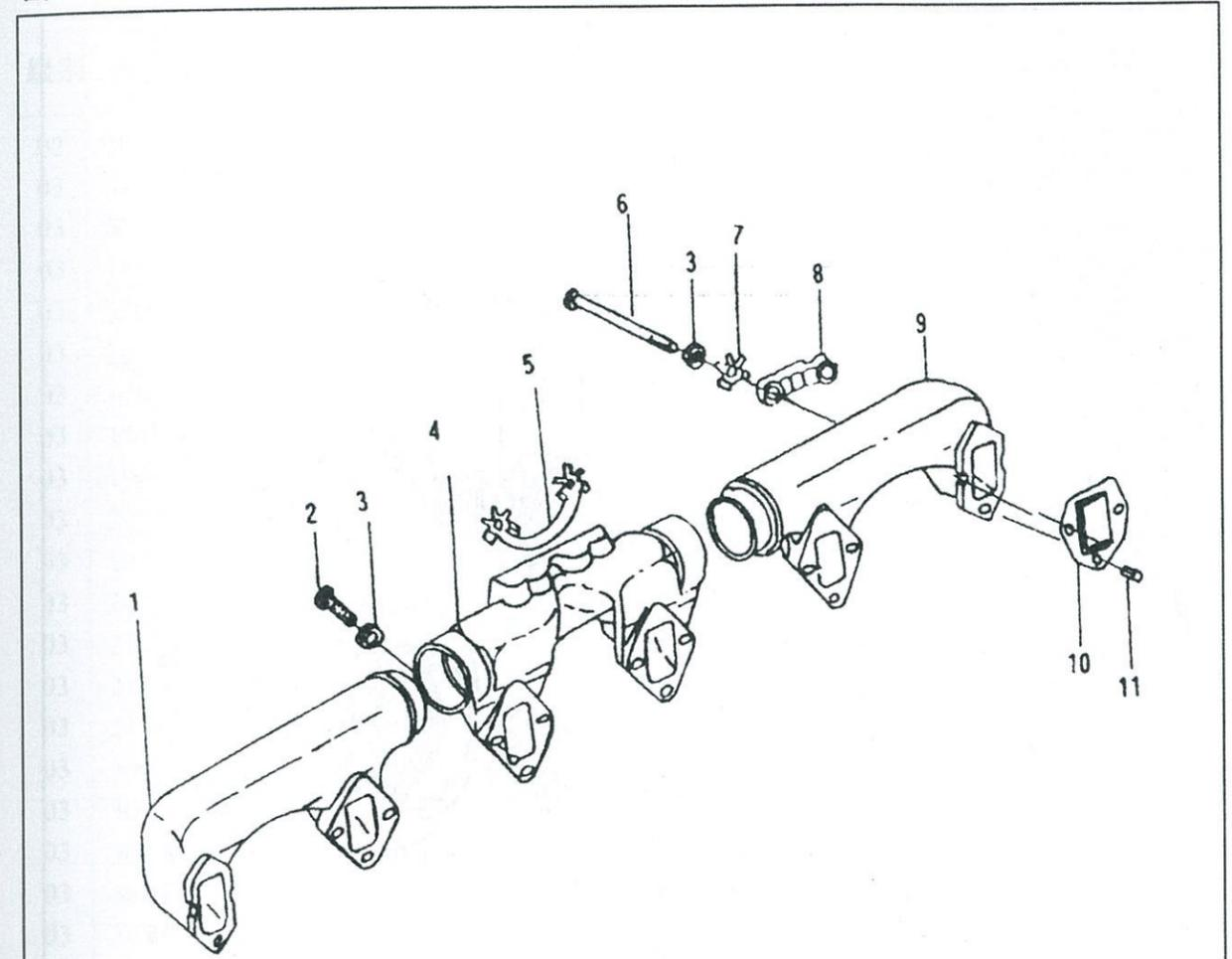

表-19

级别	零件号	图上 标号	零件名称		数量	备注
			中文	英文		
02	3032060		增压器	TURBOCHARGER	1	
03	S-631	4	平垫圈	WASHER,PLAIN	4	
03	S2286		自攻螺钉	SCREW,DRIVE	4	
03	156420	12	增压器轴承	BEARING,TURBOCHARGER	1	
03	156444	7	压气机端密封环	SEAL,SPLIT RING	1	
03	167299	22	锁紧螺母	NUT,LOCK	2	
03	170510	11	轴承镶座	BEARING,INSERT	1	
03	171570	20	隔热板	SHIELD,HEAT	1	
03	194010	3	六角螺栓	SCREW,HEXGON HEAD	2	
03	202377	21	隔热板	PAD,TUR INSUL TION	1	
03	202456	10	O型密封圈	SEAL,O RING	1	
03	202503	17	涡轮壳体	HOUSING,TURBING	1	
03	214086	18	涡轮和轴	WHEEL and SHAFT	1	
03	216802	8	油封环支承套	SLEEVE,TURBOCHARGER	1	
03	216804	9	密封圈支架	SUPPORT,TURBOCHARGER SEAL	1	
03	3002731	6	压气机叶轮	IMPPOLER,TUR COMPRESSOR	1	
03	3011088		名牌	DATE-PLATE	1	
03	3027305	1	压气机壳	HOUSING,COMPRESSOR	1	
03	3034304	5	锁紧螺母	NUT,LOCK	1	
03	3034720	2	V型板夹	CLAMP,V BAND	2	
03	3034736	19	油环	SEAL,SPLIT RINGRING	2	
03	3038745	13	轴承壳	HOUSING,TUB BEARING	1	
02	3030499		增压器安装	TURBOCHARGER,MTG	1	
03	190849	16	衬垫	GASKET,EXH COLLECTOR	1	
03	219138	14	六角螺母	NUT,REGULARHEXAGON	4	
03	3042353	15	双头螺栓	STUD	4	
02	AR8635		排气接头	CONNECTION,EXHAUST OUTLET	1	
03	186917		V型卡箍	CLAMP,V BAND	1	
03	203432		排气接头	CONNECTION,EXHAUST OUTLET	1	

图-20 增压器进回油管

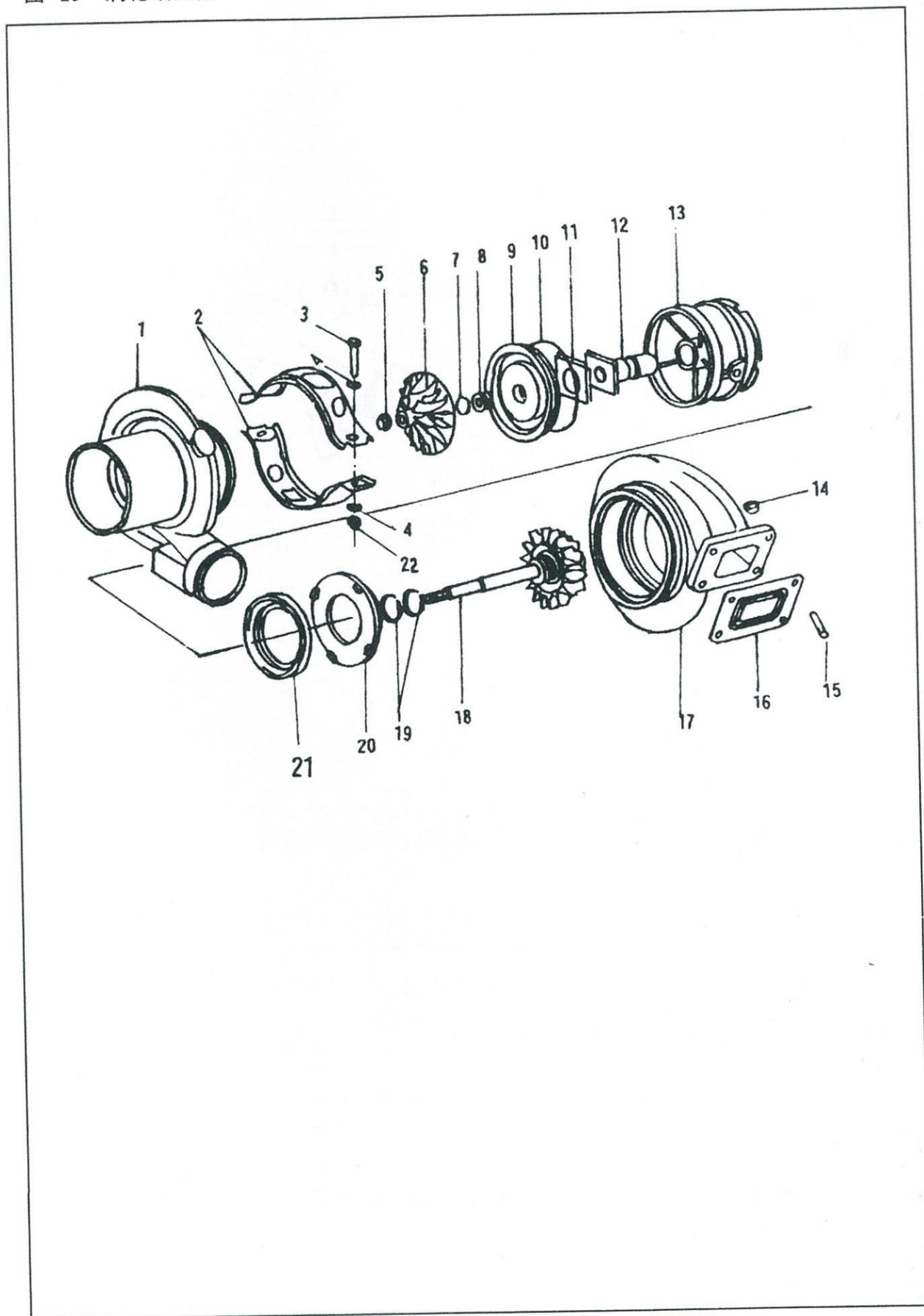

表-20

级别	零件号	图上标号	零件名称		数量	备注
			中文	英文		
03	3037019		增压器管路	TURBOCHARGER, PLUMBING	1	
03	S-107	1	六角螺栓	SCREW, HEXAGON HEAD	3	
03	S-221		六角螺栓	NUT, HEAVY HEXAGON	2	
03	S-605	1	弹簧垫圈	WASHER, LOCK	3	
03	S-626	1	平垫圈	WASHER, PLAIN	3	
03	69465		夹子	CLIP	1	
03	108722	2	夹子	CLIP	2	
03	142429	8	阳性弯管接头	ELBOW, MALE ADAPTER	1	
03	209959	3	进油软管	HOSE, FLEXIBLE	1	
03	43828	9	管夹	CLAMP, HOSE	2	
03	3003536	5	回油管接头	ELBOW, TURBO OIL RETURN	1	
03	3011258	6	密封圈	FLARE, SEAL	1	
03	3014354	4	阳性接头	CONNECTOR, MALE	1	
03	3022865	11	阴性接头	CONNECTOR, FEMALE	1	
03	3022867	7	回油管	TUBE, TUB OIL DRAIN	1	
03	3028616		软管支架	BRACE, HOSE	1	
03	3065060	10	软管	HOSE, FLEXIBLE	1	

图-21 附件驱动

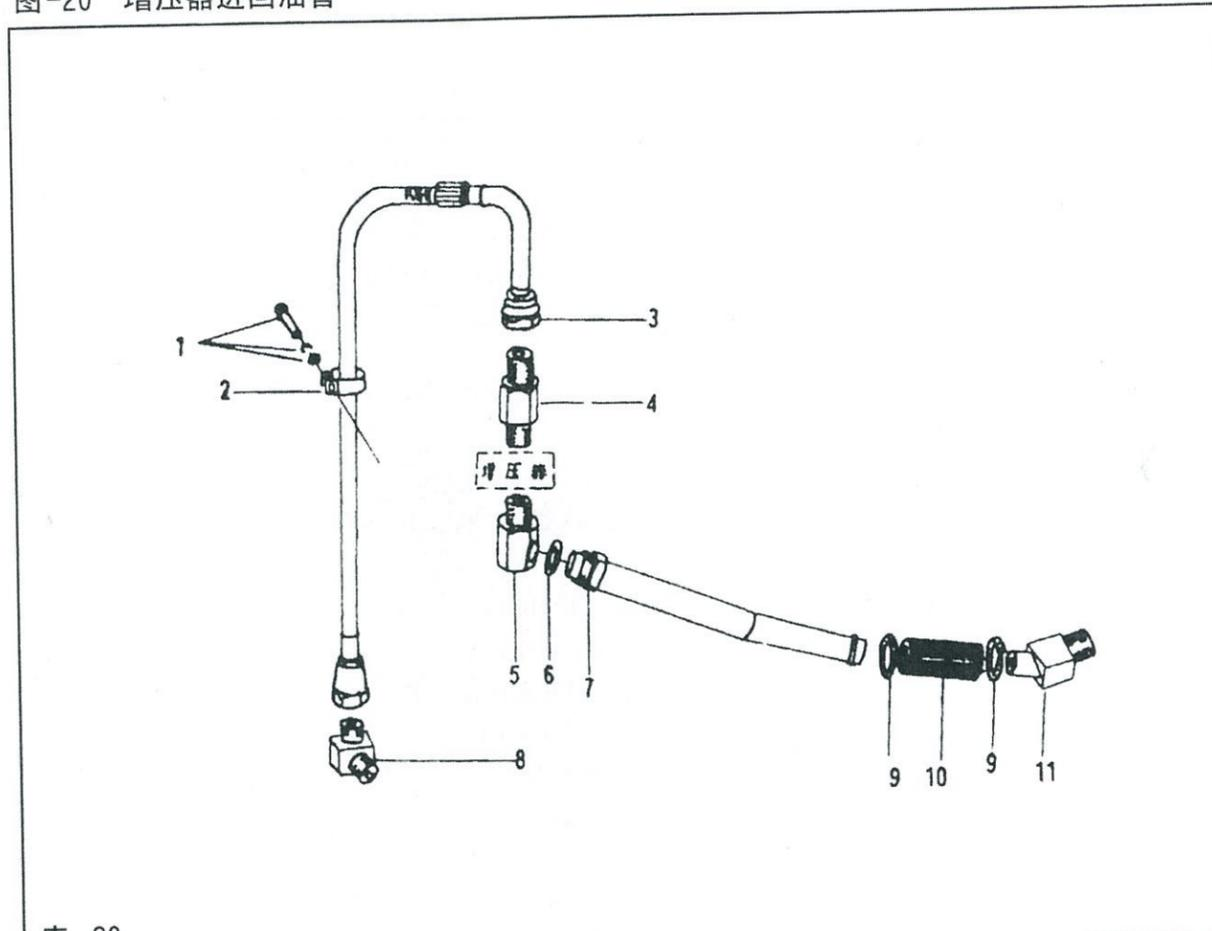

表-21

级别	零件号	图上标号	零件名称		数量	备注
			中文	英文		
03	3005131		辅助驱动	DRIVE, ACCESSORY	1	
03	AR45728	6	辅助驱动壳体	HOUSING, ACCESSORY	1	
04	S911-B	12	管塞	PLUG, PIPE	2	
04	116391	7	衬套	BUSHING	1	
04	3002170	-	附件驱动壳体	SUPPORT, FUEL PUMP	1	
03	129510	11	六角螺栓	SCREW, HEXAGON HEAD	1	
03	142689	2	辅助驱动齿轮	GEAR, ACCESSORY DR	1	
03	170664	10	平垫圈	WASHER, PLAIN	1	
03	3000171	-	辅助驱动轴	SHAFT, ACCESSORY DRIVE	1	
03	3000175	-	转动轴接合爪	COUPLING, F P DRI	1	
03	3014103		平垫圈	WASHER, PLAIN	1	
03	3026556	8	止推轴承	BEARING, THRUST	1	
03	3026557	3	止推轴承	BEARING, THRUST	1	
03	3034438	4	定位销	PIN, GROOVE	1	
02	3007821		辅助驱动安装	MTG, ACCESSORY DRIVE	1	
03	200809	1	辅助驱动室垫片	GASKET, ACC DR HSG	1	
03	3010590	13	带垫螺栓	SCREW, CARTIVE WAS	5	
03	3008947	14	键槽密封	SEAL, KEYWAY	1	

图-22 燃油总成

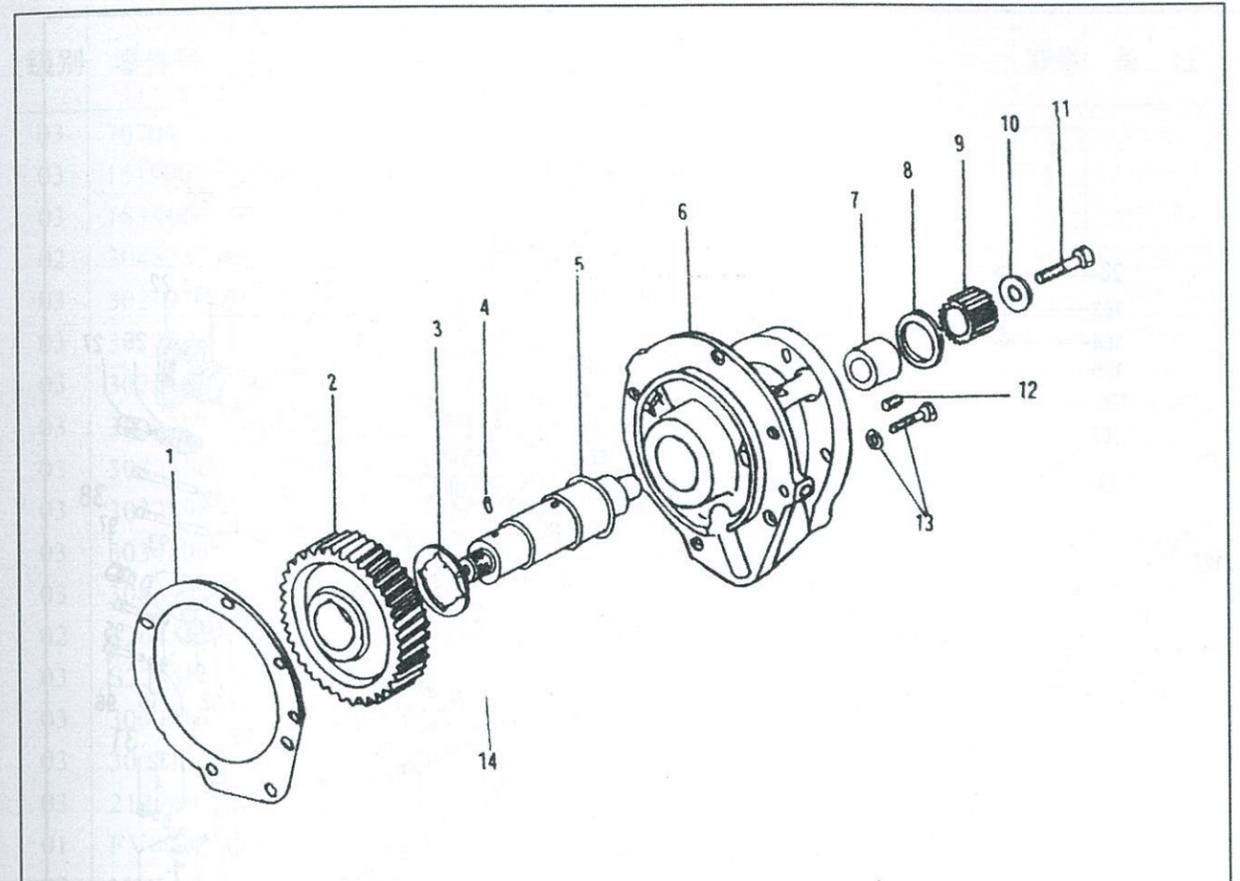

表-22

级别	零件号	图上 标号	零件名称		数量	备注
			中文	英文		
01	FP1687		燃油泵	FUEL PUMP	1	
02	AR12110		燃油泵减振器及安装	DAMPER,FUEL PUMP & MTG	1	
03	BM76340		燃油泵减振器	DAMPER,FUEL PUMP	1	
04	S170C	18	内六角螺栓	SCREW,SOCKET HEAD	2	
04	181466	13	弹簧垫圈	WASHER,LOCK	2	
04	70704	17	平垫圈	WASHER,PLAIN	2	
04	100099	20	矩形密封圈	SEAL,RECTANGULAR RINGR	1	
04	139988	19	矩形密封圈	SEAL,RECTANGULAR	1	
04	153336	21	减振器体	BODY,DAMPER	1	
04	153338	22	减振器盖	PLATE	1	
04	160514	23	尼龙垫圈	WASHER,NYLON	1	
04	202897	24	减振器膜片	DIAPERAGM FP DAMP	1	
03	S174C	16	内六角螺栓	SCREW,SOCKET HEAD	2	

续表-22

级别	零件号	图上 标号	零件名称		数量	备注
			中文	英文		
03	70704	17	平垫圈	WASHER,PLAIN	2	
03	151900	25	矩形密封圈	SEAL,RECT RING	1	
03	181466	13	弹簧垫圈	WASHER,LOCK	2	
02	3048242		燃油泵总成	PUMP,PUEL	1	
03	3021970		燃油泵安装件	HARDWARE,GEAR PUMP	1	
03	3021977		弹簧组罩壳总成	COVER,SPRING	1	
03	3025460		管塞	PLUG,PIPE	1	
03	3030267		燃油泵盖总成	COVER,FUEL PUMP FRONT	1	
03	3032896		电子调速器执行器	GOVERNOR,EFC	1	
03	3032898			HARDWARE,F.P.INTERNAL	1	
03	3034209		齿轮泵总成	PUMP,GEAR FUEL	1	
03	3048241		燃油泵体总成	BODY,FUEL PUMP	1	
02	3261567		燃油泵铅封件	SEAL,FUEL PUMP	1	
03	S2286	138	溃攻螺钉	SCREW,DRIVE	2	
03	3000446	99	油门盖板	COVER,FUEL CONTROL	1	
03	3003156		铅封	SEAL WIRE	1	
03	213769		钢球	PLUG,BALL	1	
01	FV8012		燃油切断阀	FUEL VALVE	1	
02	MP1356		电磁阀安装	VALVE,SOLENDIN MTG	1	
03	S189C	12	内六角螺栓	SCREW,SOCKET HEAD	2	
03	67684	14	平垫圈	WASHER,PLAIN	2	
03	154087	15	矩形密封圈	SEAL,PECTANGULAR RING	1	
03	181466	13	弹簧垫圈	WASHER,LOCK	2	
03	3018453		切断阀	VALVE,SHUTOFF	1	
03	S607	11	弹簧垫圈	WASHER,LOCK	4	
03	129768	1	弹簧片	SPRING,VALVE	1	
03	129839	2	发断阀挡片	SHIELD,SHUTOFF VALVE	1	
03	129886	4	切断阀体	BODY,SHUTOFF VALVE	1	
03	129888	8	矩形密封圈	SEAL,RECTANGVL ARRING	2	
03	196057	10	阀盘	DISC,VALVE	1	
03	196066	9	电磁阀	SOLENOID	1	
03	3018047	11	螺栓	SCREW,FILLISTER HEAD CAP	4	
03	3025458	3	管塞	PLUG,PIPE	1	
03	3034451	4	电磁阀壳	HOUSING,ACTUATOR	1	
03	3034452		圆盘	DISC,ACTUATOR	1	
03	129838	5	捏手		1	
03	190876	6	O型圈		1	
03	3000266	7	停车阀轴		1	

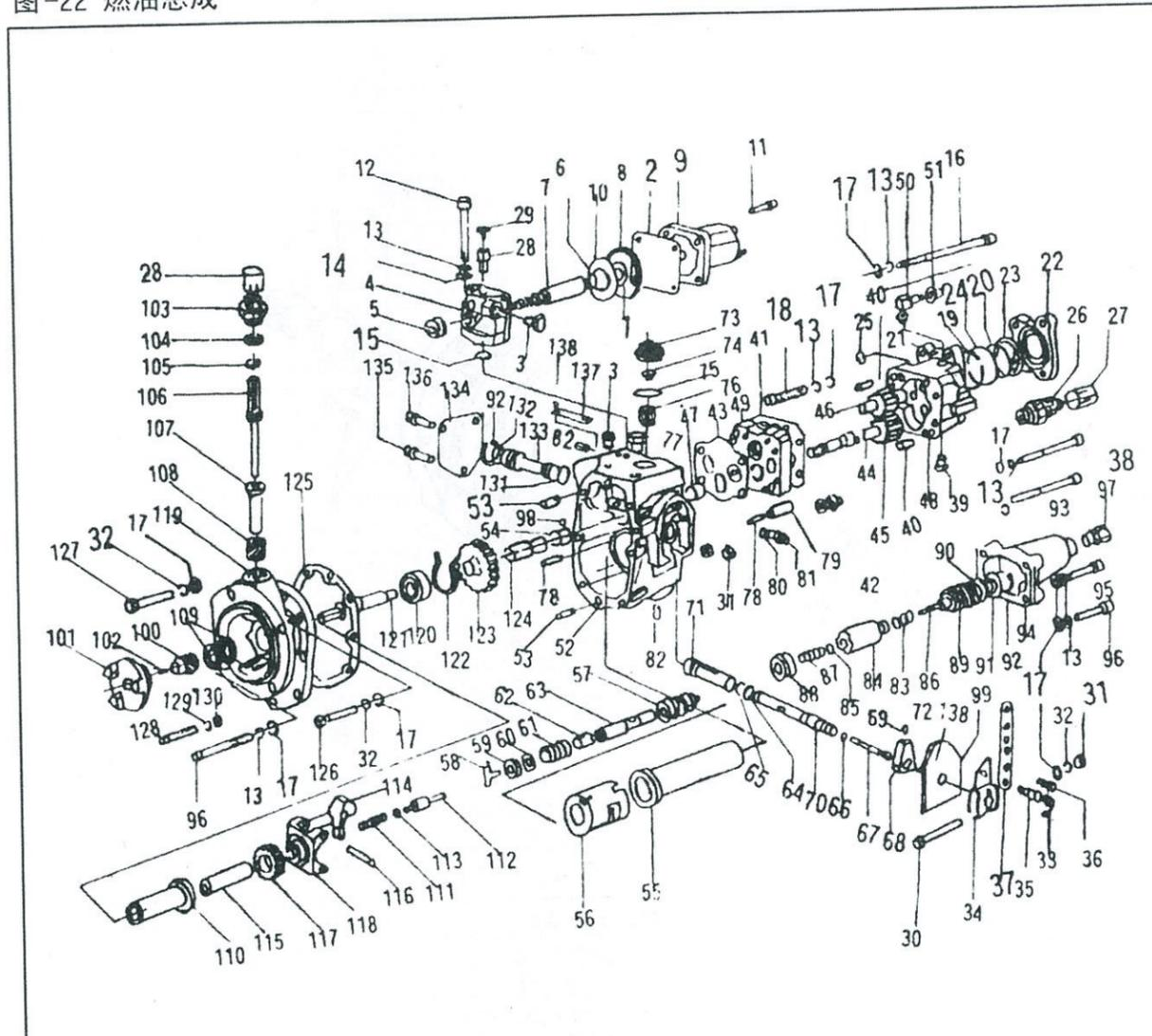
图-23 喷油器



表-23

级别	零件号	图上标号	零件名称		数量	备注
			中文	英文		
02	3054218		喷油器总成	INJECTOR	6	
03	166009	8	压缩弹簧	SPRING.COMPRESSION	6	
03	167157	16	球阀	BALL.CHECK	6	
03	173086		衬垫	GASKET.INJECTOR	6	
03	174299	13	滤网挡环	RETAINRE.SCREEN	6	
03	185138	19	量杯挡环	RETAINER.INJECTOR CUP	6	
03	185139	9	联接器	ADAPTER.INJECTOR	6	
03	193736	14	O型密封圈	SEAL.O RING	18	
03	203426	15	滚针	PIN.ROLL	12	
03	3008706	12	滤网	SCREEN.FILTER	6	
03	3012536	18	量杯	CUP.INJECTOR	6	
03	3018325	4	柱塞副总成	PLUNGER	6	
03	3045047	11	量孔塞	PLUG.INJECTOR ORIFICE	6	
02	3032392		喷咀器安装	MTG.INJECTOR	6	
03	180626		衬圈	WASHER.INJECTOR CLAMP	6	
03	191916	3	喷油器柱塞连杆	LINK.INJECTOR PLUNGER	6	
03	3028279	1	十二角螺栓	SCREW.TWELVE POINT CAP	12	
03	3031137	2	压板	CLAMP.INJECTOR	6	

图-24 发电机及安装

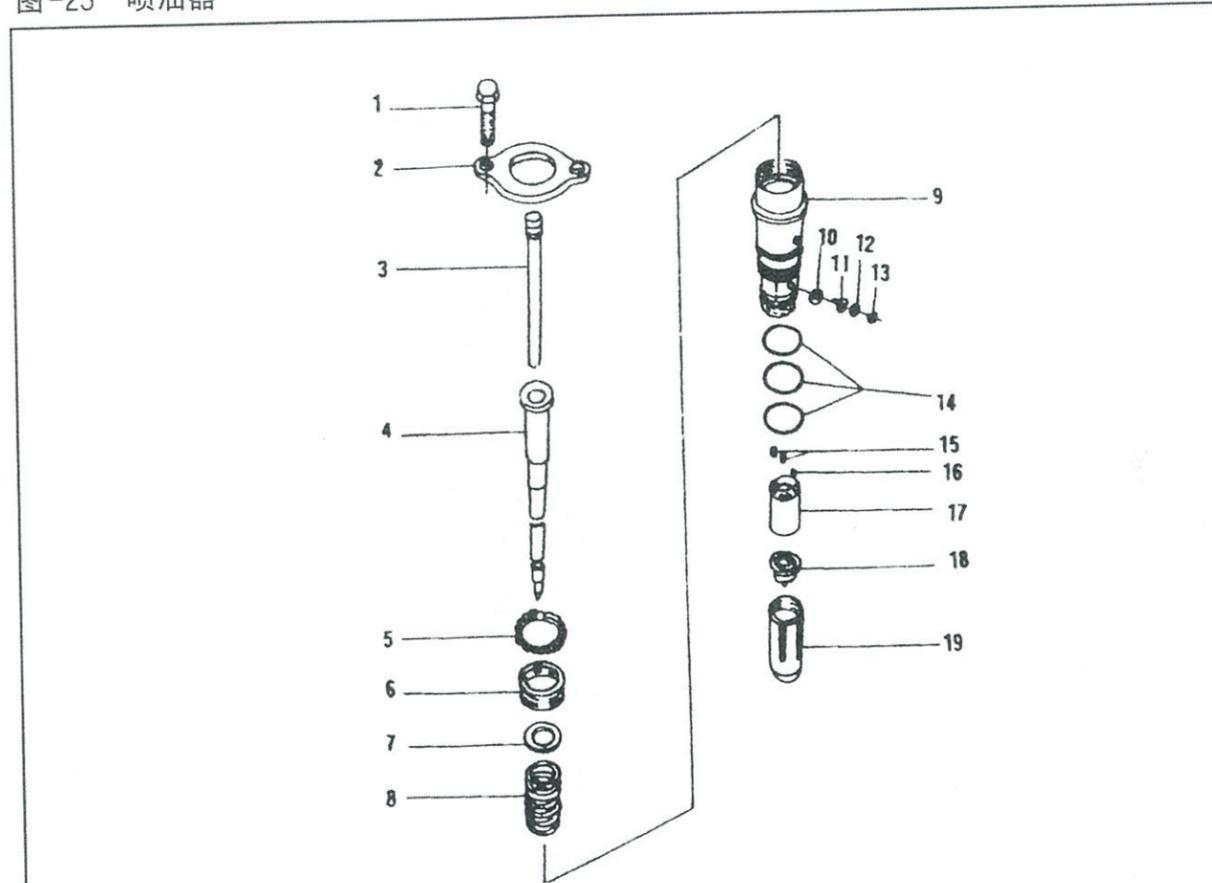

表-23

级别	零件号	图上标号	零件名称		数量	备注
			中文	英文		
02	3016627	6	交流发电机	ALTERNATOR	1	
03	S116C	1	六角螺栓	SCREW,HEXAGON HEAD	1	
03	S125	12	六角螺栓	SCREW,HEXAGON HEAD	1	
03	S608	2	弹簧垫圈	WASHER,LOCK	1	
03	66945	5	安装隔套	SPACER, MTG	1	
03	158829		六角螺栓	SCREW,HEXAGON HEAD	1	
03	203310	3	平垫圈	WASHER,PLAIN	3	
03	203760	7	平垫圈	WASHER,PLAIN	1	
03	70897	8	螺母	NUT	1	
03	218505	10	发电机支架	SUPPOORT,ALTERNATOR	1	
03	3012471	9	带垫螺栓	SCREW,CAPTIVE WAS	1	
03	3012472	11	带垫螺栓	SCREW,CAPTIVE WAS	2	
03	3029085	4	调节拉杆	LINK,ADIUSTING	1	
02	3040303		多槽皮带	BELT, V	2	
02	213326	13	发电机皮带轮	PULLEY,ALTERNATOR	1	

图-25 水滤器及座

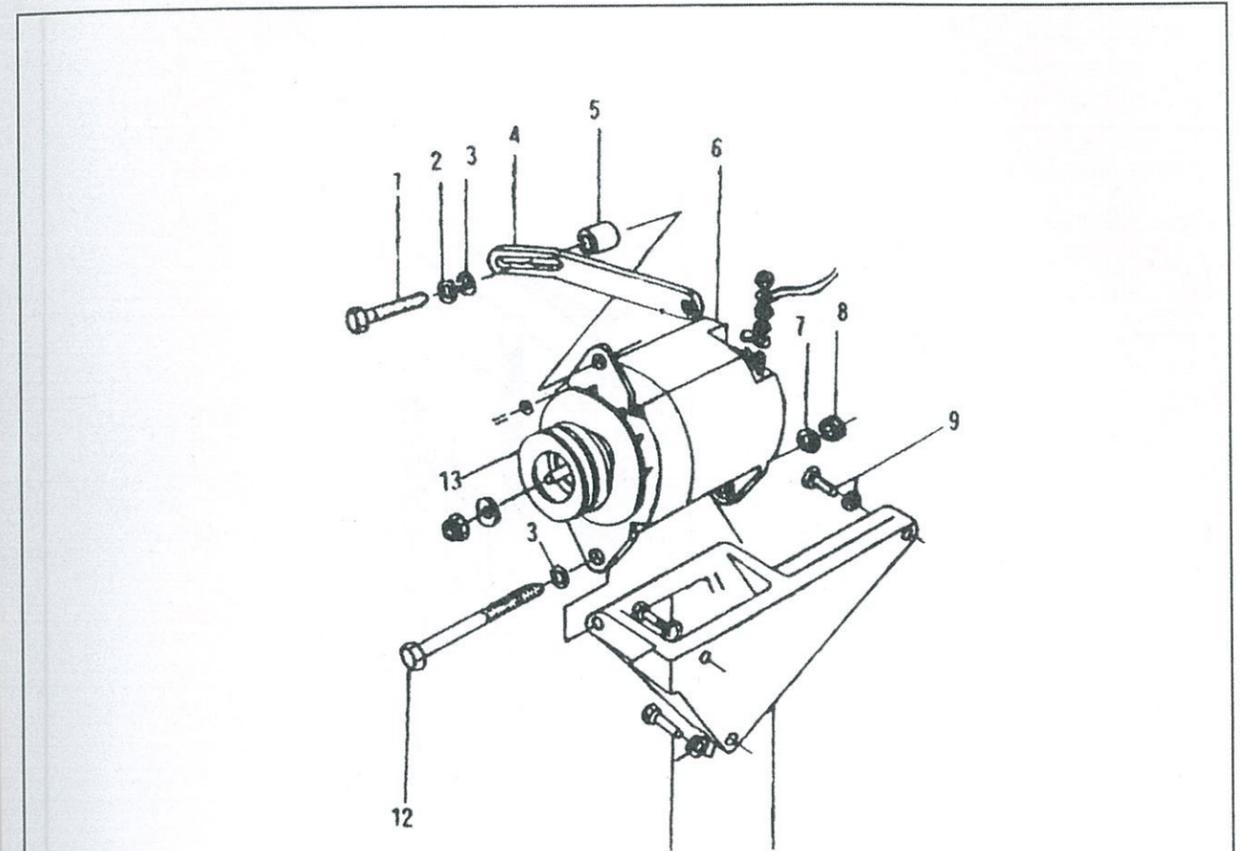

表-25

级别	零件号	图上标号	零件名称		数量	备注
			中文	英文		
01	WF1101		水滤器	CORROSION RESISTOR	1	
02	179912	7	软管	HOSE,PLAIN	1	
02	3016442		水滤器安装	CORROSION RESISTOR MTG	1	
03	179903	3	软管弯接头	COUPLING,ELBOW HOSE	2	
03	187317	5	接头	ADAPTOR,PLAIN	2	
03	258265		水滤器及座	CORROSION,RESISTOR W/HEAD	1	
04	204163	10	水滤器座	HEAD,RESISTOR CORROSION	1	
04	3318319	1	水滤器	CORROSION,RESISTOR	1	
02	179910	7	软管	HOSE,PLAIN	1	
02	3025600		水滤器安装	MTG,CRN RESISTOR	1	
03	70470		异径弯接头	ELBOW,STREET	2	
03	179901	6	切断阀	VALVE,SHUTOFF	2	
03	179904	4	软管夹	CLAMP,HOSE	4	
03	180221		管接头	ADAPTOR,PLAIN PIPE	1	
03	3010596	8	带垫螺栓	SCREW,CAPTIVE WASHER	4	
03	211448	9	水滤器支架	BRACKET,CRN RESISTOR	1	

图-26 飞轮齿圈及飞轮壳

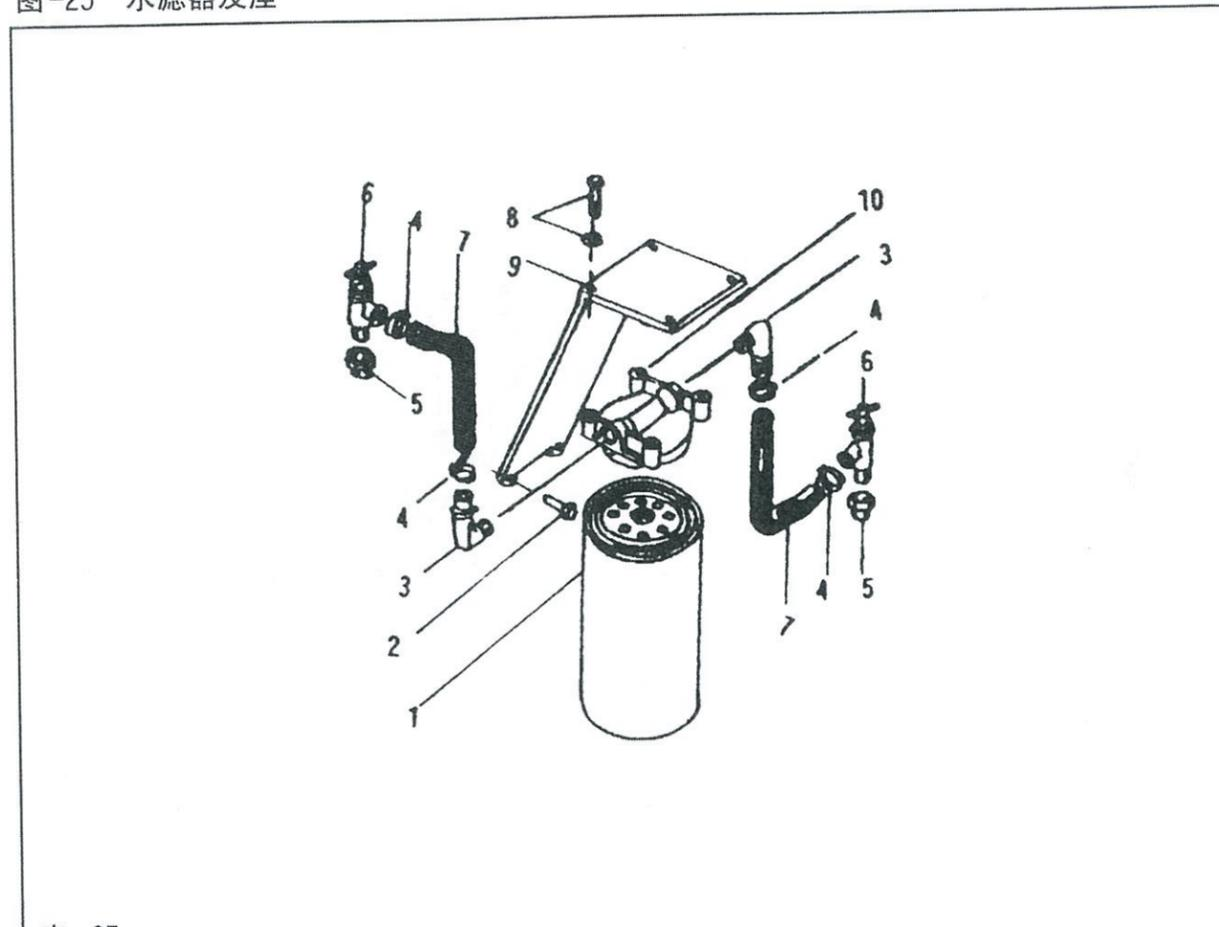

表-26

级别	零件号	图上标号	零件名称		数量	备注
			中文	英文		
02	3005557	1	飞轮壳	HOUSING,FLYWHEEL	1	
02	3008087		飞轮壳安装件	HOUSING,FLYWHEEL MTG		
03	138042	3	六角螺栓	SCREW,HEXAGON HEAD	9	
03	127316	2	平垫圈	WASHER,PLAIN	9	
03	60408	7	销钉	DOWEL,PIN	2	
02	3023510	4	飞轮及齿圈	FLYWHEEL	1	
02	MP2489		飞轮安装	FLYWHEEL MTG		
03	200861	5	平垫圈	WASHER,PLAIN	6	
03	204165	6	六角螺栓	SCREW,HEXAGON HEAD	6	

图-27 起动马达及继电器

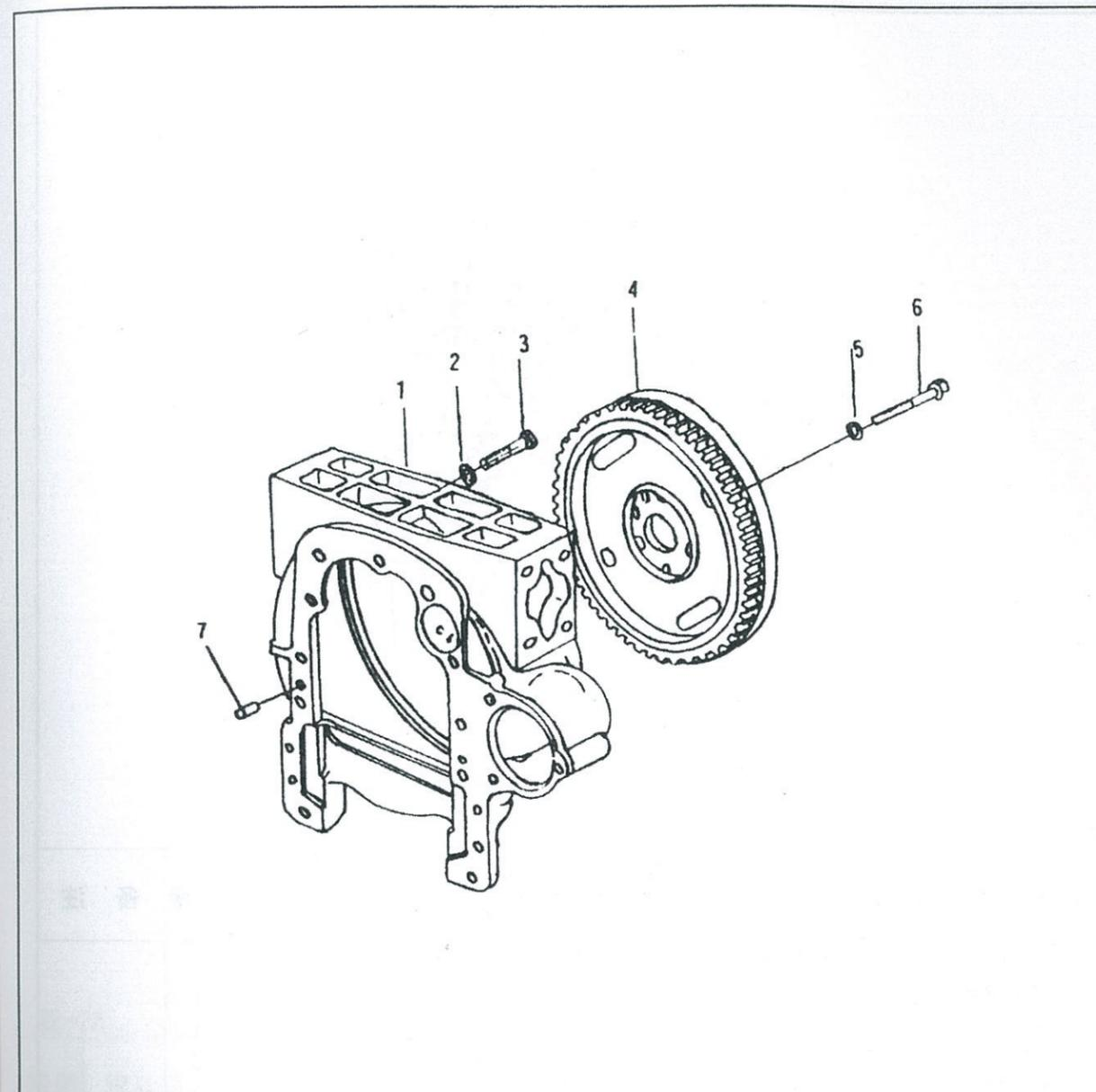

表-27

级别	零件号	图上标号	零件名称		数量	备注
			中文	英文		
02	3021036	1	起动马达	MOTOR,STARTING	1	
02	3018924	-	接地线	WIRE,GROUND	1	
02	MP1106	-	起动马达安装组件	MOTOR,STARTING MOUNTING	1	
03	S603	-	弹簧垫圈	WASHER,LOCK	3	
03	153581	-	十二角螺栓	SCREW,TWELVE POINT CAP	2	
03	153582	3	十二角螺栓	SCREW,HEXAGON HEAD	1	
02	9245	2	起动马达隔套	SPACER,STARTING MOTOR	1	
02	3050692	7	磁力开关	SWITCH,MAGNETIC	1	
02	3005711	-	磁力开关安装件	SWITCH,MAGNETIC	1	
03	S114	8	六角螺栓	SCREW,HEXAGON HEAD	2	
03	S258	4	六角螺母	NUT,HEAUY HEXGON	2	
03	S600	5	弹簧垫圈	WASHER,LOCK	2	
03	S631	-	平垫圈	WASHER,LOCK	4	
03	3062483	6	安装支架	BRACKET,MAGNETIC	1	

图-28 燃油滤清器

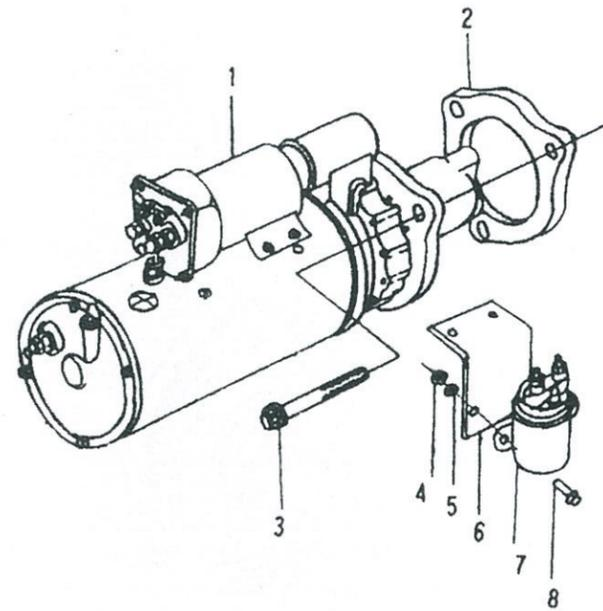

表-28

级别	零件号	图上标号	零件名称		数量	备注
			中文	英文		
02	BM79866	-	燃油滤清器座及接头	FIL TER,FUEL	1	
03	129859	5	弯管接头	ELBOW,MALE UNION	2	
03	3418763	7	燃油滤清器座	HEAD,FUEL FILTER	1	
02	MP45084	-	燃油滤清器支架安装	BRACKET,FUEL FILT MTG	1	
03	S120A	-	六角螺栓	SCREW,HEXAGON HEAD	1	
03	S602	-	平垫圈	WASHER,HEXAGON HEAD	1	
03	108330	-	平垫圈	WASHE,PLAIN	1	
03	3010596	1	带垫螺栓	SCREW,CAPTIVE WASHER	4	
03	3011380	2	滤清器支架	BRACKET,FILTER	1	
03	3034526	4	带垫螺栓	SCREW,CAPTIVE WASHER	2	
02	3315843	8	燃油滤清器	FILTER,FULE	2	
03	251345	-	燃油滤清器	FILTER,FULE	2	
04	255622	9	密封环	SEAL,RECTANGULR RING	2	
02	AS10022SS	6	软管	HOSE,FILEXIBLFE	1	

图-29 仪表板

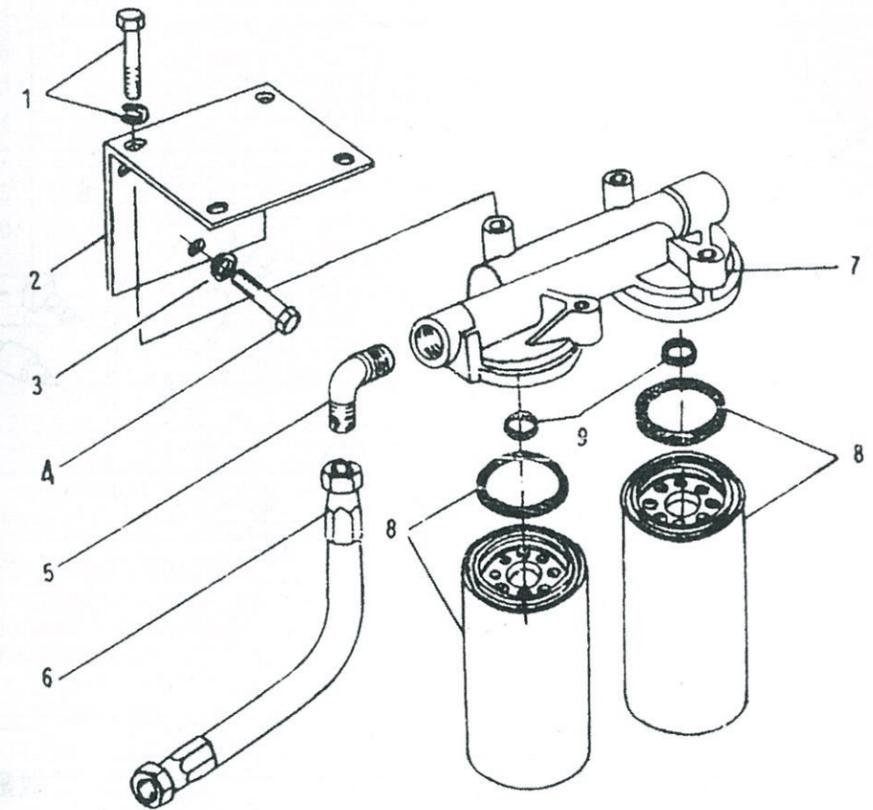

表-29

级别	零件号	图上标号	零件名称		数量	备注
			中文	英文		
02	3015237		油压传感器	OIL PRESSURE TRANSDUCER	1	
02	3015238		温度传感器	TEMP,TPANSDUCER	2	
02	3062865		导线	HARNESS,WIRING	1	
02	3056344		压力报警开关	SWITCH,PRESSURE	1	
02	3056353		温度报警开关	TEMP,SWITCH	1	
02	3036453		超速开关板	SWITCH,OVERSPEED	1	
02	3063683		导线	HARNESS,WIRING	1	
02	3037221		仪表板支架	BRACKET,INSTRUMENT PANEL	1	
03	3053010		仪表盒	CABINET,INSTRUMENT	1	
03	3053065		线路板	BOARD,CIRCUIT	1	
03	3035132		导线	HARNESS,WIRING	1	
02	3034572		电磁传感器	PICKUP,MAGNETI	1	
02	3062654		仪表板	PANEL,INSTRUMENT	1	
03	102057		三位开关	THREE,SWITCH	1	
03	3035150	1	启动按钮	START BDLTTON	1	
03	104215	2	跳动式开关	SWITCH,TOGGLE	1	
03	3015105		电位器	POTENTIOMETE	1	
03	3015235	4	电压表	VOLTMETER	1	
03	3015233	5	(水)温度表	TEMPREATURE GAUGE	1	
03	3015234	6	(油)温度表	TEMPREATURE GAUGE	1	

续表-29

级别	零件号	图上标号	零件名称		数量	备注
			中文	英文		
03	3015232	7	压力表	GUAGE,PRESSURE	1	
03	3031734	8	转速表	TACHOMETER	1	
03	3035766	3	小时计	HOURLMETER	1	
03	3034953		断路器	BRACKER,CIRCUIT	1	
03	3053044		导线	HARNESS,WIRING	1	
03	3053077	10	仪表板	PANEL,INSTRUMENT	1	
03	3044195		电子调速器控制板	ELECTRIC GOVERNOR CONTROL	1	常闭式
03	3053060		指示灯线路板	BOARD,CIRCUIT	1	

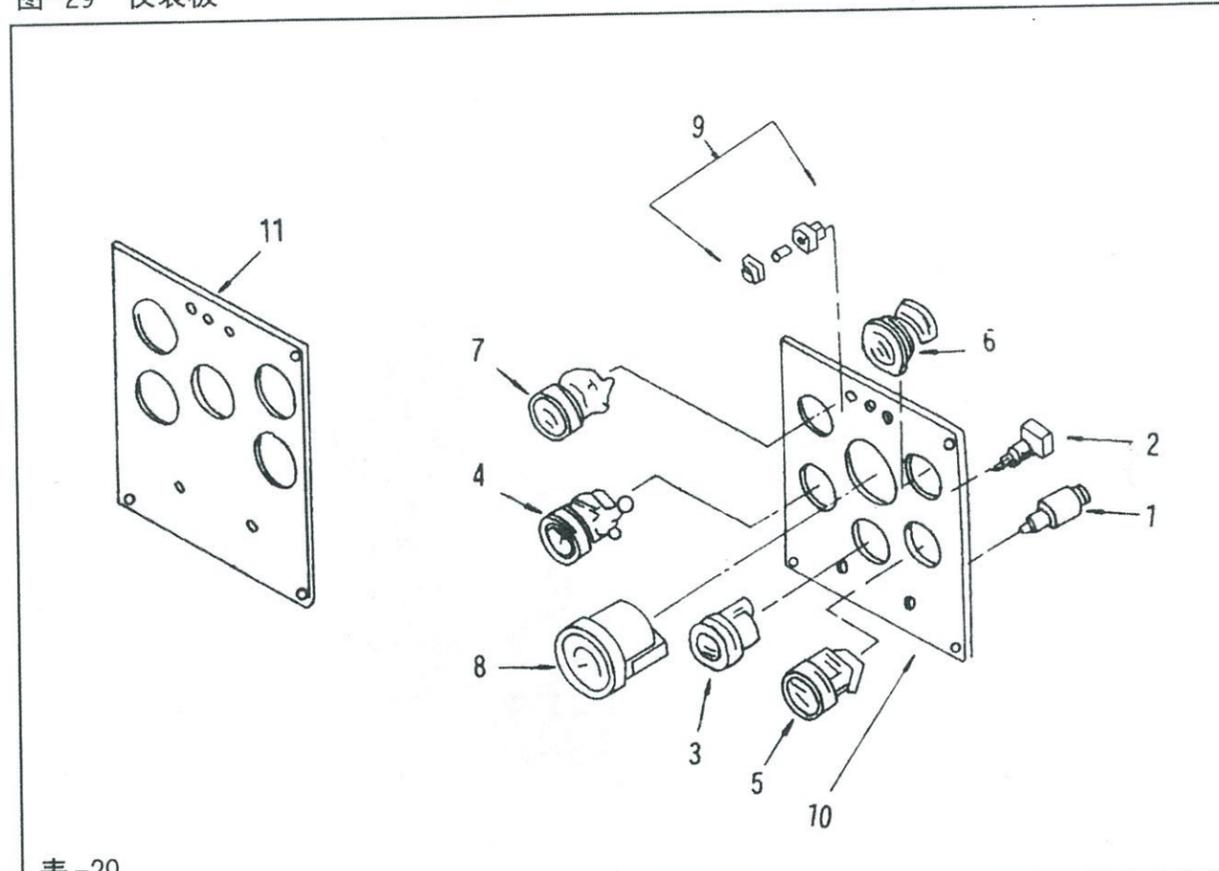
图-30 水箱



表-30

级别	零件号	图上标号	零件名称		数量	备注
			中文	英文		
02	3419015	1	散热器(水箱)	RADIATOR	1	
03	3419059	2	导风圈	SHROUD,FAN	1	
03	3011301	3	风扇防护板	FANEL,FAN GUARD	2	
03	3419052	4	风扇防护罩	FANEL,FAN GUARD	1	
03	3419053	5	风扇防护罩	FANEL,FAN GUARD	1	
02	3419054		风扇安装	FAN&SPACER MTG	1	
03	3005589		风扇导向隔套	SPACER,FAN PILOT	1	
03	3005592		风扇隔套衬垫	GASKET,FAN SPACER	1	
03	3035776		风扇隔套	SPACER,FAN	1	
03	3418764		风扇	FAN,ENGINE	1	

图-31 机油旁通滤清器

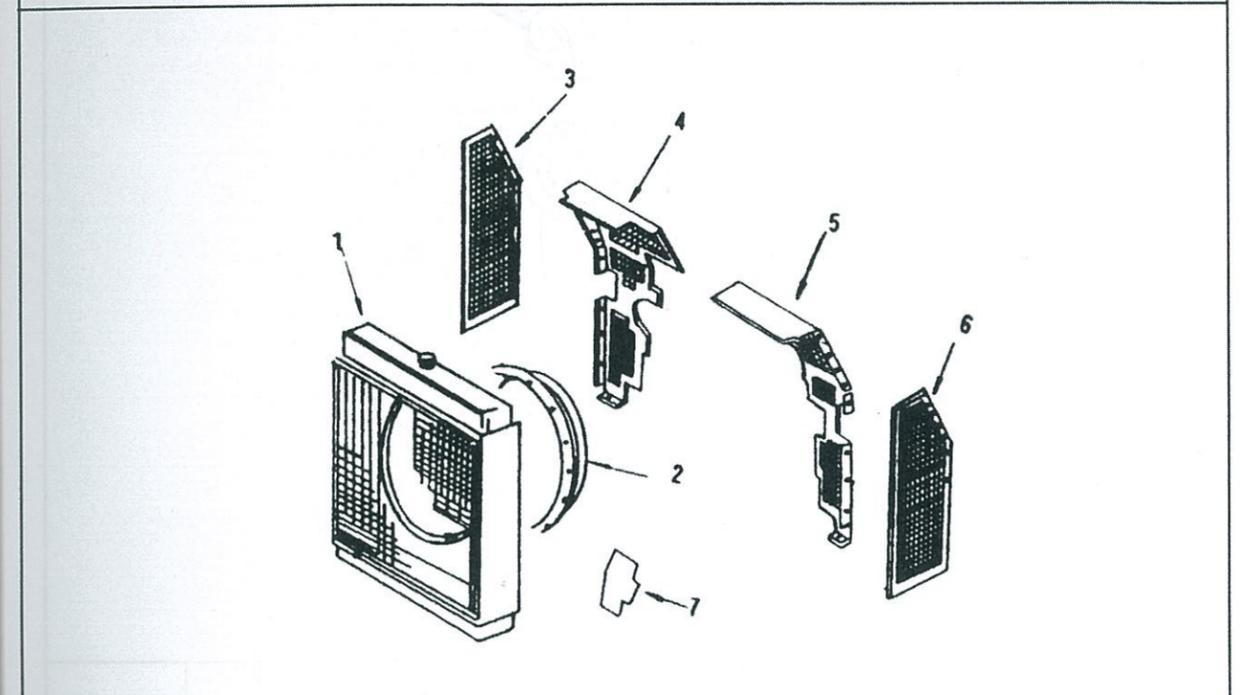

表-31

级别	零件号	图上 标号	零件名称		数量	备注
			中 文	英 文		
02	3313283	1	旁边通滤清器总成	ELEMENT, LUB OIL FILTER	1	
02	3418762	2	滤清器座	HEAD, LUB OIL FILTER	1	
03	Q1501030	3	螺栓	SCREW, HEXAGON HEAD	3	
03	108707	4	弹簧垫圈	WASHER, LOCK	3	
03	S223	5	螺母	NUT, HEAVY HEXAGON	3	
03	AS6032SS		软管	HOSE, FLEXIBLE	1	
03	AS6036SS		软管	HOSE, FLEXIBLE	1	
03	S1040A		弯接头	ELBOW, MALE ADAPTER	1	
03	68645		弯接头	ELBOW, MALE ADAPTER	2	
03	144378		弯接头	ELBOW, MALE ADAPTER	1	
02	3418929		支架	BRACKET FILTER	1	
03	Q1501030		螺栓	SCREW, HEXAGON HEAD	2	
03	Q34010		螺母	NUT, HEAVY HEXAGON	2	

地 址: 重庆市沙坪坝区壮志路 (烈士墓)
电 话: 023-65335888 (总机)
023-65333444 (服务热线)
电 报: 0221 (重庆)
传 真: 023-65315379
邮 编: 400031
零件号: 3166120 Rev00
CCEC 文印中心印刷

ADD: ZHUANGZHI ROAD, SHAPINGBA, CQ
PHONE: 023-65335888
023-65333444
CABLE: 0221 (CQ)
Fax: 023-65315379
P.C: 400031
PARTS NO: 3166120 Rev00

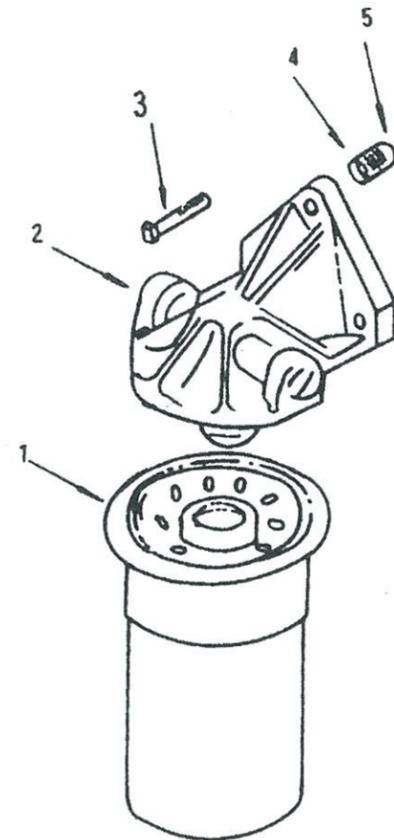
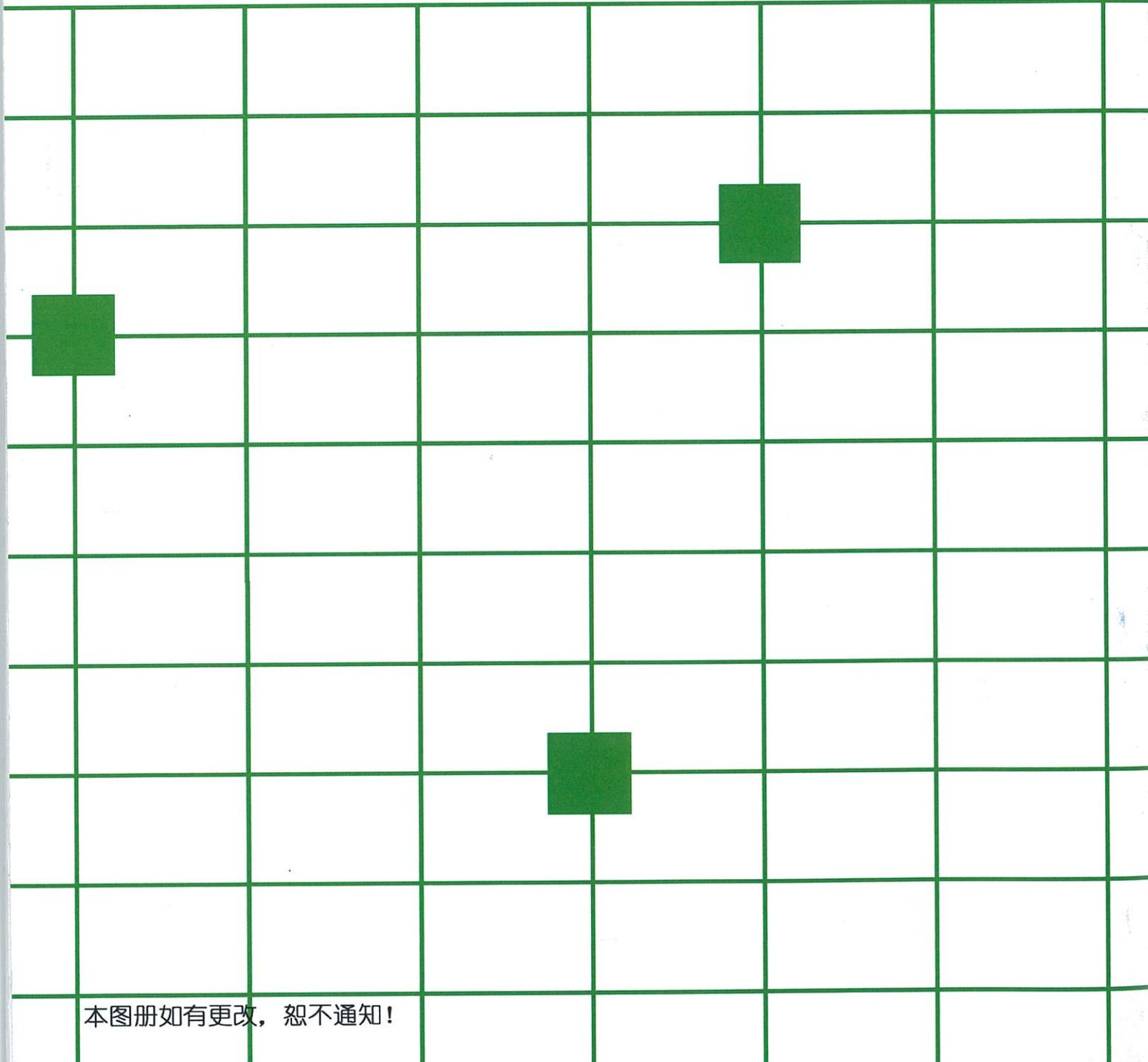

本图册如有更改, 恕不通知!