

# 前 言

为使4M06 系列柴油机在使用、维护等工作上的方便，特汇编本图册，以供我方与用户在使用中查阅参考。

该图册基本上按组绘出了各个零件的装配关系。图序号、件号、数量、中文名称、英文名称等列于明细表栏内。图册包含发动机详细的装机明细，其中部分零件为不可销售配件，如欲了解配件销售事宜可咨询潍柴备品公司。

随着技术和生产的不断发展，柴油机的变形将增多，故本图册的内容将有所更新。变化不再另行通知，特请用户注意。本产品的售后服务统一授权潍柴动力股份有限公司执行，用户可通过[www.weichai.com](http://www.weichai.com)网站访问获取相关产品信息。

## FOREWORD

This illustrated parts manual is specially prepared for customers to facilitate the use of 4M06 series diesel engine in operation and tenance.

The illustrations are grouped under the heading of each assembly and numbered individually.Part.

No.,Quantity,Model,English designation,Chinese designation and so on are written in the parts list . The parts catalogue include detailed assembling parts list of diesel engine ,some parts can not be sold ,if you want to know selling part matters,please ask weichai power spare part resource CO.,LTD.

With the development of technology and production,the versions of the diesel engine will be increased, so the catalogue will be revised.Please pay attention to our revised edition.After service of this product is authorized to Weichai Power Co.,Ltd ,Consumers can acquire information of this product through [www.weichai.com](http://www.weichai.com).

# 目 录 CONTENTS

<b>机体结合组(Engine Block Group)</b> .....	<b>1</b>
机体总成(crankcase assembly) .....	3
机体预装配(crankcase pre-assembly) .....	5
<b>油封结合组(Oil Seal Group)</b> .....	<b>7</b>
<b>飞轮壳结合组(Flywheel Housing Group)</b> .....	<b>9</b>
<b>齿轮室罩壳结合组(Gear Housing Cover Group)</b> .....	<b>11</b>
<b>齿轮室结合组(Gear Housing Group)</b> .....	<b>13</b>
<b>曲轴结合组(Crankshaft Group)</b> .....	<b>15</b>
<b>主轴瓦结合组(Main Bearing Group)</b> .....	<b>17</b>
<b>止推片结合组(Thrust Plate Group)</b> .....	<b>19</b>
<b>飞轮结合组(Flywheel Group)</b> .....	<b>21</b>
飞轮总成(Flywheel Assembly).....	23
<b>活塞连杆结合组(Piston and Connecting Rod Group)</b> .....	<b>25</b>
活塞环组件(Piston Ring Set) .....	27
连杆总成(Connecting Rod Assembly) .....	29
<b>气缸盖结合组(Cylinder Head Group)</b> .....	<b>31</b>
气缸盖分总成(Cylinder Head Subassembly).....	33
<b>气缸盖前盖板结合组(Cylinder Head Front Cover Group)</b> .....	<b>35</b>
<b>吊环结合组(Eye Ring Group)</b> .....	<b>37</b>
<b>气缸盖罩结合组(Cylinder Head Cover Group)</b> .....	<b>39</b>
加机油口盖组件() .....	41
<b>配气机构结合组(Valve Train Group)</b> .....	<b>43</b>
整体式摇臂轴总成(Integrated Rocker Arm Shaft Assembly).....	45
<b>齿轮传动结合组(Gear Drive Group)</b> .....	<b>47</b>
<b>曲轴皮带轮结合组(Crankshaft Pulley Group)</b> .....	<b>49</b>
<b>油底壳结合组(Oil Pan Group)</b> .....	<b>51</b>
放油螺塞(Oil Drain Plug).....	53
<b>油标尺结合组(Oil Dipstick Group)</b> .....	<b>55</b>
<b>机油泵结合组(Oil Pump Group)</b> .....	<b>57</b>

机油集滤器结合组(Oil Strainer Group) .....	59
机油滤清器结合组(Oil Filter Group).....	61
水泵结合组(Water Pump Group) .....	63
节温器结合组(Thermostat Group).....	65
散热器结合组(Radiator Group) .....	67
风扇及轮毂结合组(Fan and Hub Group) .....	69
喷油泵结合组(Fuel Injection Pump Group) .....	71
喷油泵润滑油管结合组(Fuel Injection Pump Oil Pipe Group).....	73
喷油器结合组(Fuel Injector Group).....	75
低压油管结合组(Low Pressure Fuel Pipe Group).....	77
燃油滤清器结合组(Fuel Filter Group).....	79
高压油管结合组(High Pressure Fuel Pipe Group) .....	81
高压油管总成(High-pressure Fuel Pipe Assembly).....	83
进气管结合组(Intake Manifold Group).....	85
空气滤清器结合组(Air Filter Group) .....	87
排气管结合组(Exhaust Manifold Group) .....	89
张紧轮及皮带结合组(Tensioner And Belt Group) .....	91
起动机结合组(Starter Motor Group).....	93
发动机支架结合组(Engine Bracket Group) .....	95
主机外围附件支撑结合组(Engine Peripheral Device Support Group) .....	97
随机备件结合组(Spare Parts Attached to Engine Group) .....	99
发电机结合组(Alternator Group).....	101
零件箱结合组(Parts Box Group) .....	103



# 机体结合组(Engine Block Group)

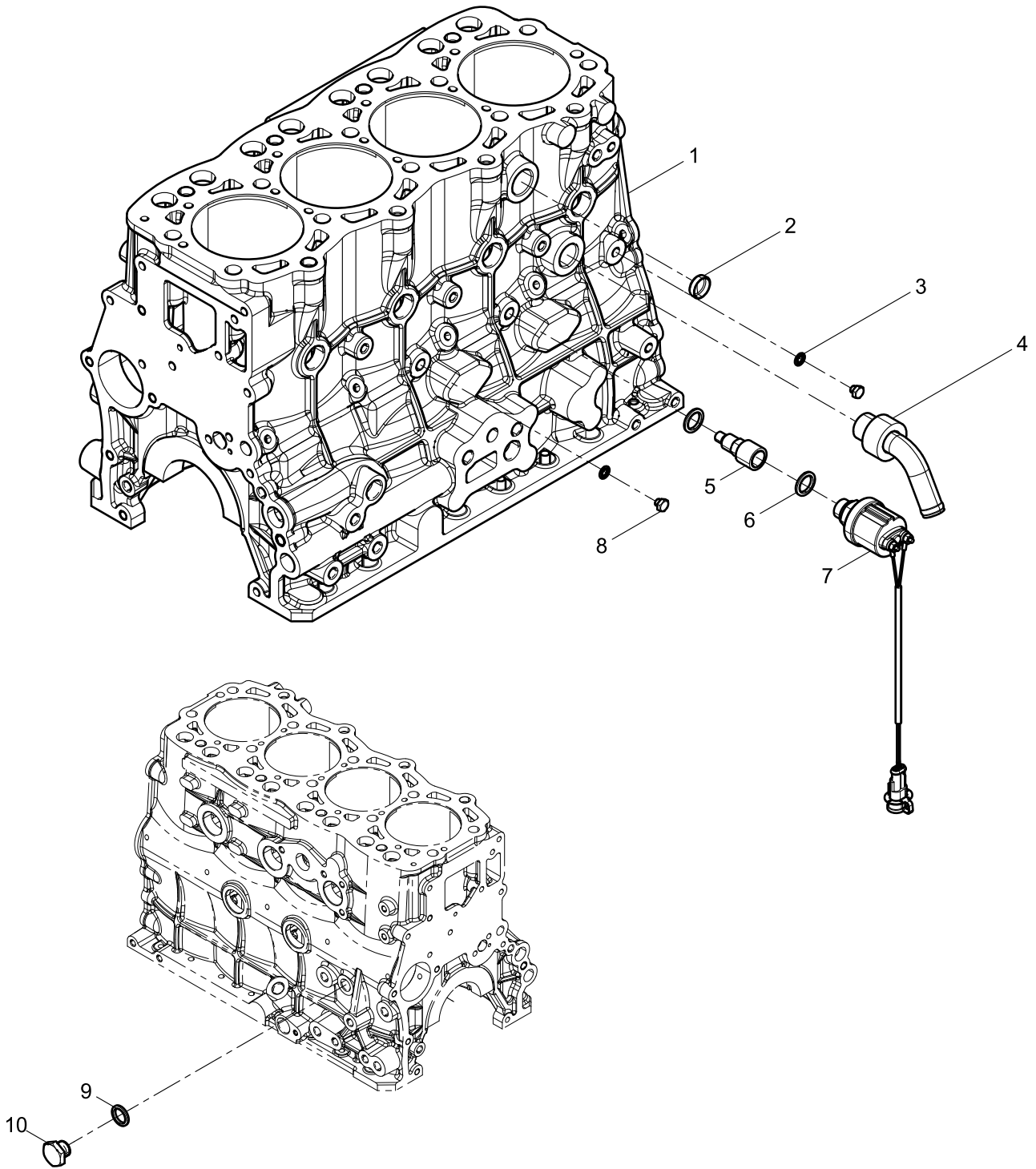



# 机体总成(crankcase assembly)

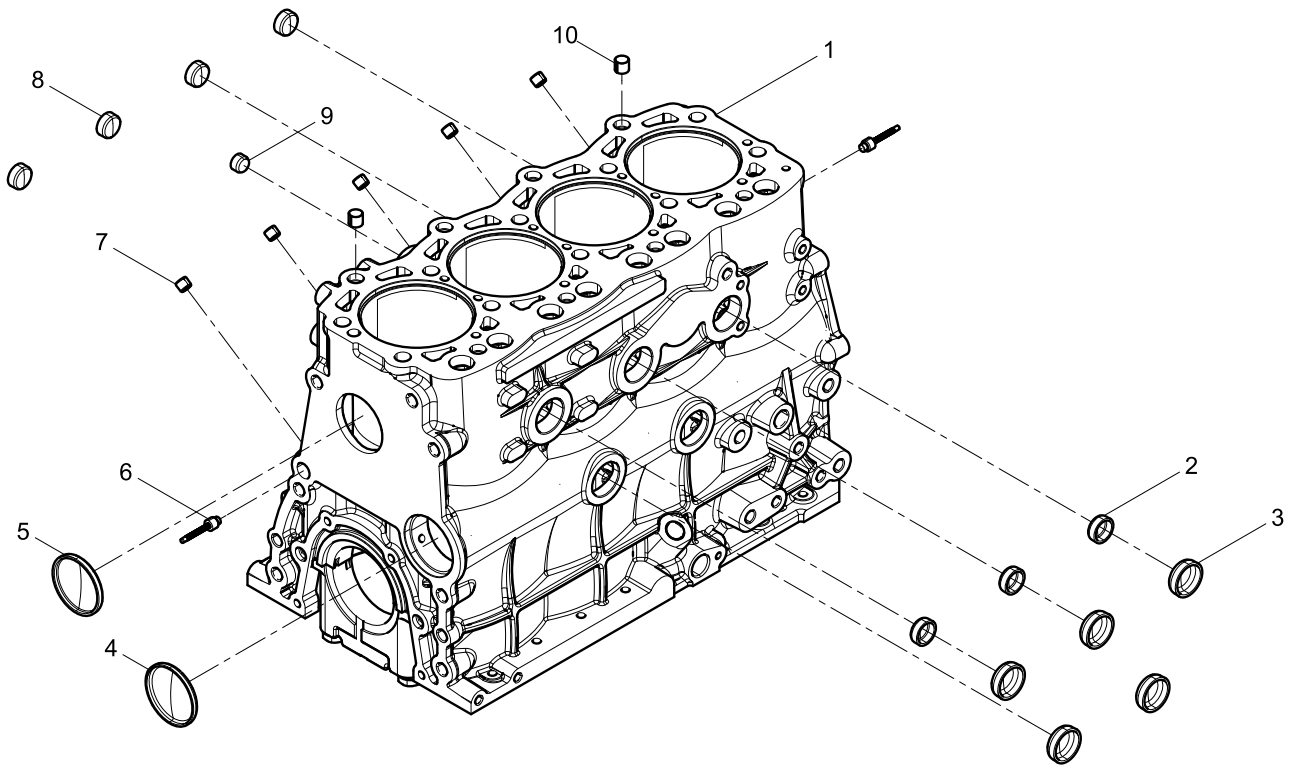

**机体总成(crankcase assembly)**

图序号 Pos.	件号 Teile.Number	数量 Amount	中文名称 Denomination	英文名称 Designation
1	1001437425	1	机体预装配	crankcase pre-assembly
2	2010128	3	密封塞	Sealer
3	2010232	5	碗形塞	Bowl Plug
4	2050101	1	凸轮轴孔堵塞	Camshaft Plug
5	2014523	1	堵塞	jam
6	331001000103	3	拉铆钉	Pulling Rivet
7	612600040228	5	拉铆钉	Pulling Rivet
8	2020331	4	堵塞	jam
9	1000615662	1	碗形塞	Bowl Plug
10	2020106	2	定位套	Dowel Pin



# 机体预装配(crankcase pre-assembly)

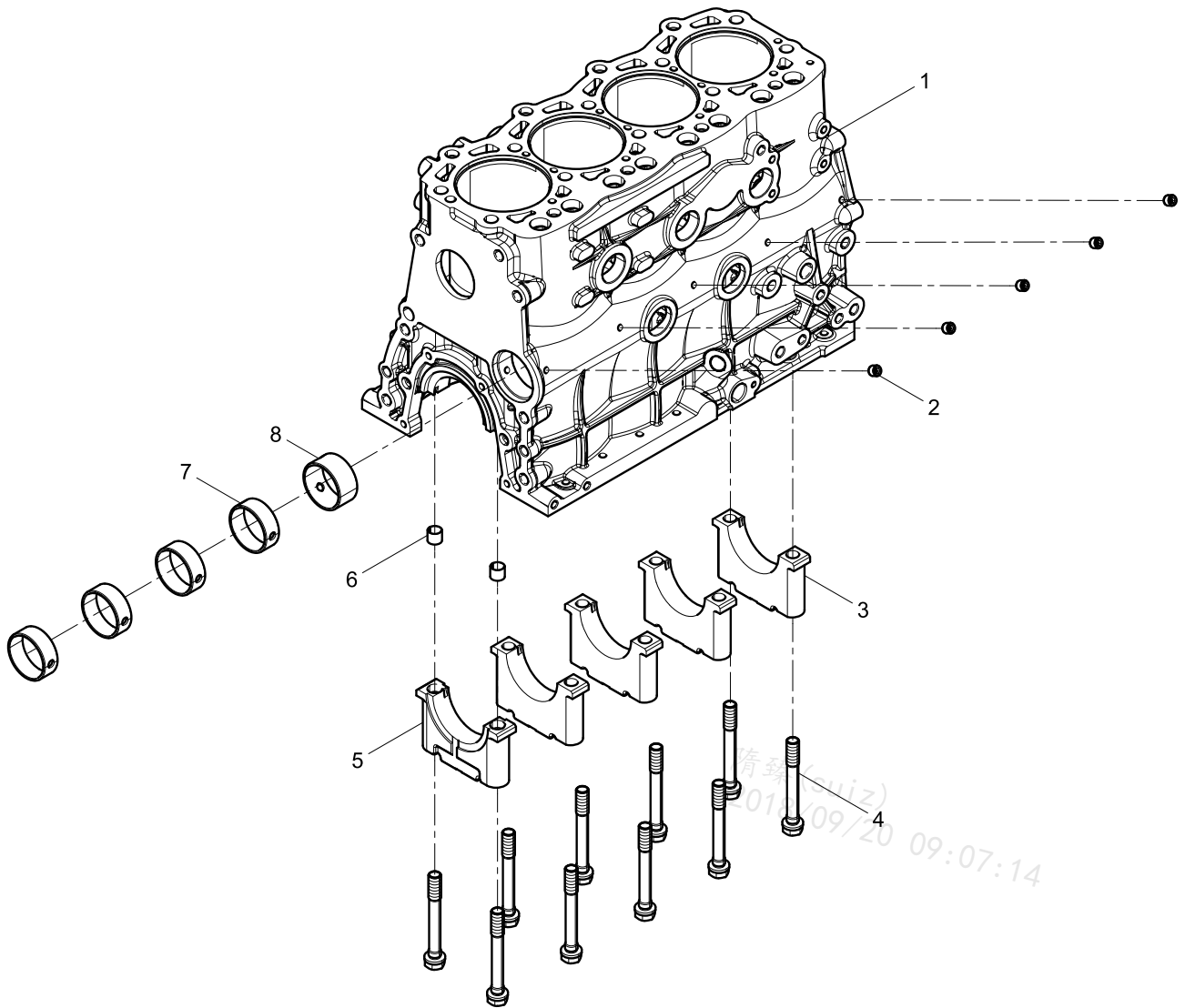



油封结合组(Oil Seal Group)

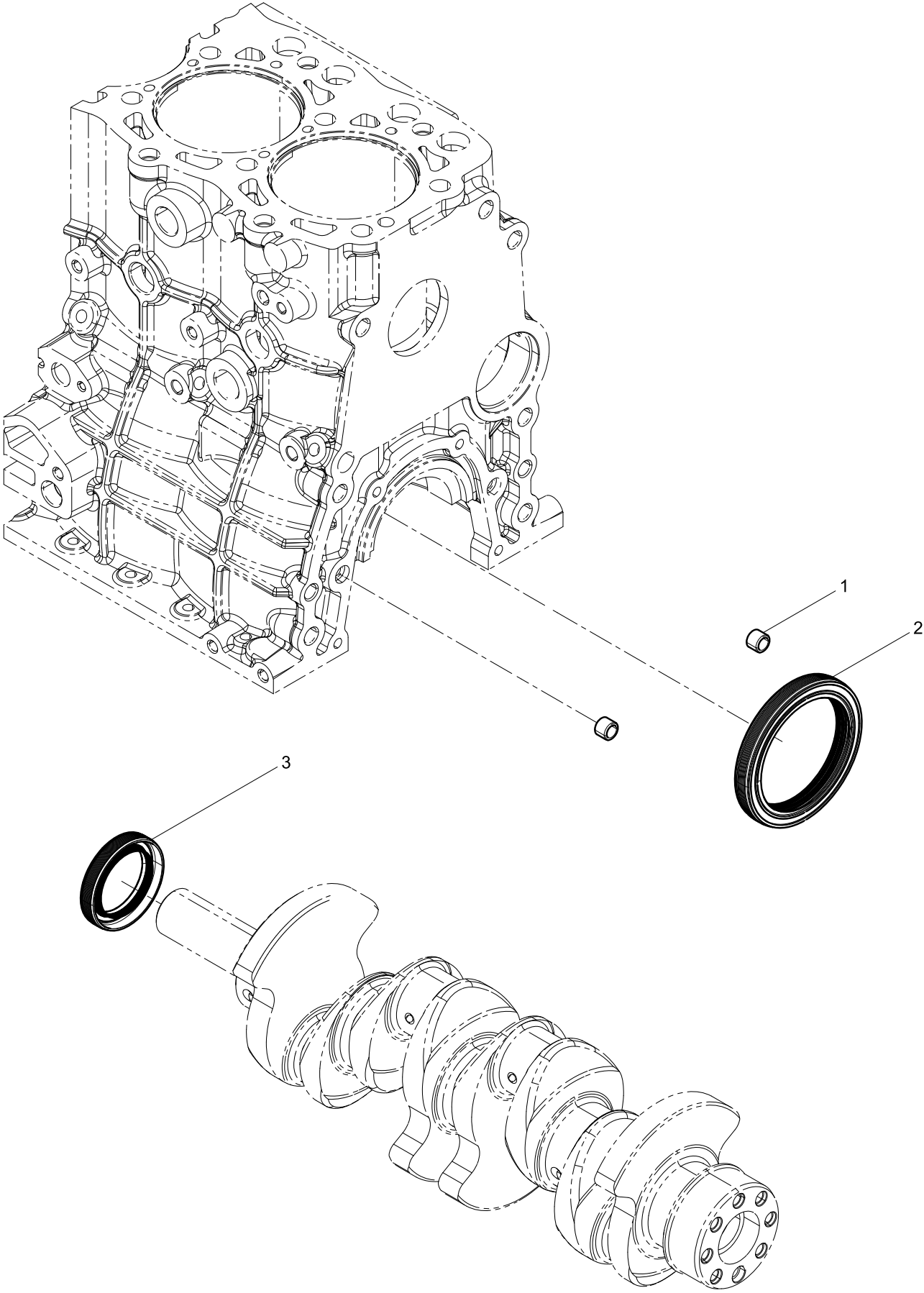

**油封结合组(Oil Seal Group)**

图序号 Pos.	件号 Teile.Number	数量 Amount	中文名称 Denomination	英文名称 Designation
1	2020191	2	定位套管	
2	2021942	1	后油封	Rear Oil Seal
3	2021995	1	前油封	Front Oil Seal

# 飞轮壳结合组(Flywheel Housing Group)

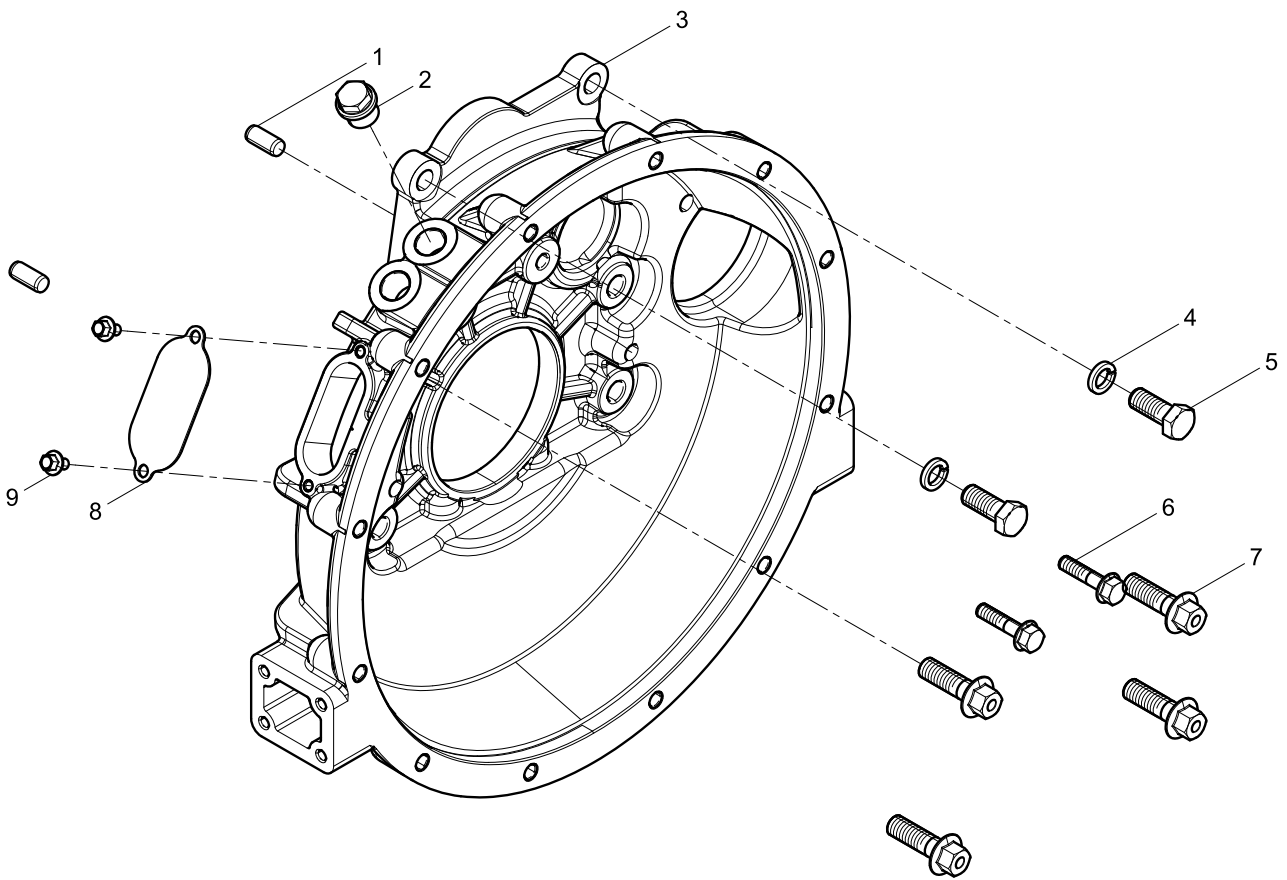

飞轮壳结合组(Flywheel Housing Group)

图序号 Pos.	件号 Teile.Number	数量 Amount	中文名称 Denomination	英文名称 Designation
1	2BYZX-D10X22	2	圆柱销	Parallel Pin
2	13022205	1	六角头螺塞	Hexagon Screw Plug
3	1001700167	1	飞轮壳	Flywheel Housing
4	90003931142	2	弹簧垫圈	Spring Washer
5	9000000896	2	六角头螺栓	Hexagon Head Bolt
6	90011400021	2	六角法兰面螺栓	Hexagon Flange Bolt
7	9000000045	6	六角法兰面螺栓	Hexagon Flange Bolt
8	2020162	1	飞轮壳窥视孔盖	
9	9000000048	2	六角法兰面螺栓	Hexagon Flange Bolt

# 齿轮室罩壳结合组(Gear Housing Cover Group)

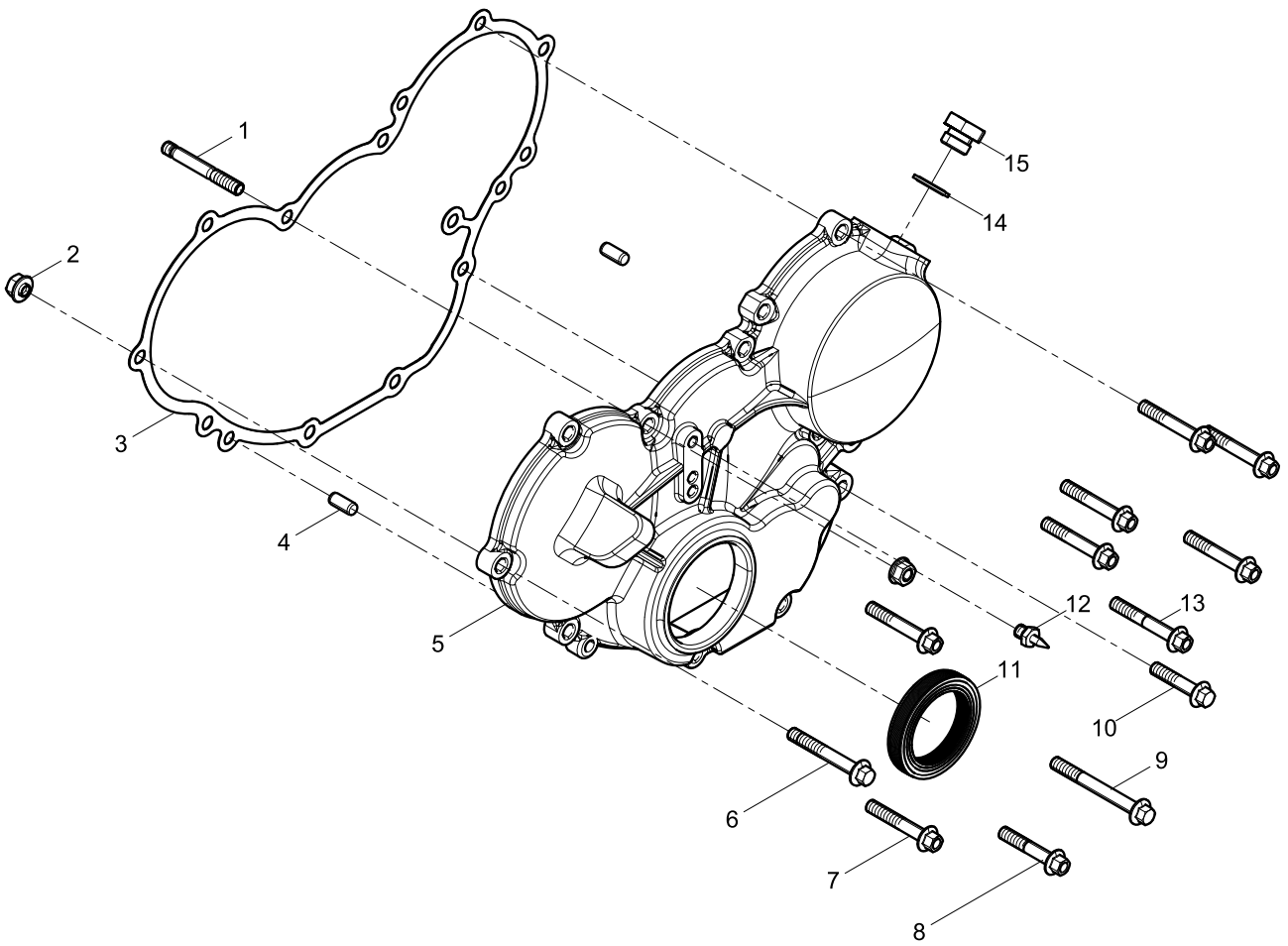

齿轮室罩壳结合组(Gear Housing Cover Group)

图序号 Pos.	件号 Teile.Number	数量 Amount	中文名称 Denomination	英文名称 Designation
1	90011620003	1	双头螺柱	Double End Stud
2	90012290001	2	六角法兰面螺母	Hexagon Flange Nut
3	1000616794	1	齿轮室罩壳垫片	Gear Housing Cover Gasket
4	90015050026	2	圆柱销	Parallel Pin
5	1001906885	1	齿轮室罩壳	Gear Housing Cover
6	90011410008	1	六角法兰面螺栓	Hexagon Flange Bolt
7	90011420024	7	六角法兰面螺栓	Hexagon Flange Bolt
8	9000000069	1	六角法兰面螺栓	Hexagon Flange Bolt
9	90011410009	1	六角法兰面螺栓	Hexagon Flange Bolt
10	90011410001	1	六角法兰面螺栓	Hexagon Flange Bolt
11	2021995	1	前油封	Front Oil Seal
12	2021158	1	正时指针	Index
13	90011410005	1	六角法兰面螺栓	Hexagon Flange Bolt
14	90014420001	1	组合密封垫圈	Assembled Sealing Washer
15	90003962030	1	六角螺塞	Hexagon plug



# 齿轮室结合组(Gear Housing Group)

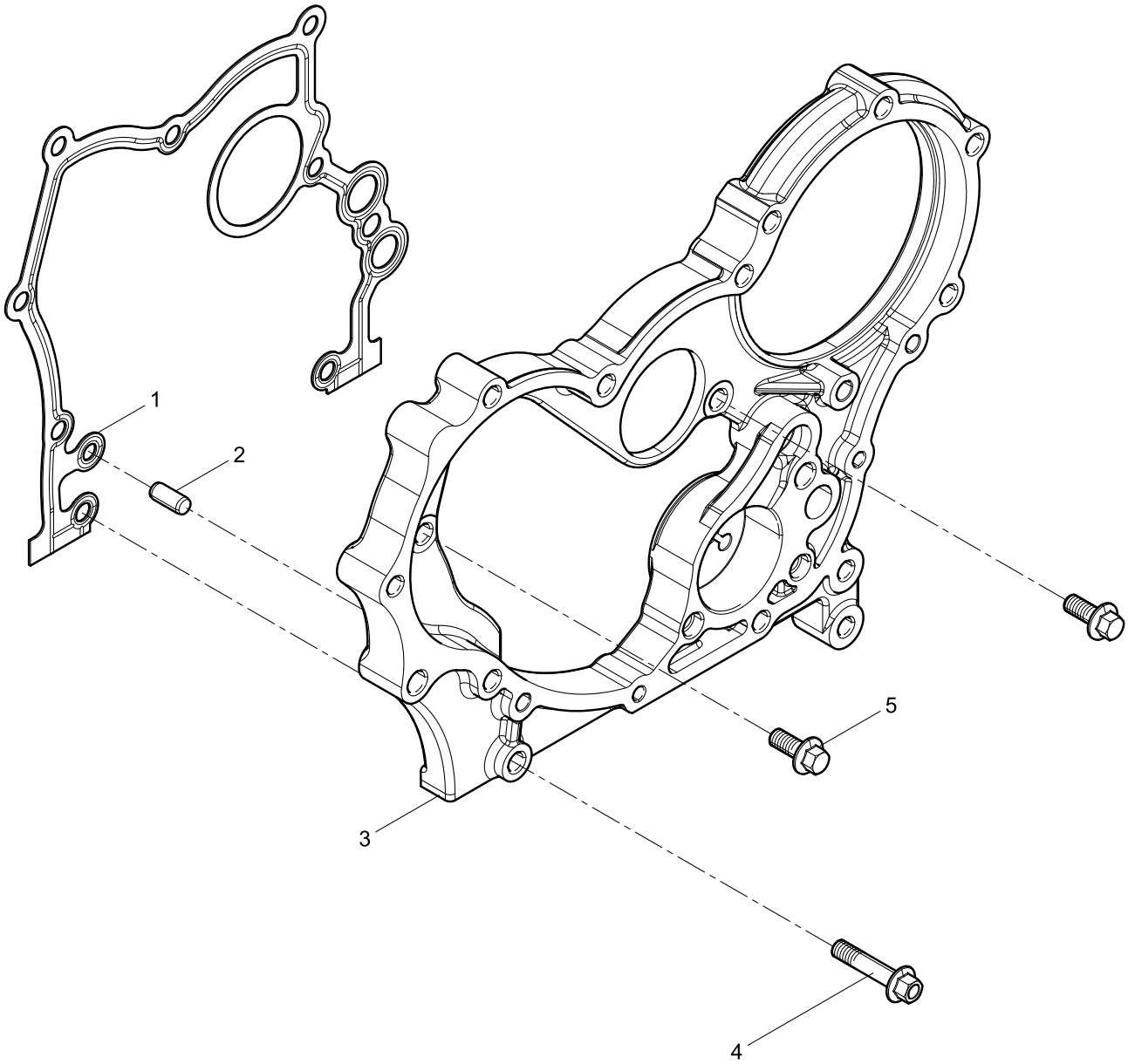

**齿轮室结合组(Gear Housing Group)**

图序号 Pos.	件号 Teile.Number	数量 Amount	中文名称 Denomination	英文名称 Designation
1	1000616214	1	正时齿轮室垫片	Timing Gear Chamber Gasket
2	90015050026	1	圆柱销	Parallel Pin
3	1001226075	1	正时齿轮室	Timing Gear Chamber
4	9000000186	1	六角法兰面螺栓	Hexagon Flange Bolt
5	90011410011	2	六角法兰面螺栓	Hexagon Flange Bolt

## 曲轴结合组(Crankshaft Group)

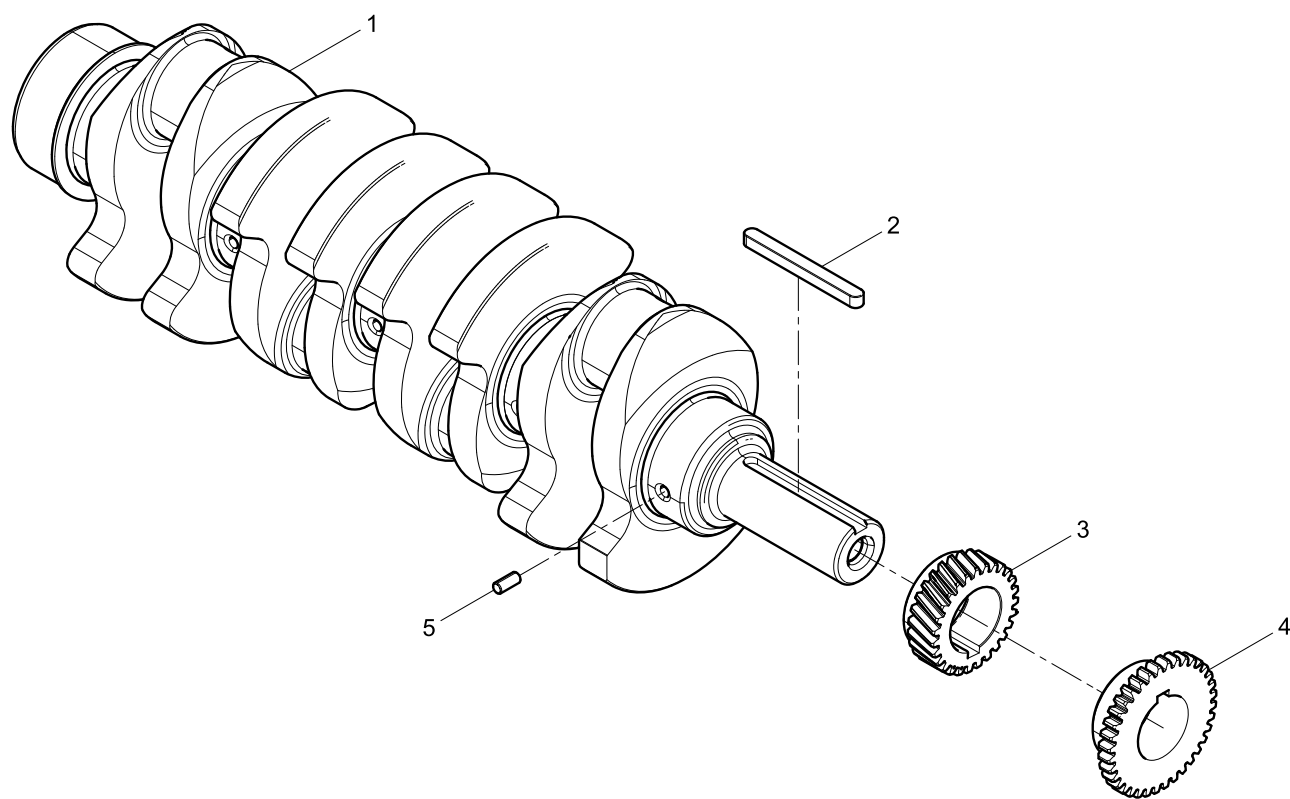



# 主轴瓦结合组(Main Bearing Group)

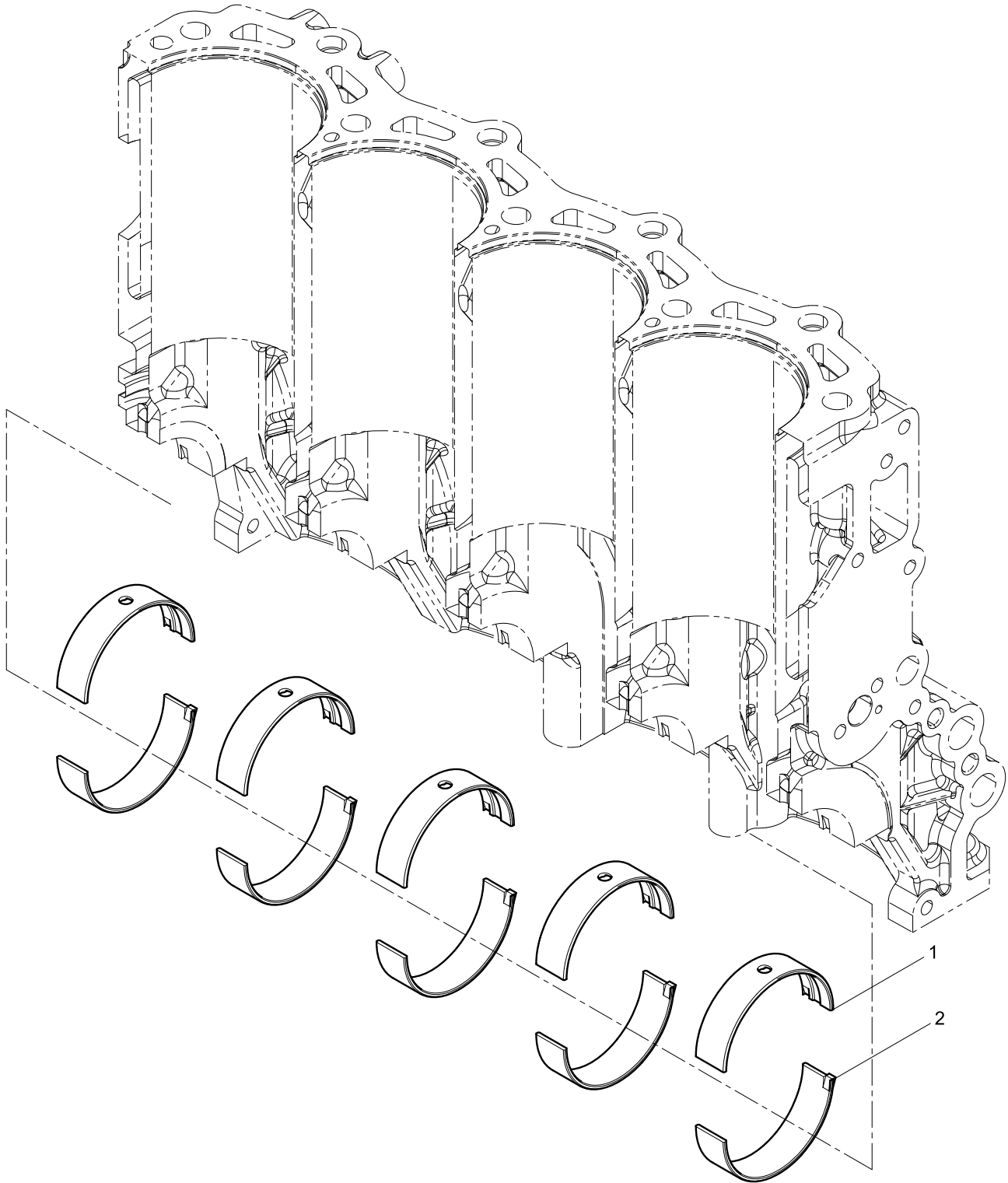



止推片结合组(Thrust Plate Group)

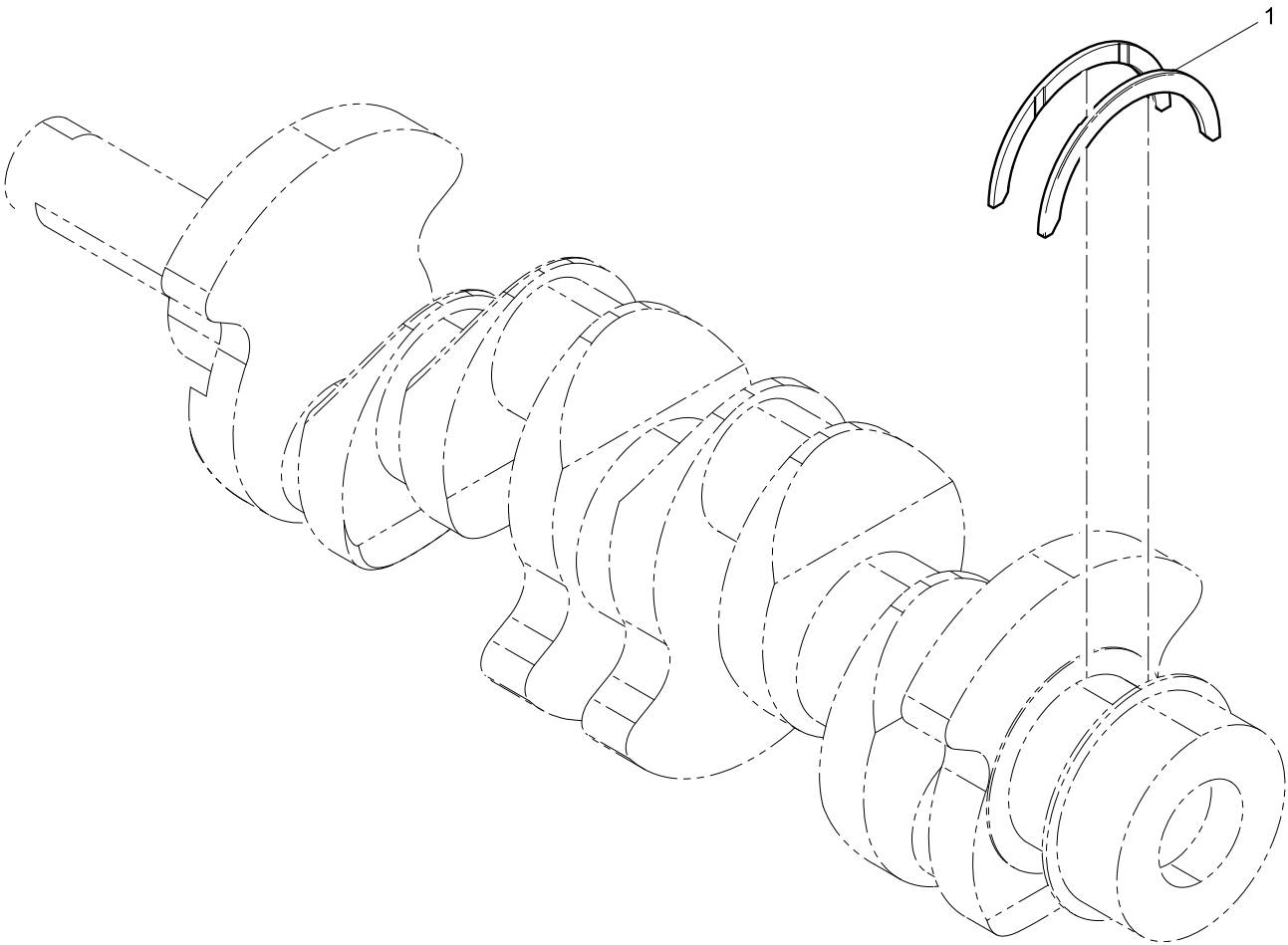





# 飞轮结合组(Flywheel Group)

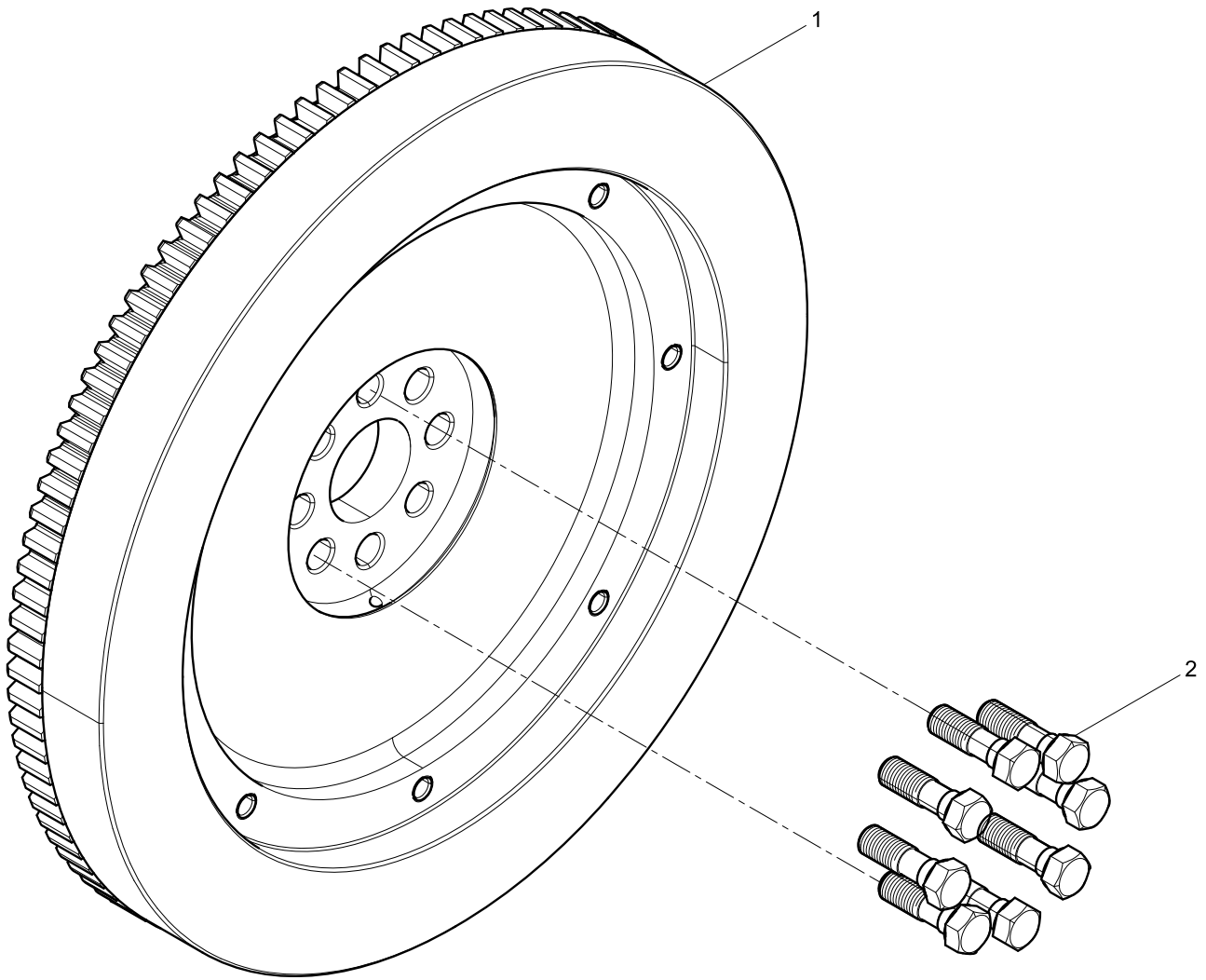

**飞轮结合组(Flywheel Group)**

图序号 Pos.	件号 Teile.Number	数量 Amount	中文名称 Denomination	英文名称 Designation
1	1001715429	1	飞轮总成	Flywheel Assembly
2	2040003	8	飞轮螺栓	Flywheel Bolt

# 飞轮总成(Flywheel Assembly)

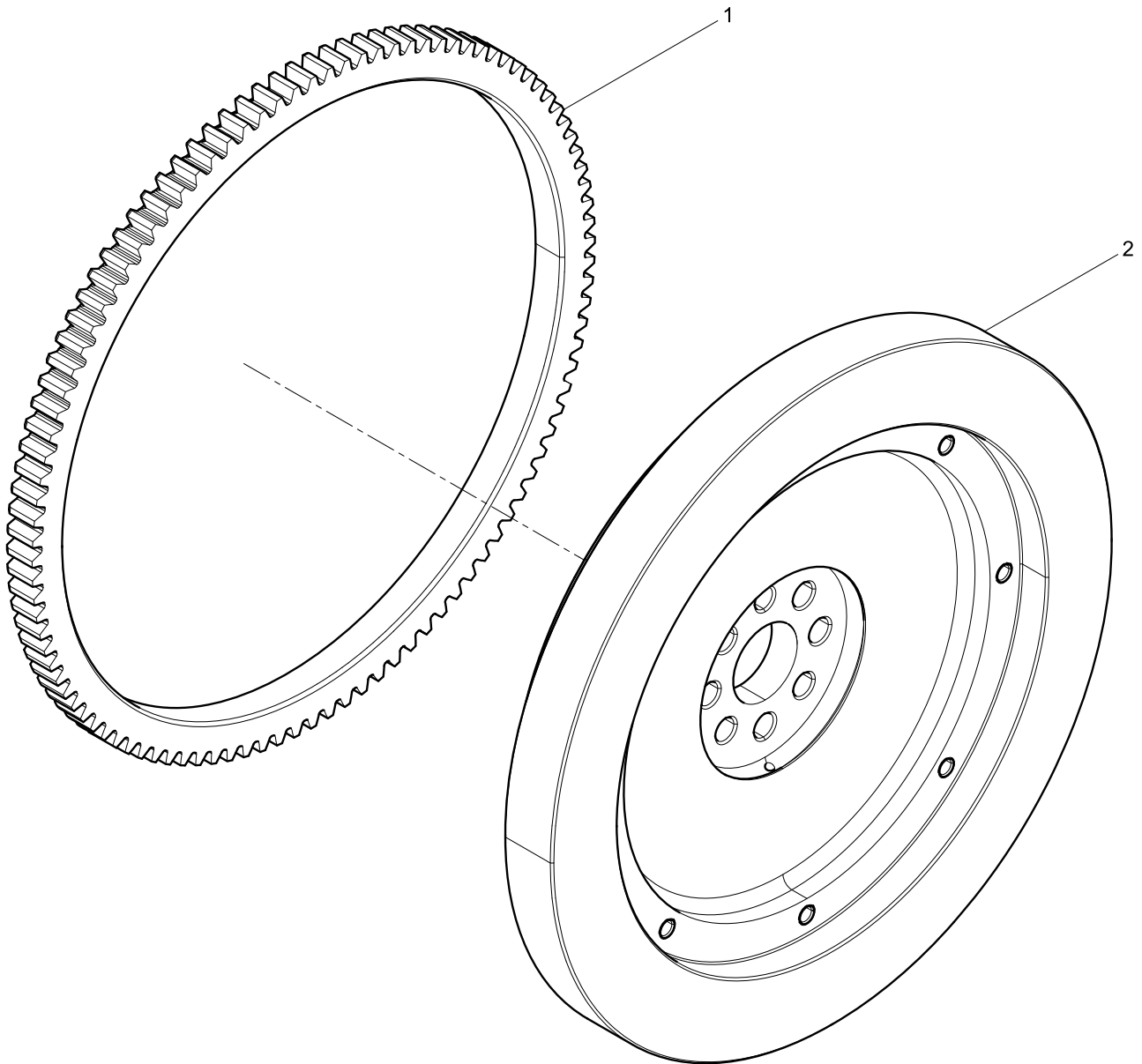



# 活塞连杆结合组(Piston and Connecting Rod Group)

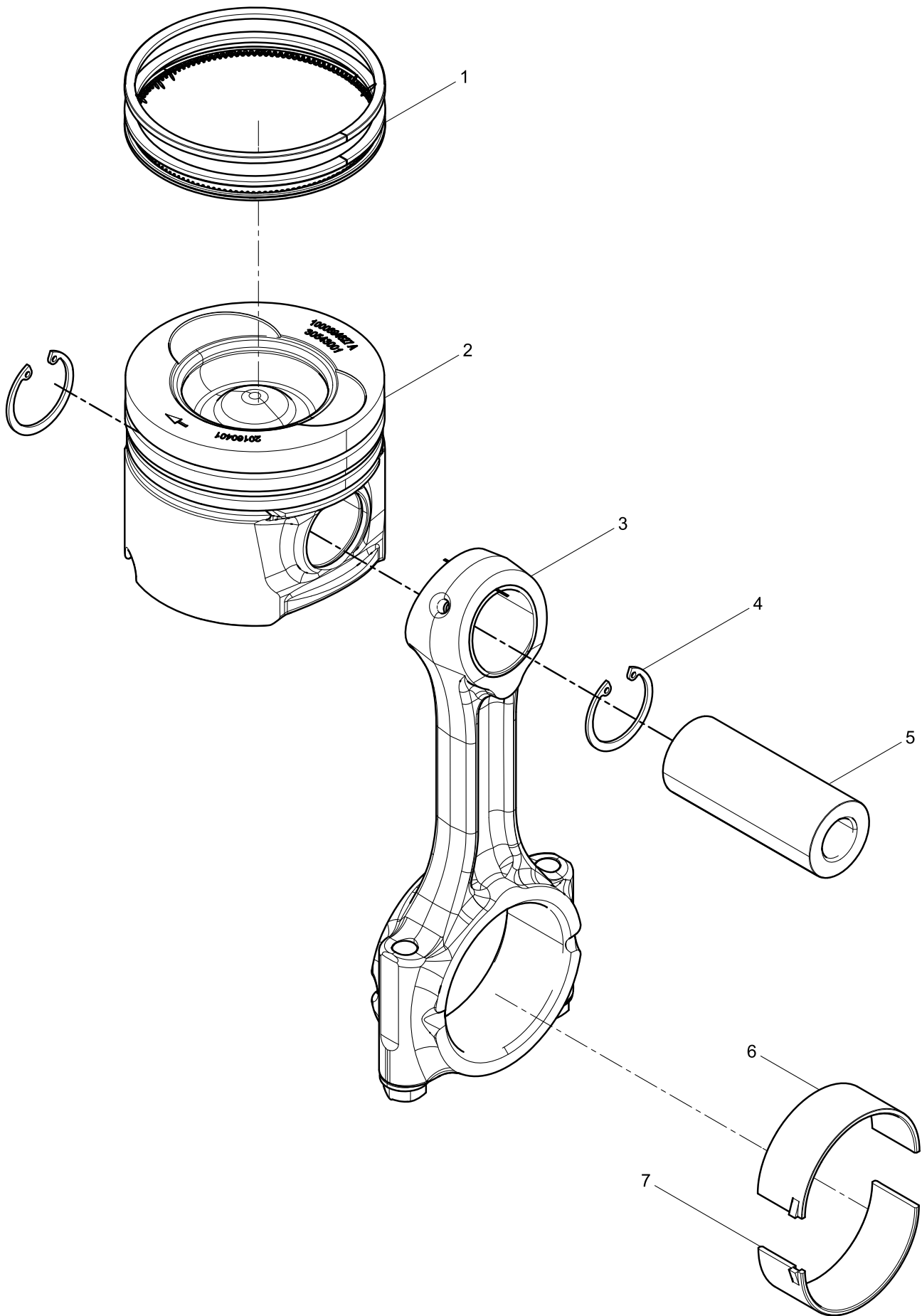

### 活塞连杆结合组(Piston and Connecting Rod Group)

图序号 Pos.	件号 Teile.Number	数量 Amount	中文名称 Denomination	英文名称 Designation
1	1000726572	1	活塞环组件	Piston Ring Set
2	1000694627	1	活塞	Piston
3	2085030136	1	连杆总成	Connecting Rod Assembly
4	2090030130	2	活塞销挡圈	Piston Pin Retainer
5	1000723096	1	活塞销	Piston Pin
6	1000709363	1	连杆上瓦	Connecting Rod Upper Shell
7	1000755580	1	连杆下瓦	Connecting Rod Lower Shell

# 活塞环组件(Piston Ring Set)

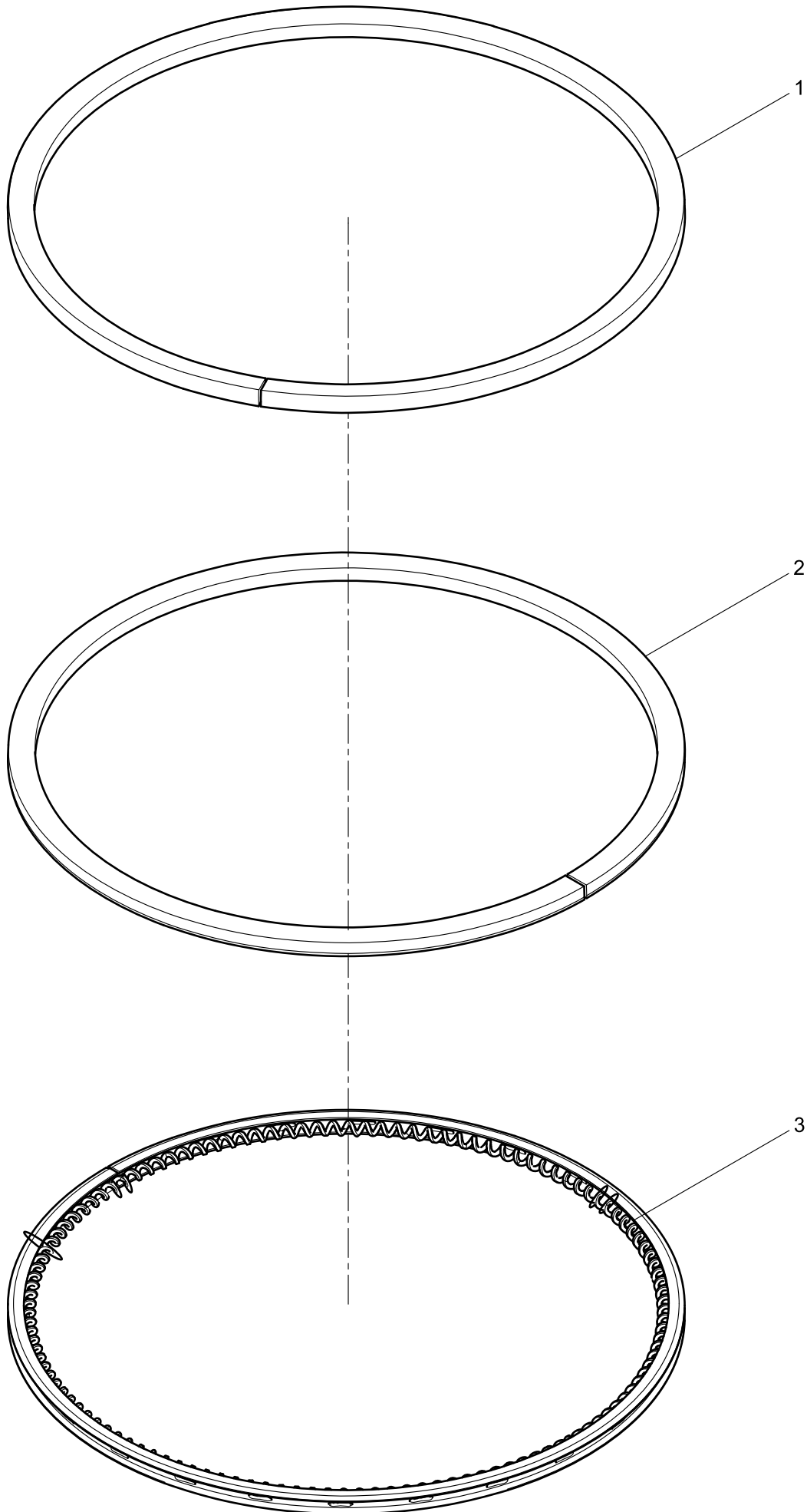

### 活塞环组件(Piston Ring Set)

图序号 Pos.	件号 Teile.Number	数量 Amount	中文名称 Denomination	英文名称 Designation
1	1000723326	1	梯形桶面环	Keystone Barrel Ring
2	1000723327	1	锥面环	Taper Ring
3	1000723382	1	螺旋撑簧油环	Coil Spring Loaded Oil-control Ring



# 连杆总成(Connecting Rod Assembly)

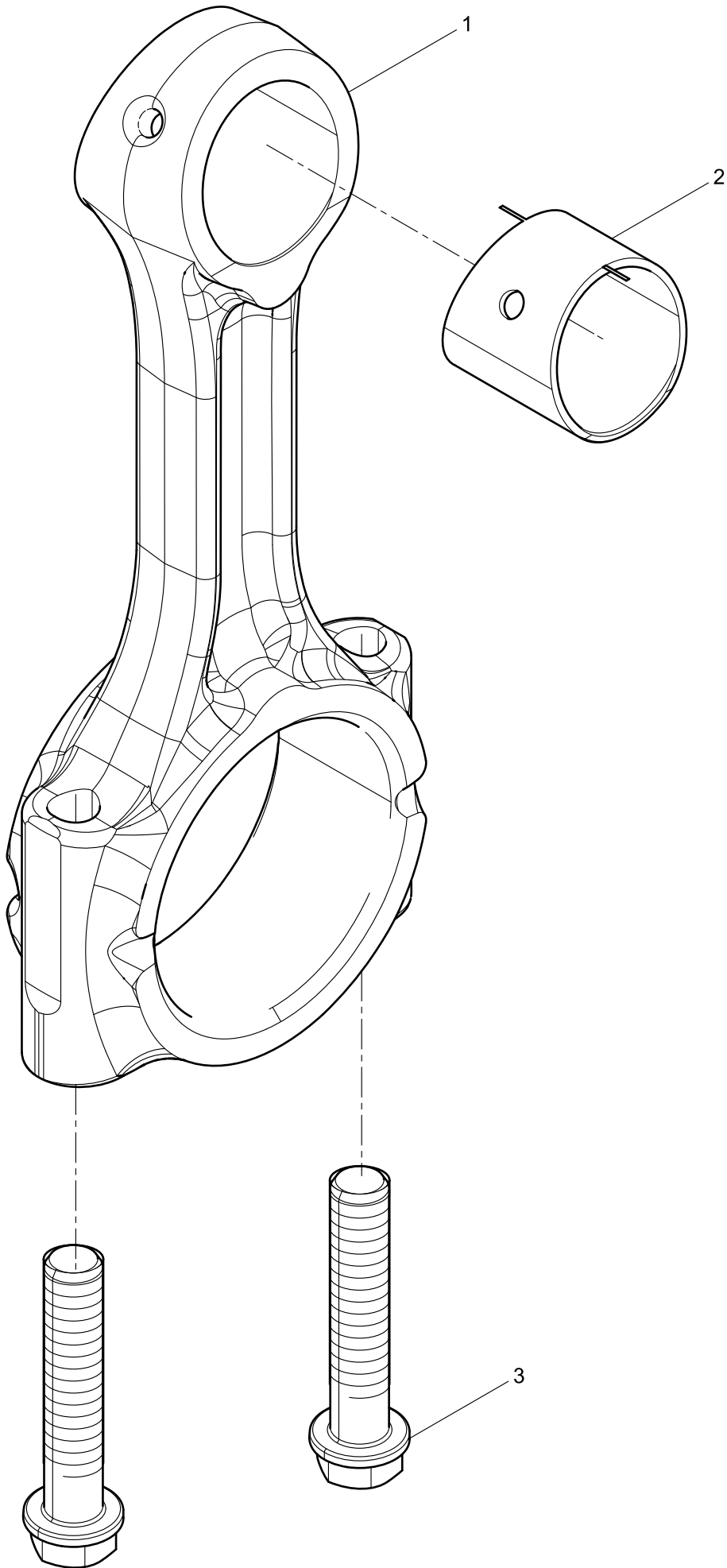



# 气缸盖结合组(Cylinder Head Group)

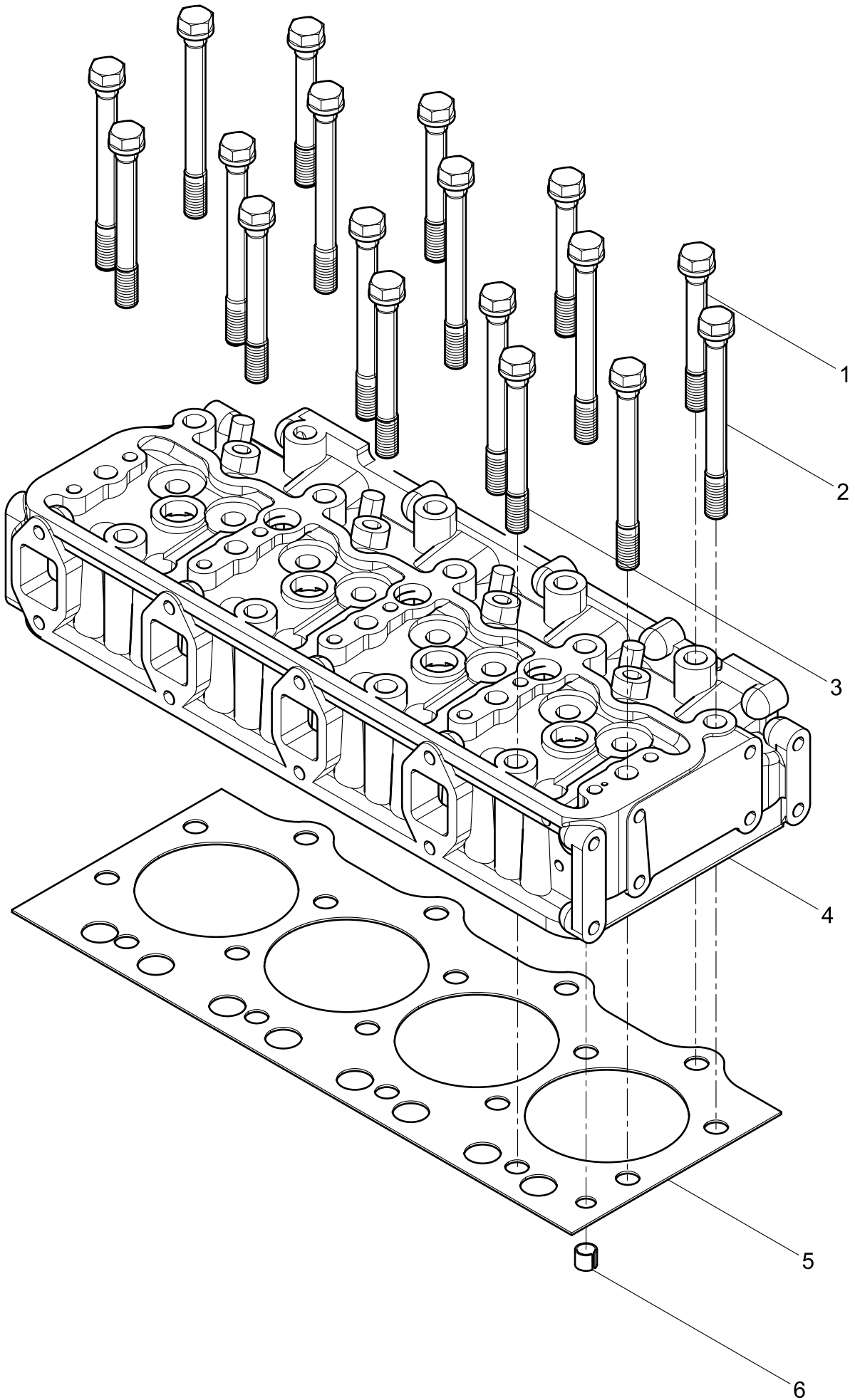

**气缸盖结合组(Cylinder Head Group)**

图序号 Pos.	件号 Teile.Number	数量 Amount	中文名称 Denomination	英文名称 Designation
1	2010008/1	4	气缸盖短螺栓	Cylinder head short bolt
2	2010010/1	10	气缸盖长螺栓	Cylinder head long bolt
3	2010005/1	4	气缸盖长螺栓	Cylinder head long bolt
4	2010391/2	1	气缸盖分总成	Cylinder Head Subassembly
5	1000612081	1	气缸盖垫片	Cylinder Head Gasket
6	2020106	1	定位套	Dowel Pin

# 气缸盖分总成(Cylinder Head Subassembly)

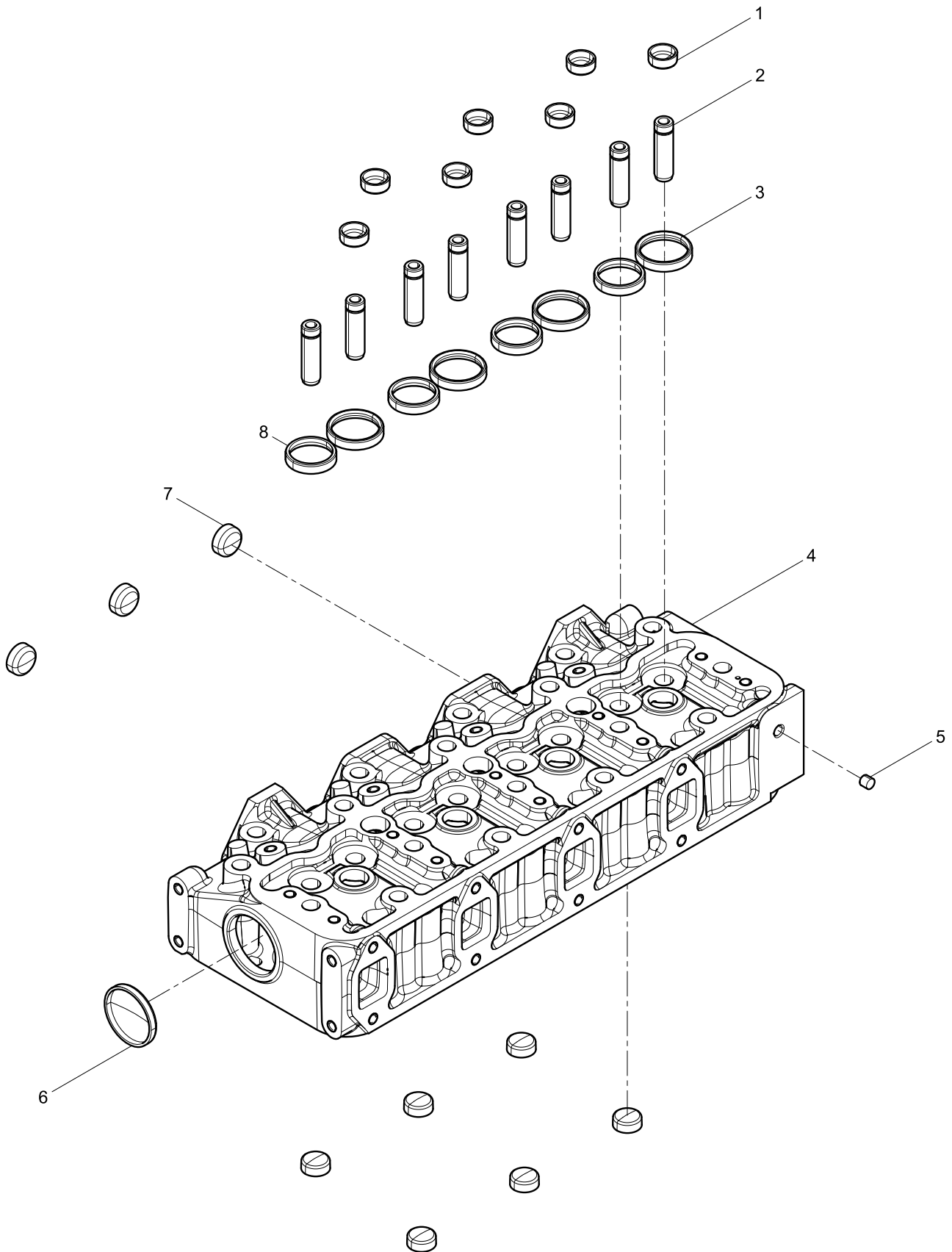



# 气缸盖前盖板结合组(Cylinder Head Front Cover Group)

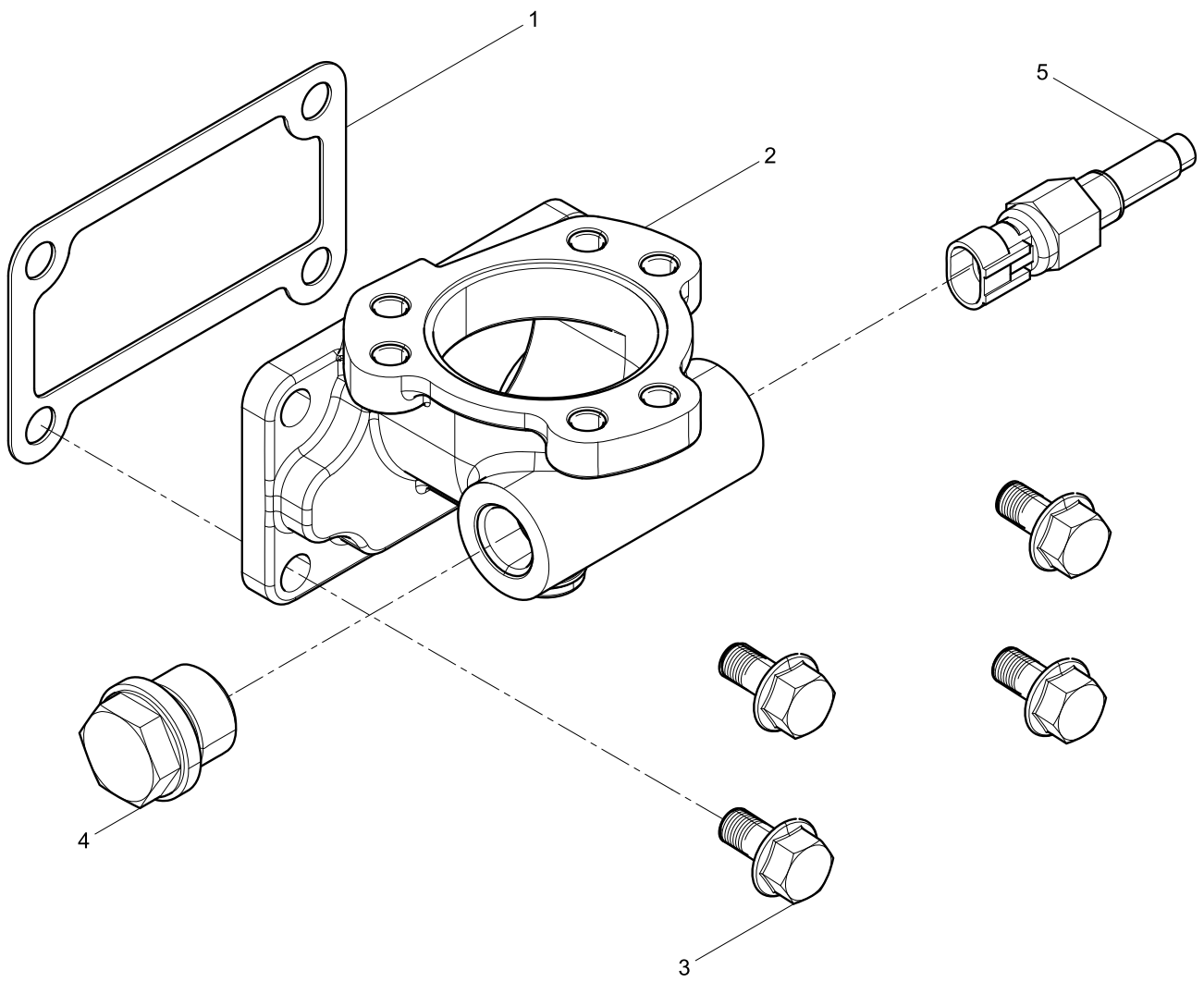

**气缸盖前盖板结合组(Cylinder Head Front Cover Group)**

图序号 Pos.	件号 Teile.Number	数量 Amount	中文名称 Denomination	英文名称 Designation
1	2010059	1	前盖板垫片	Front Cover Gasket
2	2014044	1	气缸盖前盖板	Cylinder Head Front Cover
3	90011400019	4	六角法兰面螺栓	Hexagon Flange Bolt
4	2NPT-3/8	1	螺塞	Screw Plug
5	612600090761	1	温度传感器	Temperature Sensor



吊环结合组(Eye Ring Group)

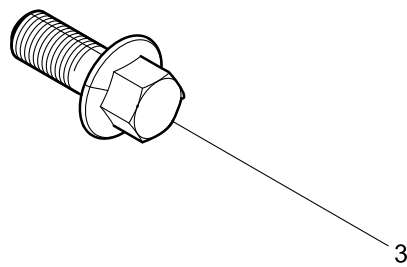
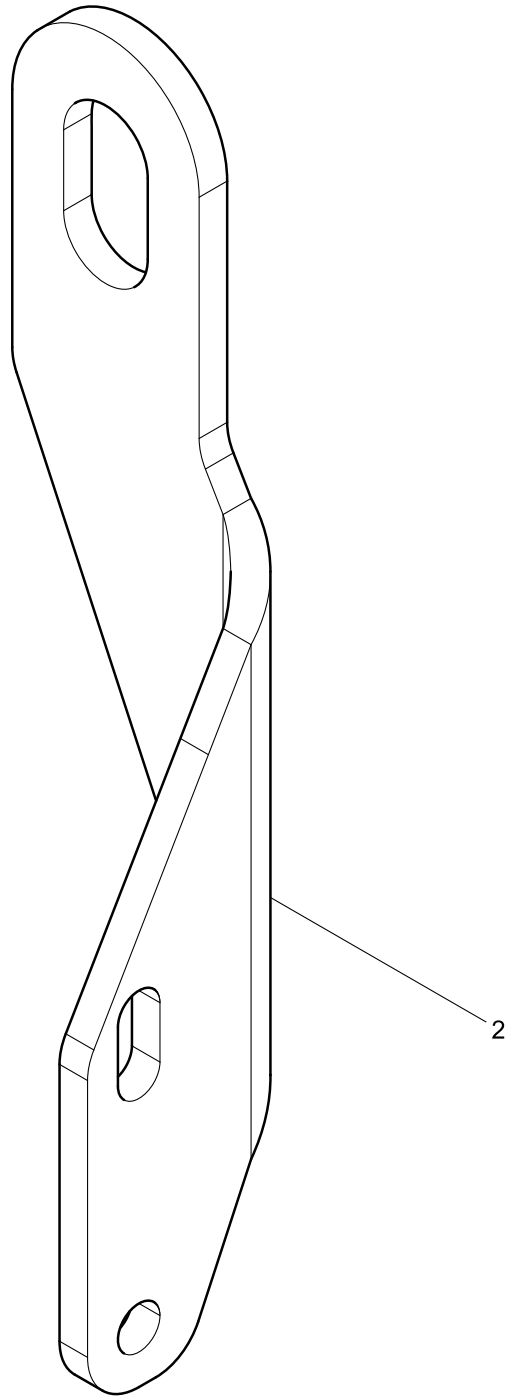
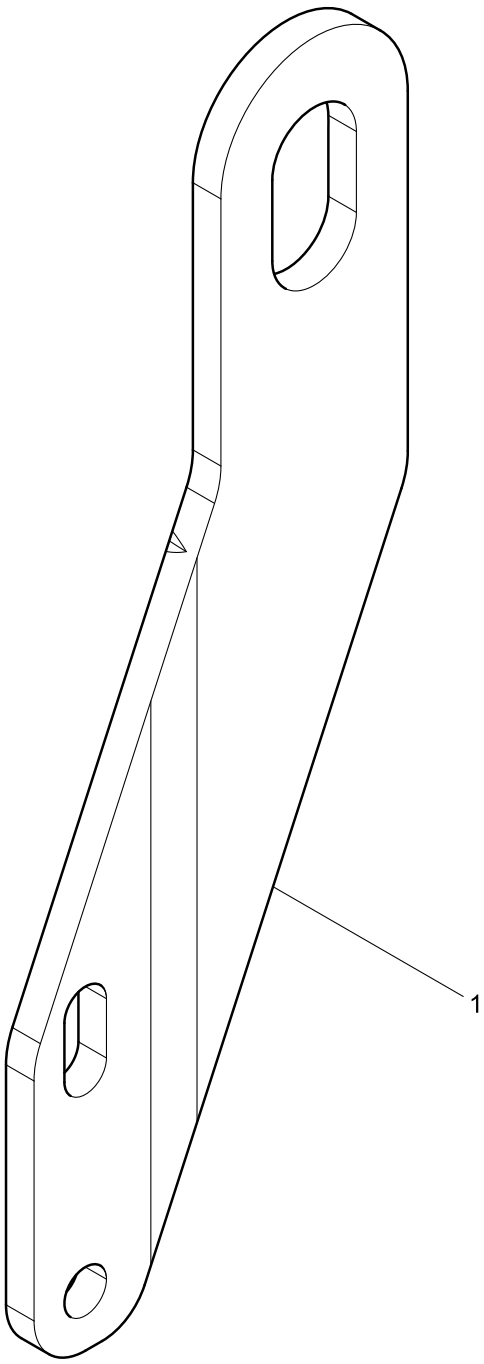



# 气缸盖罩结合组(Cylinder Head Cover Group)

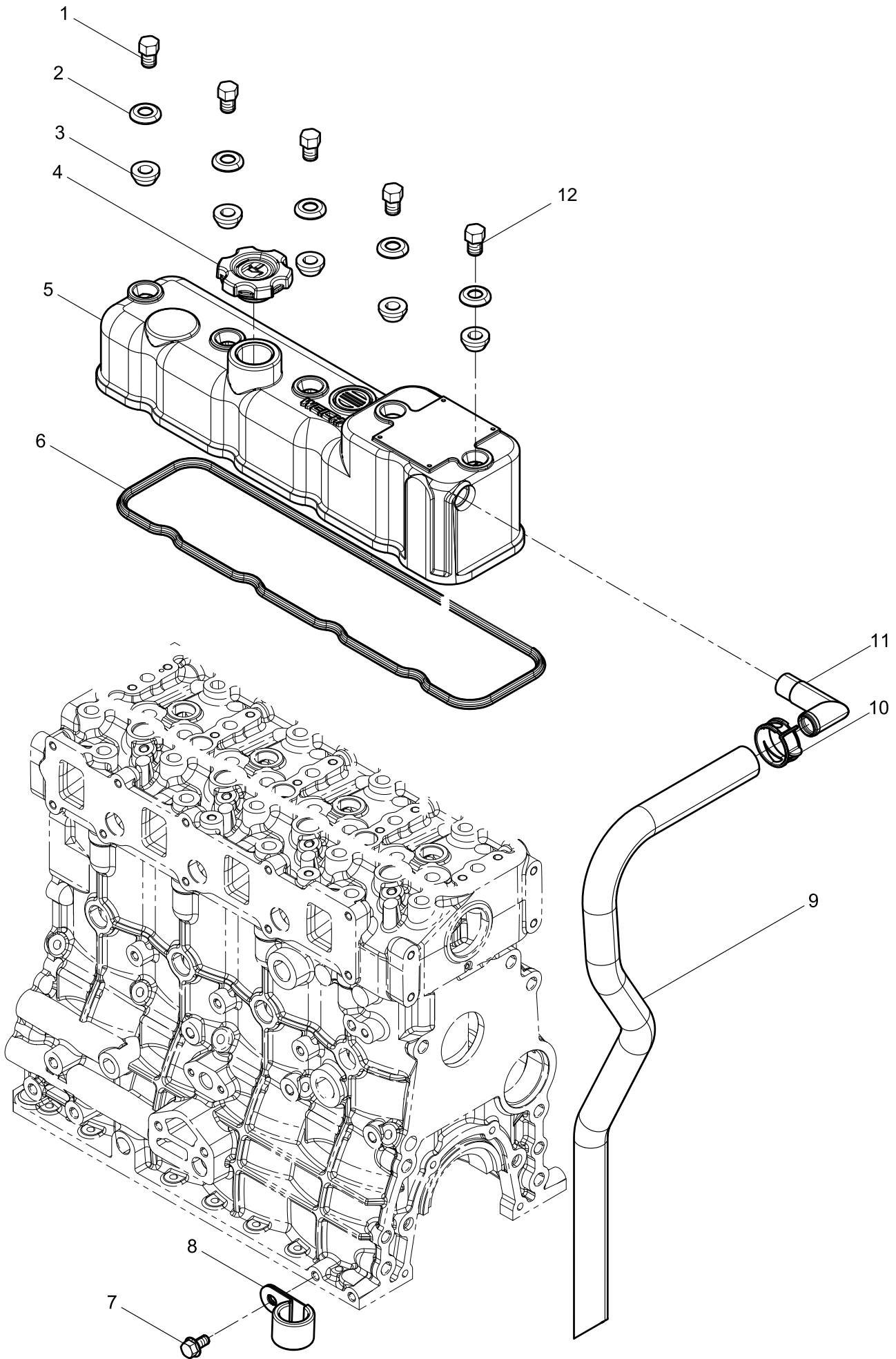



加机油口盖组件0

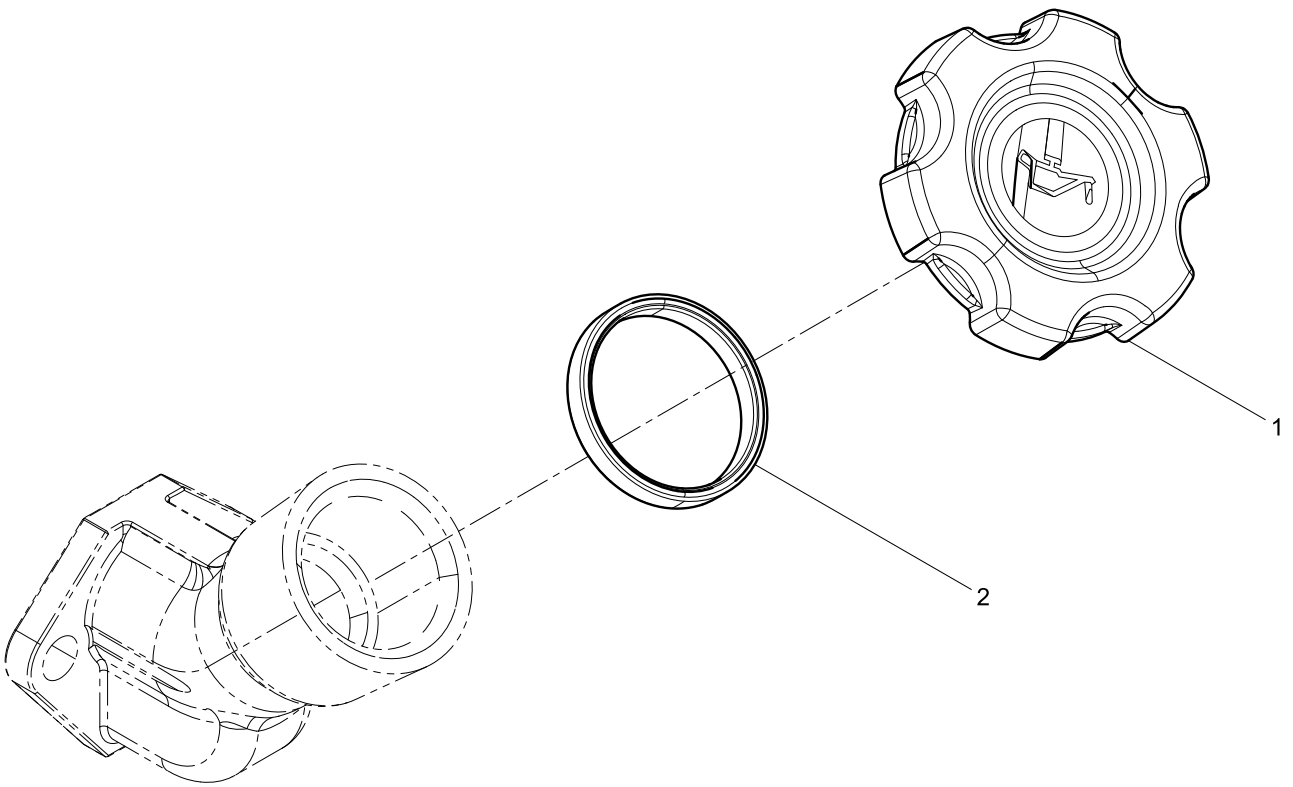



# 配气机构结合组(Valve Train Group)

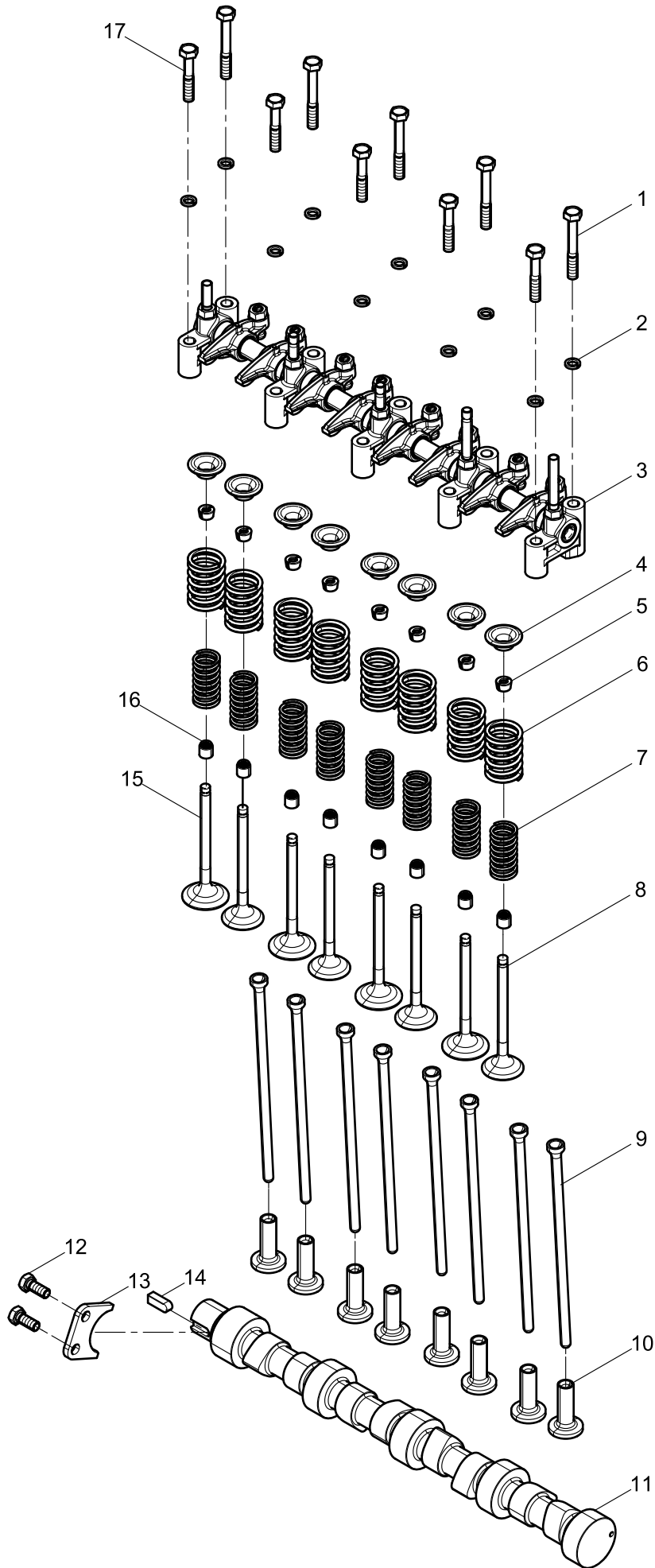

### 配气机构结合组(Valve Train Group)

图序号 Pos.	件号 Teile.Number	数量 Amount	中文名称 Denomination	英文名称 Designation
1	90011280014	5	六角头螺栓	Hexagon Head Bolt
2	90003931102	12	弹簧垫圈	Spring Washer
3	1000874515	1	整体式摇臂轴总成	Integrated Rocker Arm Shaft Assembly
4	2010111	8	气门弹簧上座	Valve Spring Top Retainer
5	2010063	8	锁夹	
6	2010056	8	气门外弹簧	Outer Valve Spring
7	2010053	8	气门内弹簧	Inner Valve Spring
8	1000803669	4	排气门	Exhaust Valve
9	2050206	8	推杆	Push Rod
10	2050327	8	挺柱	Tappet
11	2050361	1	凸轮轴	Camshaft
12	90003802419	2	六角头螺栓	Hexagon Head Bolt
13	2050102	1	凸轮轴止推片	Camshaft Thrust Plate
14	9000000051	1	普通平键	Square and Rectangular Key
15	2010382	4	进气门	Intake Valve
16	2010027	8	气门杆密封套	Valve Stem Seal
17	90011280007	5	六角头螺栓	Hexagon Head Bolt



# 整体式摇臂轴总成(Integrated Rocker Arm Shaft Assembly)

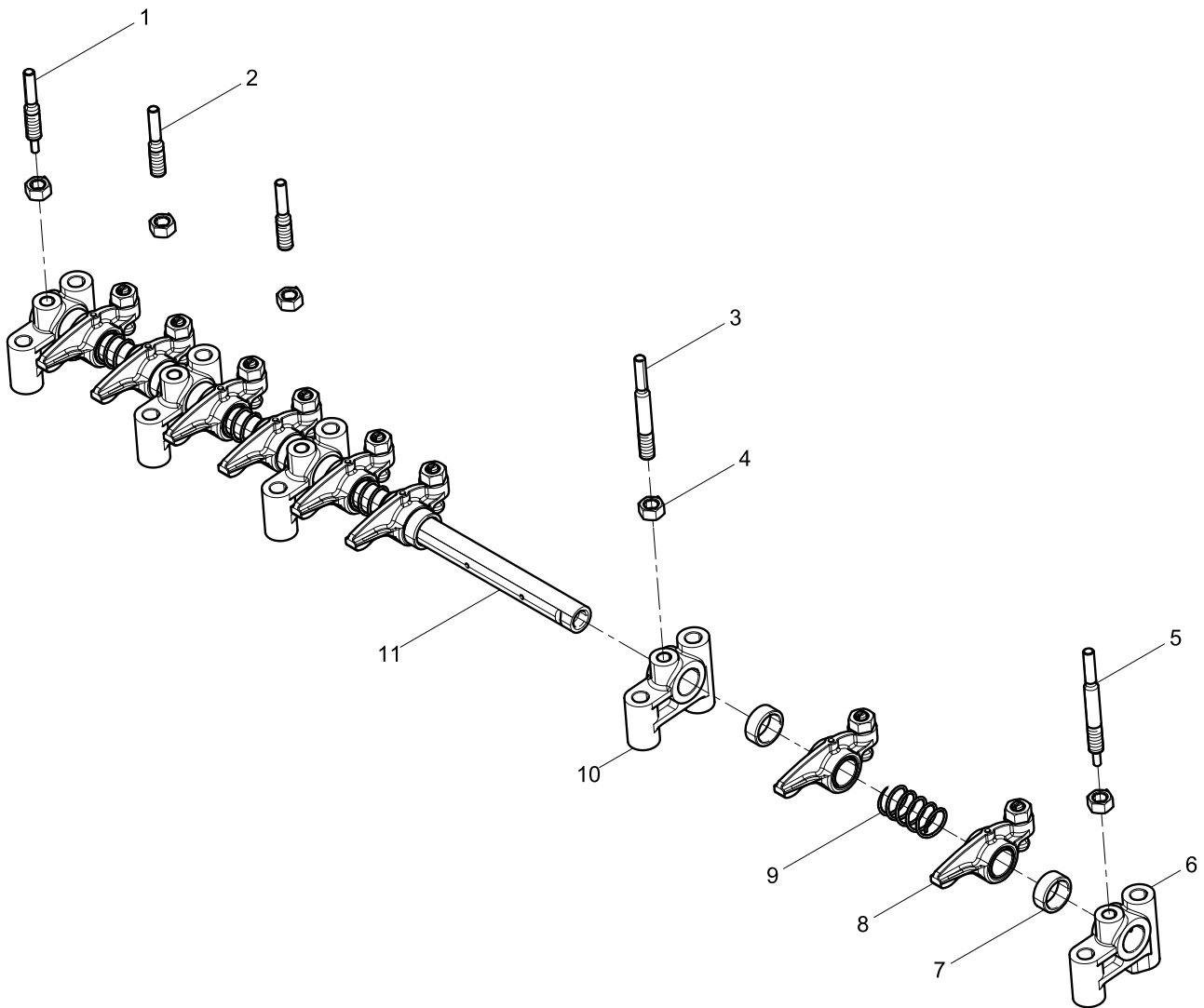

**整体式摇臂轴总成(Integrated Rocker Arm Shaft Assembly)**

图序号 Pos.	件号 Teile.Number	数量 Amount	中文名称 Denomination	英文名称 Designation
1	1000560296	1	螺栓	Bolt
2	1000560402	2	双头螺柱	Double End Stud
3	1000560619	1	双头螺柱	Double End Stud
4	90003871252	5	六角螺母	Hexagon Nut
5	1000561800	1	螺栓	Bolt
6	2010363	2	摇臂座	Rocker Arm Bracket
7	2010114	8	间隔套	Space Between Bushing
8	1000874519	8	摇臂组件	Rocker Arm Set
9	2010068	4	摇臂弹簧	Rocker Arm Spring
10	2010364	3	摇臂座	Rocker Arm Bracket
11	2010395/1	1	摇臂轴组件	Rocker Arm Shaft Set

# 齿轮传动结合组(Gear Drive Group)

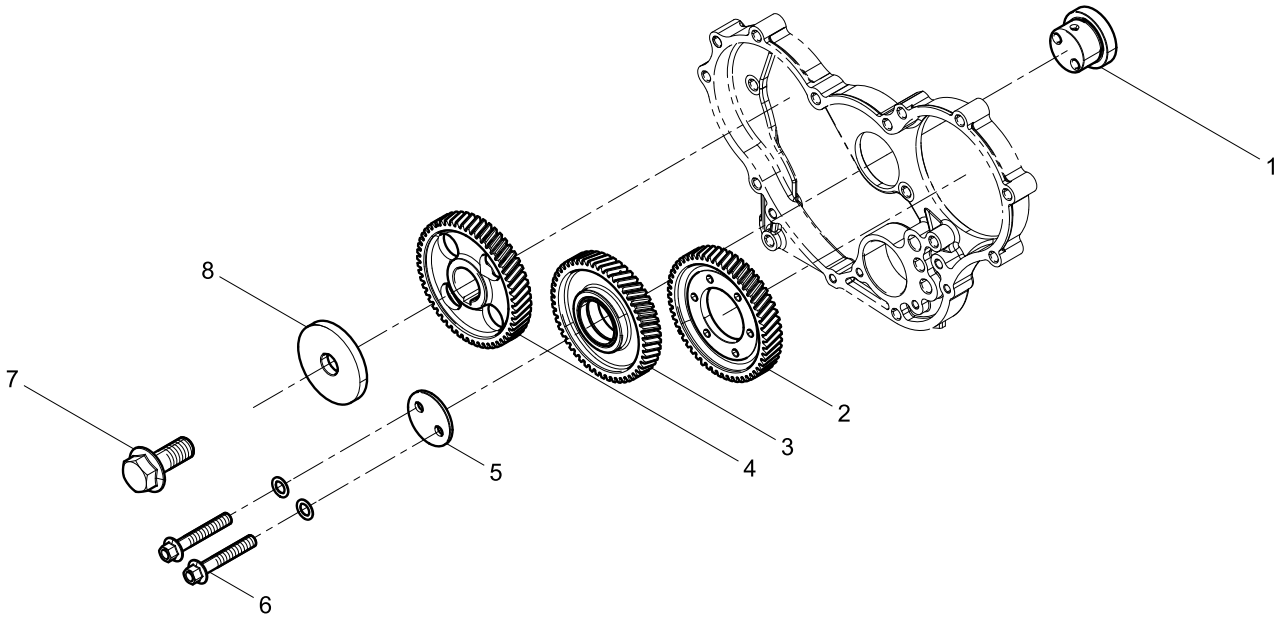

**齿轮传动结合组(Gear Drive Group)**

<b>图序号 Pos.</b>	<b>件号 Teile.Number</b>	<b>数量 Amount</b>	<b>中文名称 Denomination</b>	<b>英文名称 Designation</b>
1	2020101	1	中间齿轮轴	Idler Gear Shaft
2	2100101	1	喷油泵齿轮	Fuel Injection Pump Gear
3	2021888	1	中间齿轮总成	Idler Gear Assembly
4	2050209	1	凸轮轴正时齿轮	Camshaft Timing Gear
5	2020109	1	中间齿轮盖板	Middle Gear Cover
6	90011420024	2	六角法兰面螺栓	Hexagon Flange Bolt
7	2050118	1	盖板	Cover
8	90011400048	1	六角法兰面螺栓 加大系列	Hexagon flange bolt, heavy series

# 曲轴皮带轮结合组(Crankshaft Pulley Group)

2018/09/21 13:41:26

2018/09/21 13:41:26

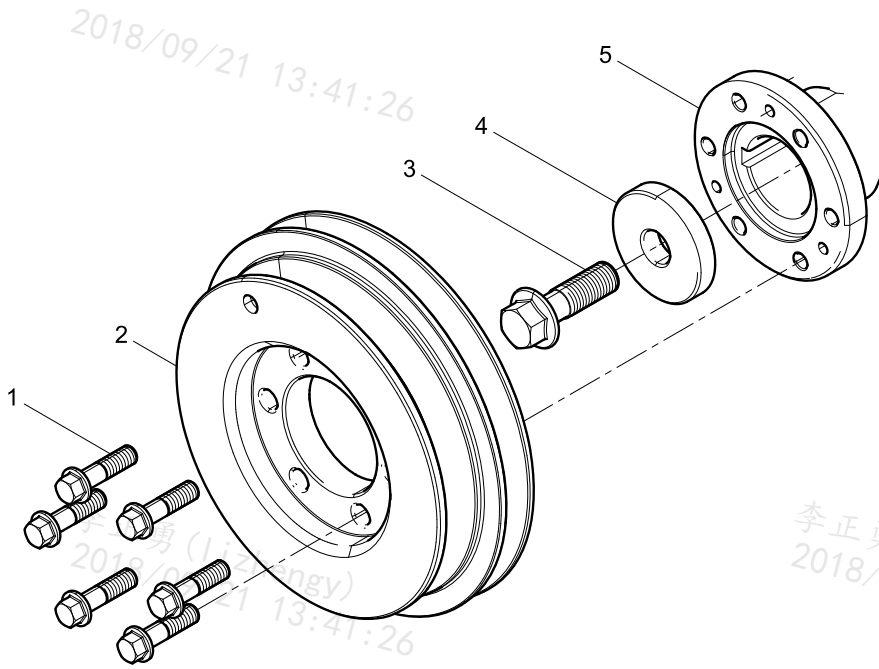

2018/09/21 13:41:26

李正勇(lizhengy)  
2018/09/21 13:41:26

李正勇(lizhengy)  
2018/09/21 13:41:26

李正勇(lizhengy)  
2018/09/21 13:41:26

李正勇(lizhengy)  
2018/09/21 13:41:26



# 油底壳结合组(Oil Pan Group)

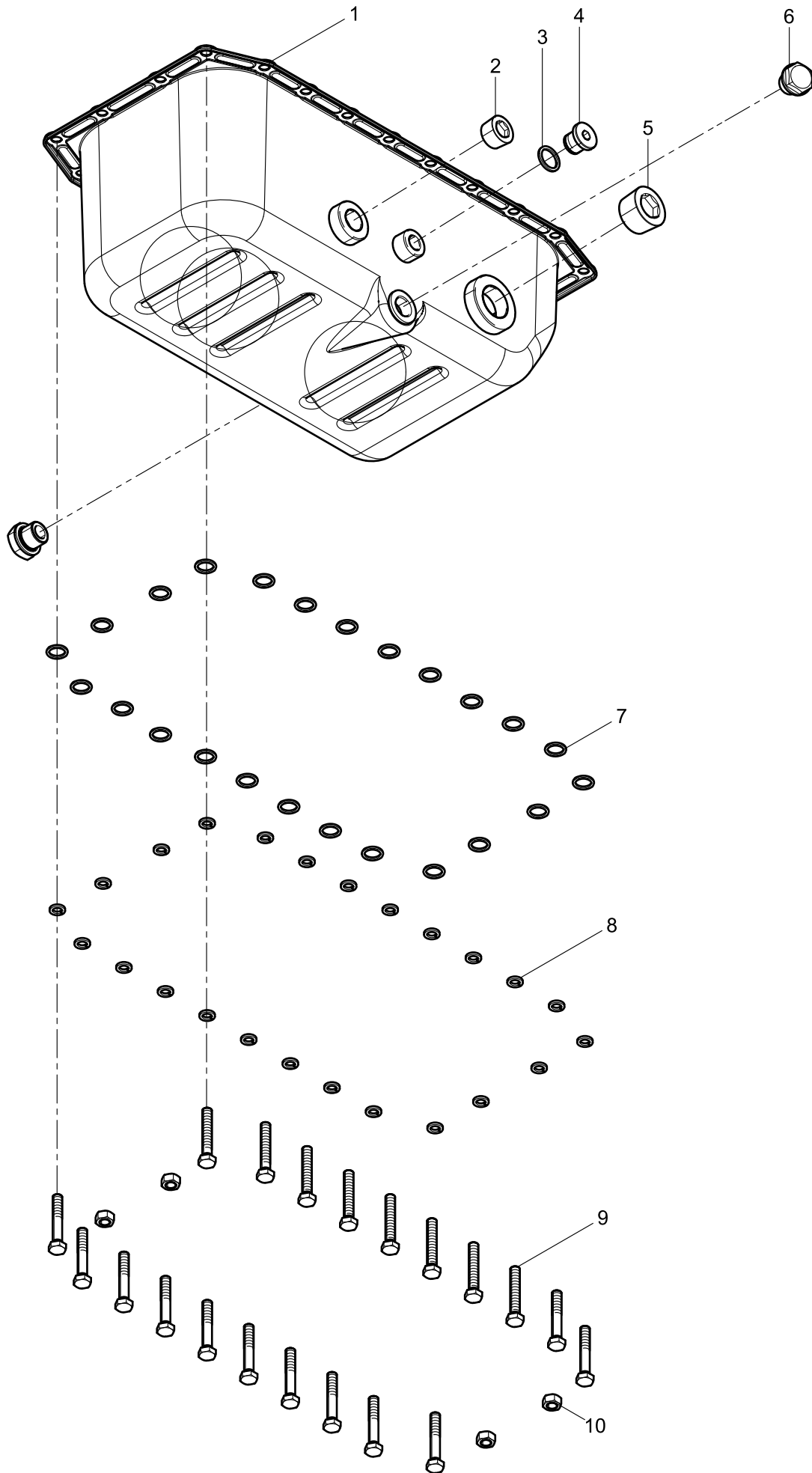

**油底壳结合组(Oil Pan Group)**

图序号 Pos.	件号 Teile.Number	数量 Amount	中文名称 Denomination	英文名称 Designation
1	1000668900	1	油底壳组件	Oil Pan Set
2	41770767A	1	内六角锥形螺塞	Inner hexagon srew plug
3	42020014A	1	垫圈	Washer
4	41772151F	1	内六角螺塞	Hexagon Taper Screw Plug
5	41770758A	1	内六角锥形螺塞	Inner hexagon srew plug
6	1001230616	2	放油螺塞	Oil Drain Plug
7	90014040019	24	平垫圈 A级	Plain washer
8	90003931102	24	弹簧垫圈	Spring Washer
9	90003802419	20	六角头螺栓	Hexagon Head Bolt
10	90003871252	4	1型六角螺母	Hexagon Nuts, Style 1



放油螺塞(Oil Drain Plug)

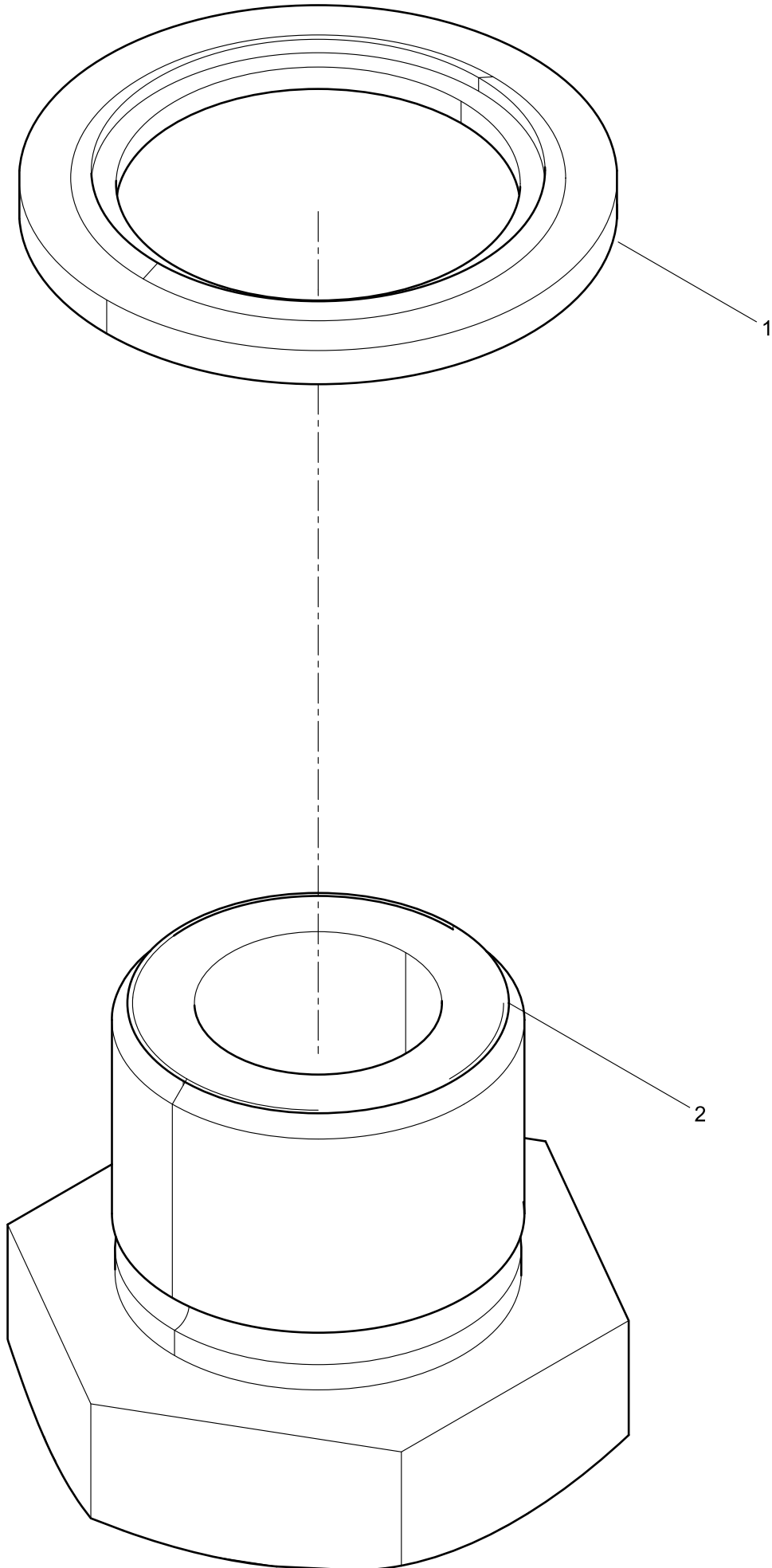

放油螺塞(Oil Drain Plug)

图序号 Pos.	件号 Teile.Number	数量 Amount	中文名称 Denomination	英文名称 Designation
1	13023363	1	组合密封垫圈	Assembled Sealing Washer
2	1000650859	1	放油螺塞	Oil Drain Plug

# 油标尺结合组(Oil Dipstick Group)

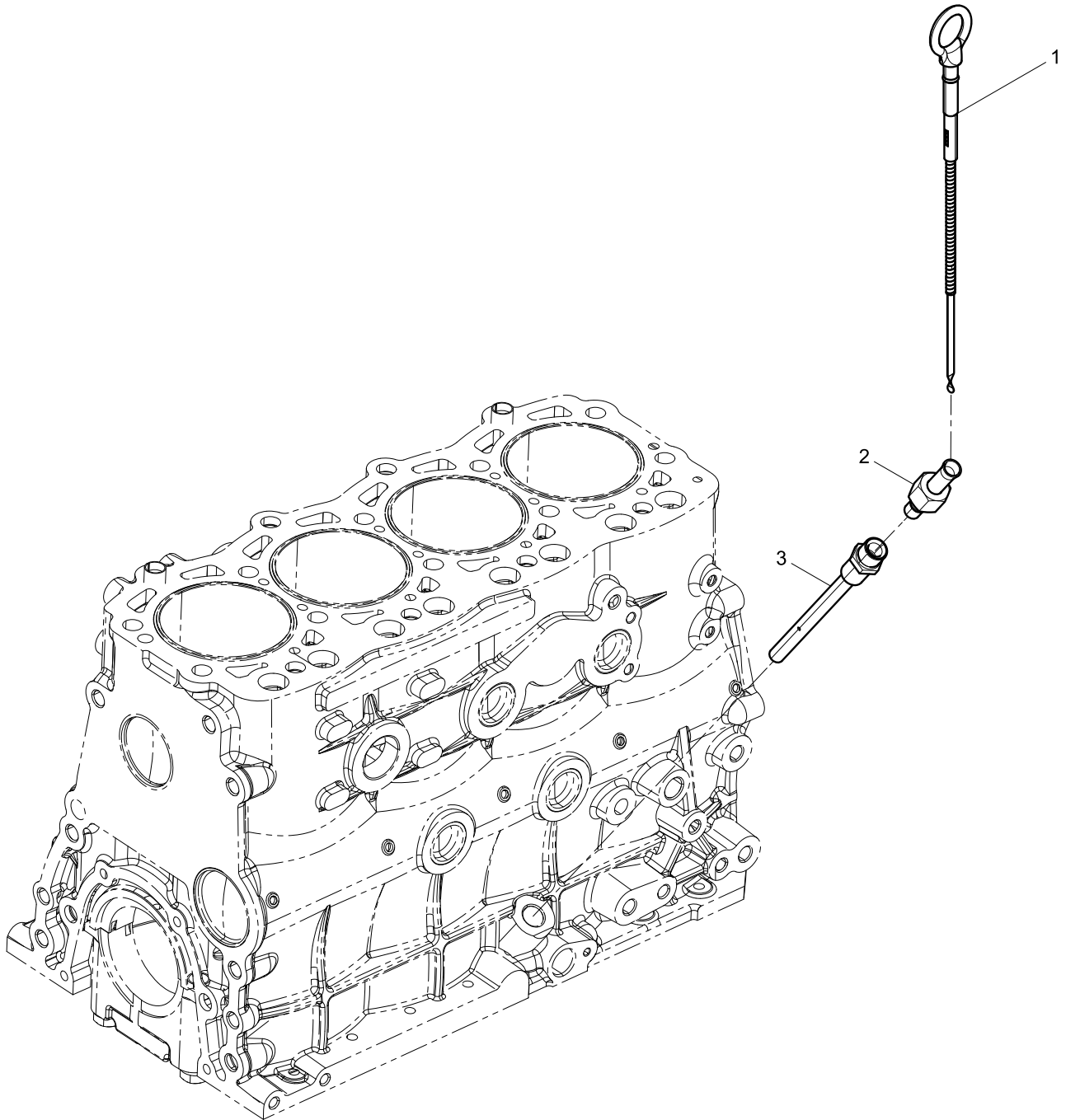



# 机油泵结合组(Oil Pump Group)

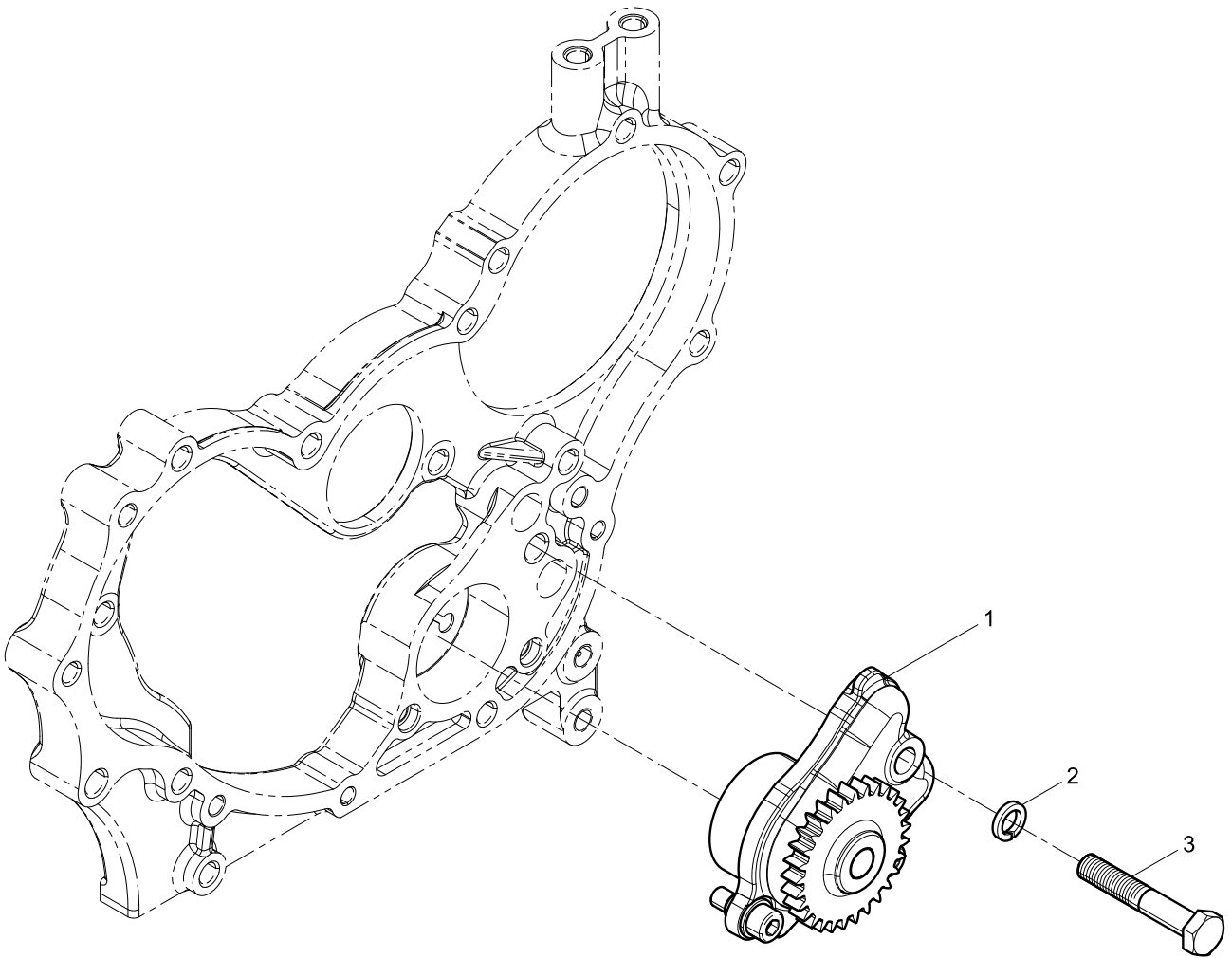

**机油泵结合组(Oil Pump Group)**

图序号 Pos.	件号 Teile.Number	数量 Amount	中文名称 Denomination	英文名称 Designation
1	1000497382	1	机油泵	Lubricating Oil Pump
2	90003931122	1	弹簧垫圈	Spring Washer
3	90011350033	1	六角头螺栓	Hexagon Head Bolt

# 机油集滤器结合组(Oil Strainer Group)

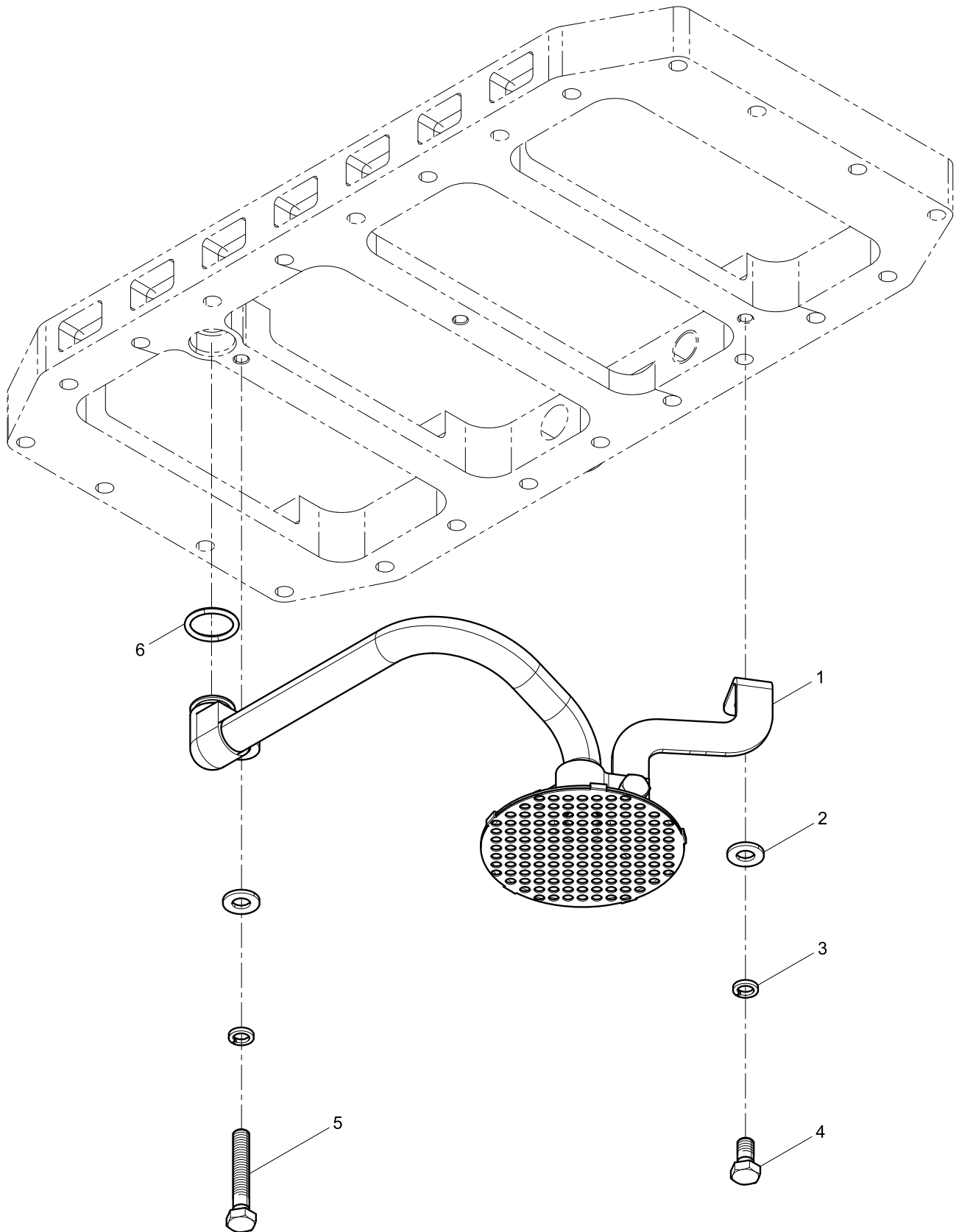





# 机油滤清器结合组(Oil Filter Group)

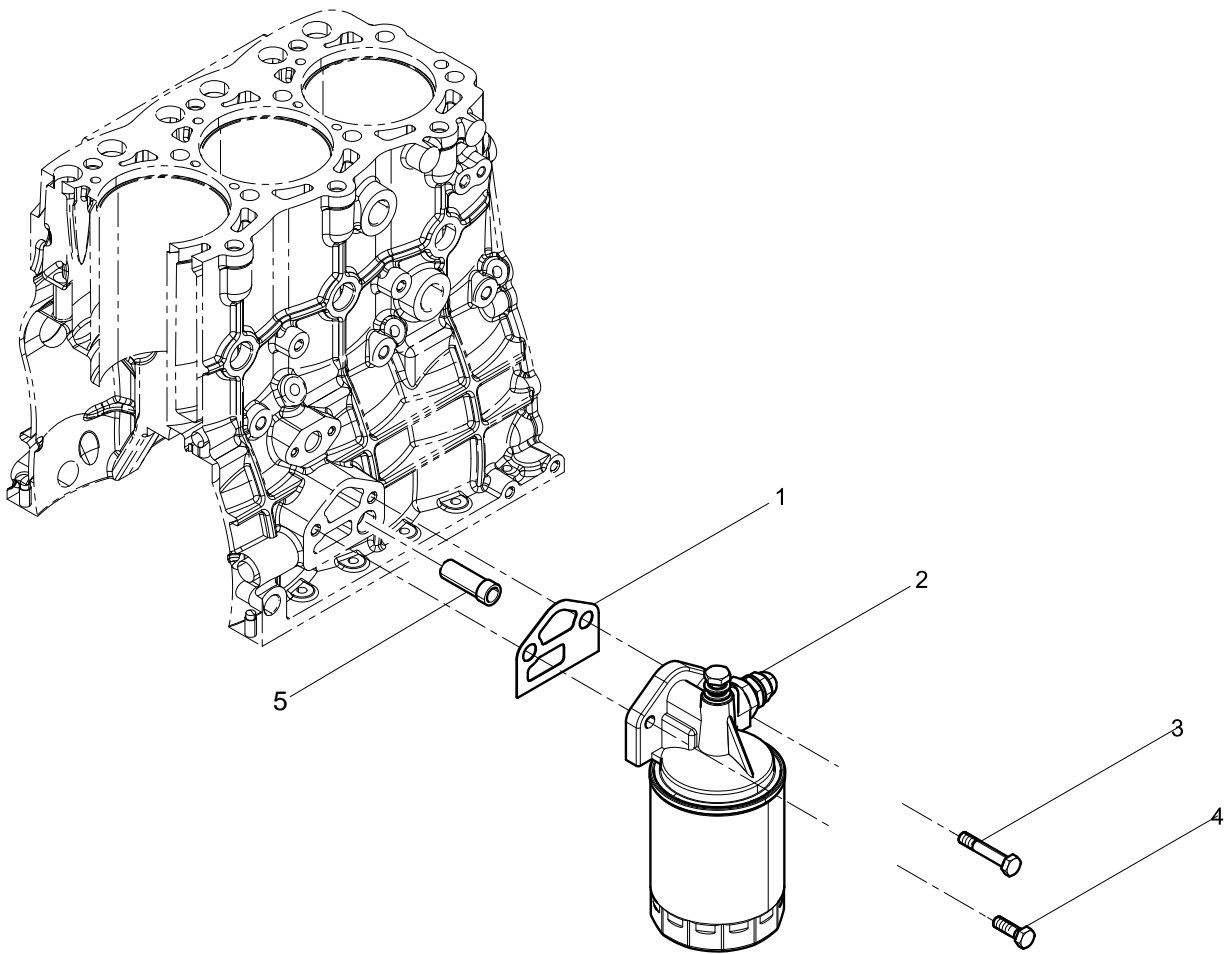

**机油滤清器结合组(Oil Filter Group)**

图序号 Pos.	件号 Teile.Number	数量 Amount	中文名称 Denomination	英文名称 Designation
1	2170110	1	机滤座垫片	Oil Filter Seat Gasket
2	1001909731	1	机油滤清器	Oil Filter
	1001910416	1	机油滤清器滤芯	Oil Filter Element
	1001928050	1	机油滤清器座组件	Oil Filter Seat Set
3	9000000093	1	六角法兰面螺栓	Hexagon Flange Bolt
4	9000000092	1	六角法兰面螺栓	Hexagon Flange Bolt
5	2170100	1	油管接头	

# 水泵结合组(Water Pump Group)

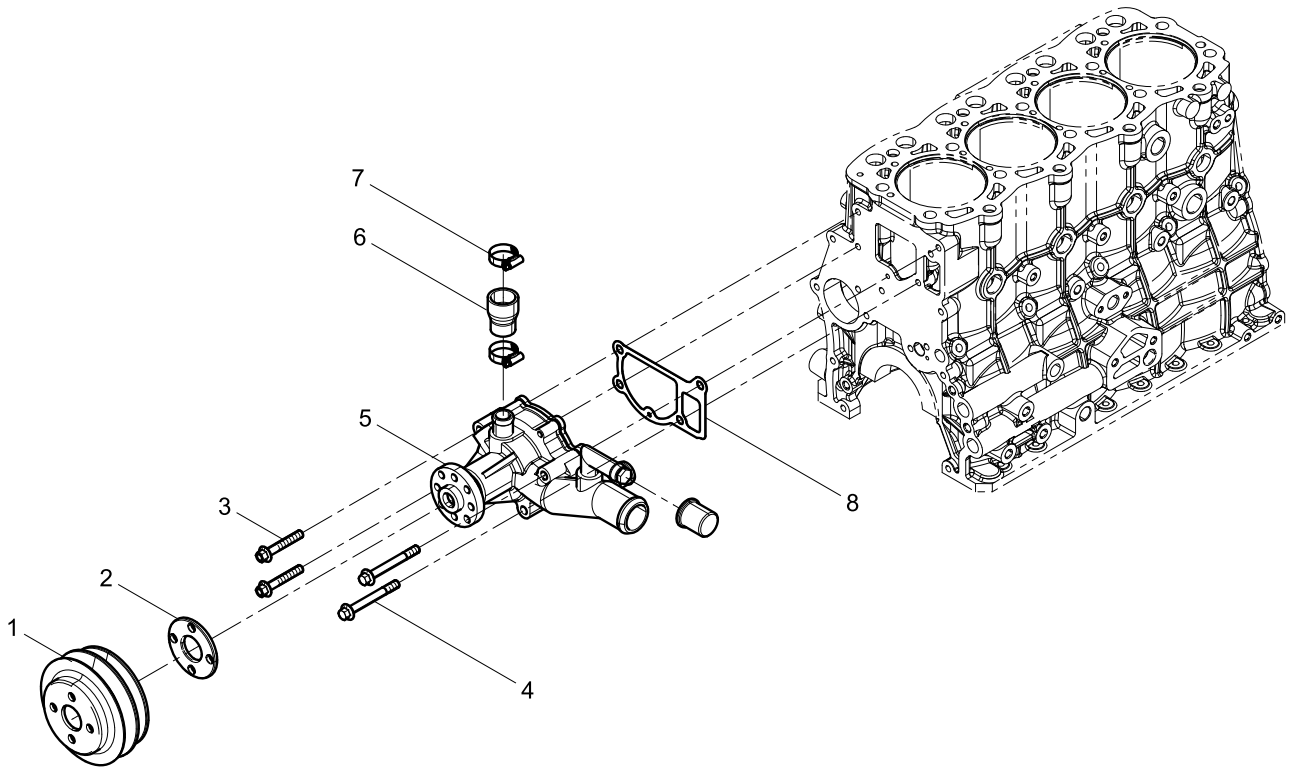

**水泵结合组(Water Pump Group)**

图序号 Pos.	件号 Teile.Number	数量 Amount	中文名称 Denomination	英文名称 Designation
1	1000386535	1	水泵皮带轮	Water Pump Pulley
2	2085060001	1	水泵中间垫块	Water Pump Middle Filling Block
3	90011420024	2	六角法兰面螺栓	Hexagon Flange Bolt
4	90011410008	1	六角法兰面螺栓	Hexagon Flange Bolt
5	2190252/2	1	水泵	Water Pump
6	2010412	1	冷却液连接胶管	Coolant Connecting Rubber Pipe
7	2190444	2	喉箍	Clip
8	1000795642	1	水泵密封垫	Water Pump Sealing Gasket

# 节温器结合组(Thermostat Group)

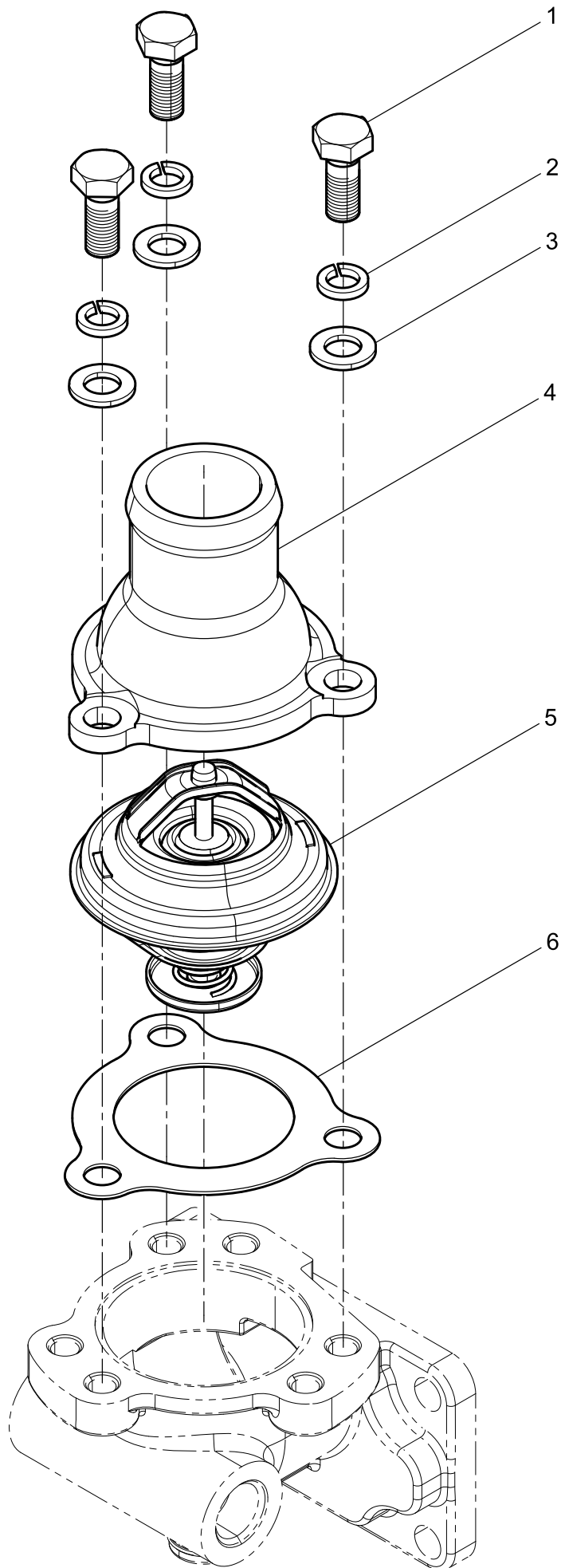

节温器结合组(Thermostat Group)

图序号 Pos.	件号 Teile.Number	数量 Amount	中文名称 Denomination	英文名称 Designation
1	2BLS-M8X20/8.8	3	六角螺栓	Hexagon head bolt
2	2BTDQ-D8	3	弹簧垫圈	Spring Washer
3	2BPDQ-D8	3	平垫圈	Plain Washer
4	2014407	1	节温器盖	Thermostat Cover
5	21033-72-K/155B	1	节温器	Thermostat
6	2010017	1	节温器盖垫片	gasket

# 散热器结合组(Radiator Group)

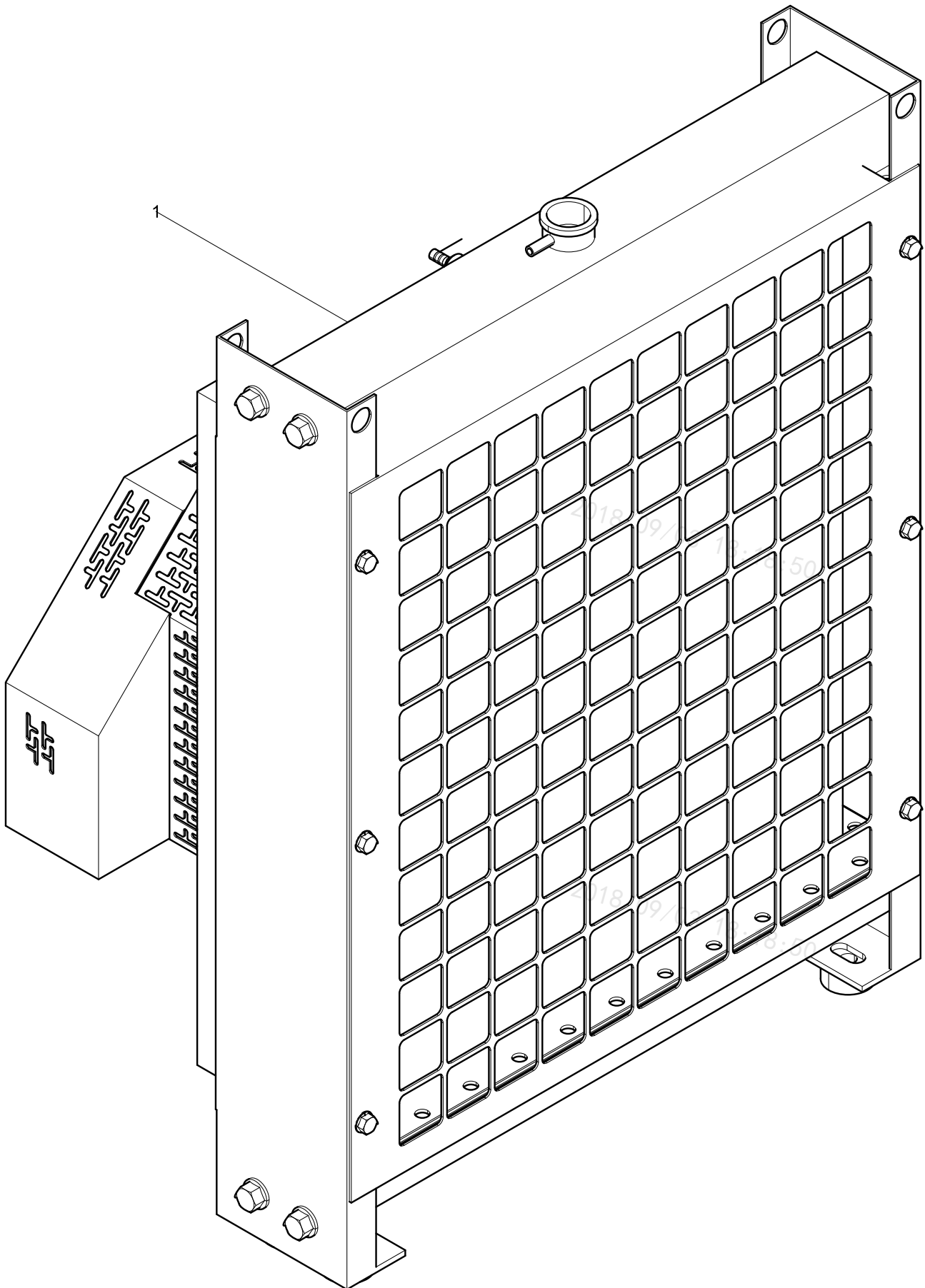

**散热器结合组(Radiator Group)**

<b>图序号 Pos.</b>	<b>件号 Teile.Number</b>	<b>数量 Amount</b>	<b>中文名称 Denomination</b>	<b>英文名称 Designation</b>
1	1001603577	1	散热器	Radiator



风扇及轮毂结合组(Fan and Hub Group)

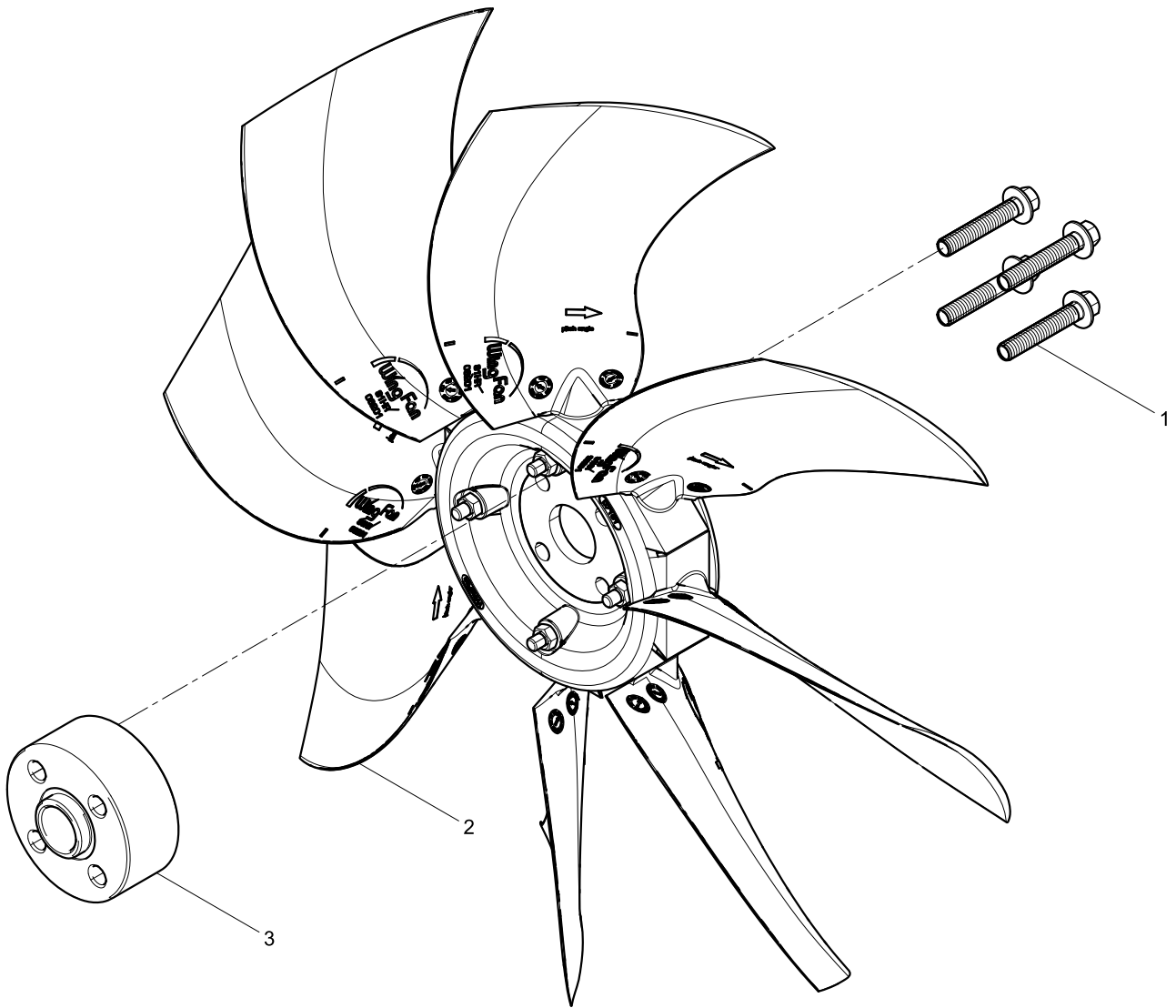

风扇及轮毂结合组(Fan and Hub Group)

图序号 Pos.	件号 Teile.Number	数量 Amount	中文名称 Denomination	英文名称 Designation
1	9000000324	4	六角法兰面螺栓	Hexagon Flange Bolt
2	2210034	1	塑料风扇	
3	1000971194	1	风扇连接盘	Fan Flange

# 喷油泵结合组(Fuel Injection Pump Group)

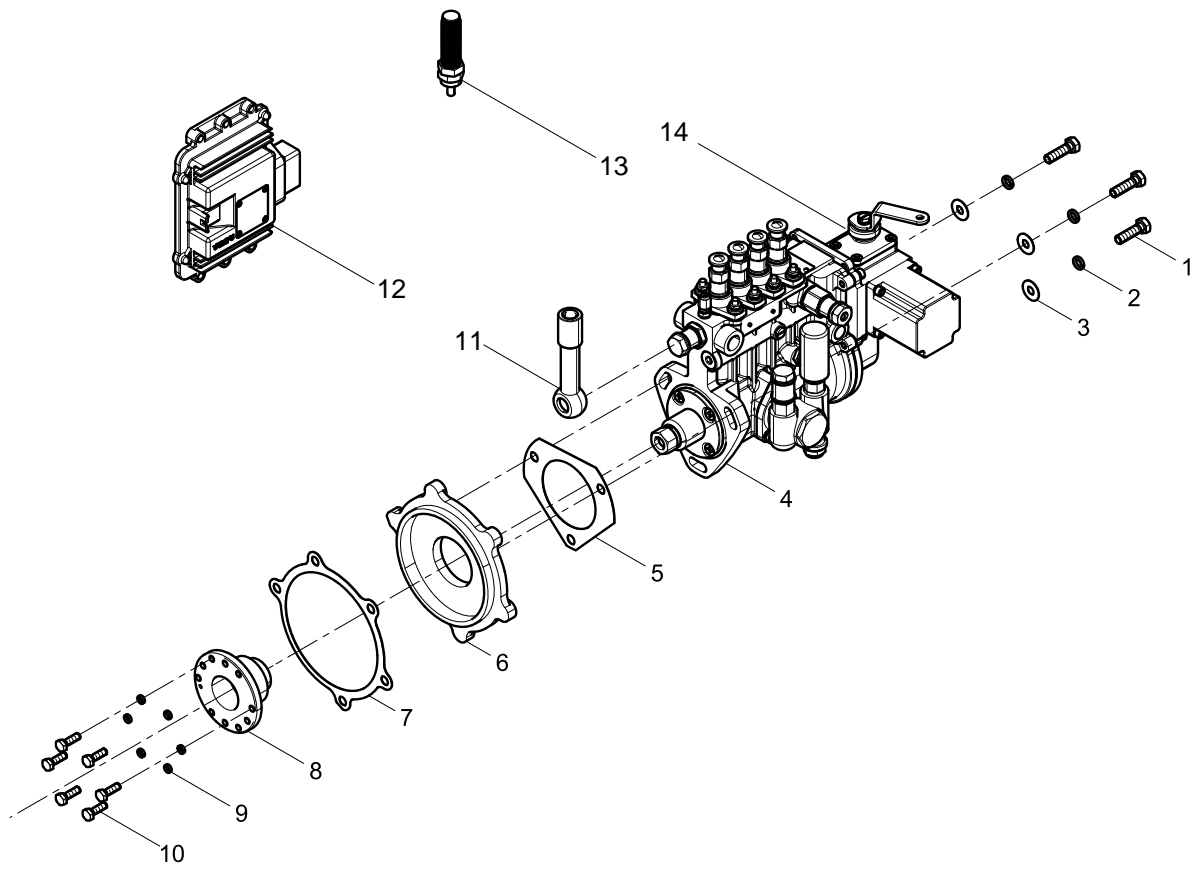

**喷油泵结合组(Fuel Injection Pump Group)**

图序号 Pos.	件号 Teile.Number	数量 Amount	中文名称 Denomination	英文名称 Designation
1	90003802432	3	六角头螺栓	Hexagon Head Bolt
2	90003931102	3	弹簧垫圈	Spring Washer
3	90014040007	3	平垫圈	Plain Washer
4	1000374710	1	喷油泵体	Fuel Injection Pump Housing
5	2100003	1	垫片	Gasket
6	1001309072	1	喷油泵法兰总成	Fuel Injection Pump Flange Assembly
7	90017510078	1	O形橡胶密封圈	O-ring
8	1000623588	1	联接盘	Connecting Plate
9	90014350003	6	弹簧垫圈	Spring Washer
10	90003802331	6	六角头螺栓	Hexagon Head Bolt
11	2120697	1	油泵排气接头	Pipe joint
12	1001668808	1	转速控制器	Speed Controller
13	1001668438	1	转速传感器	Speed Sensor
14	1000366889	1	电磁执行器	Electromagnetic Actuator

喷油泵润滑油管结合组(Fuel Injection Pump Oil Pipe Group)

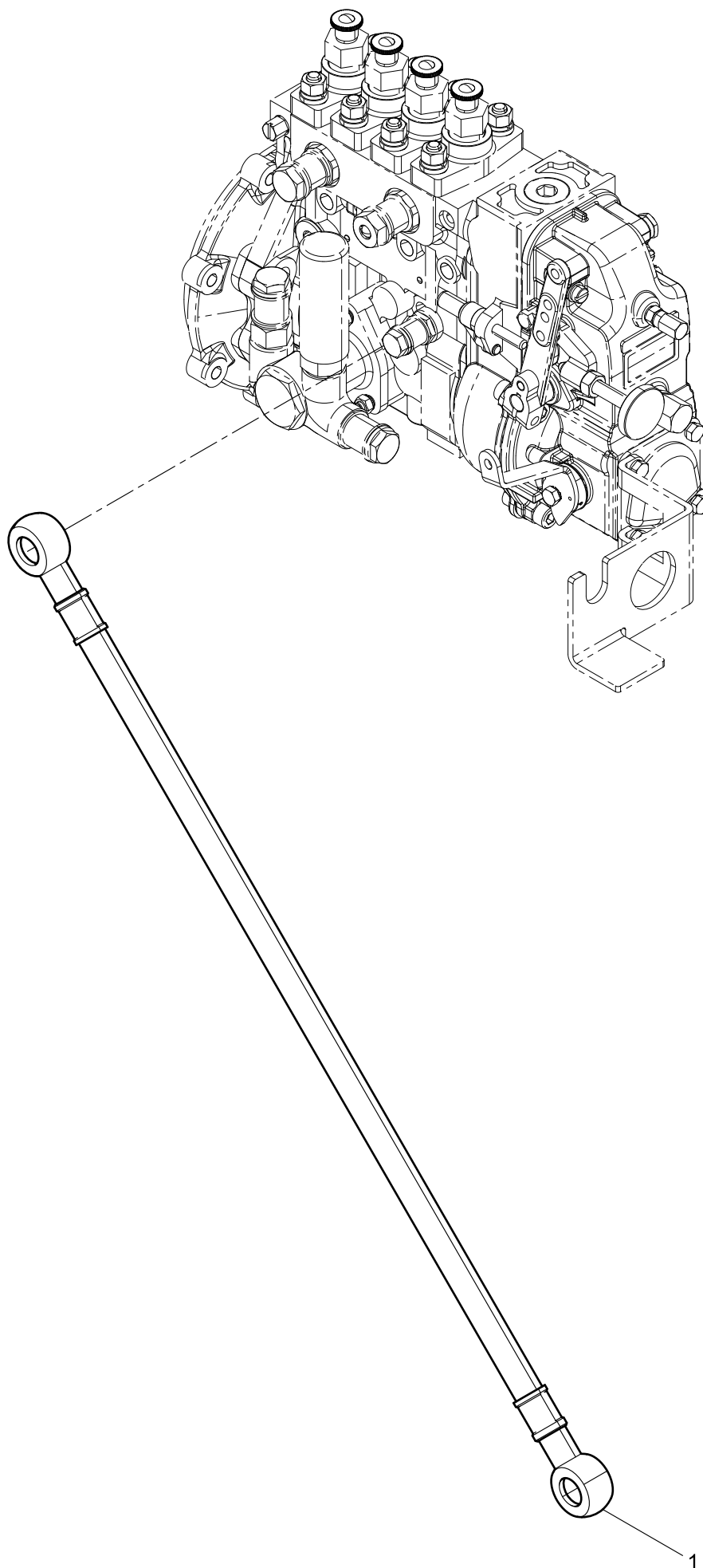



# 喷油器结合组(Fuel Injector Group)

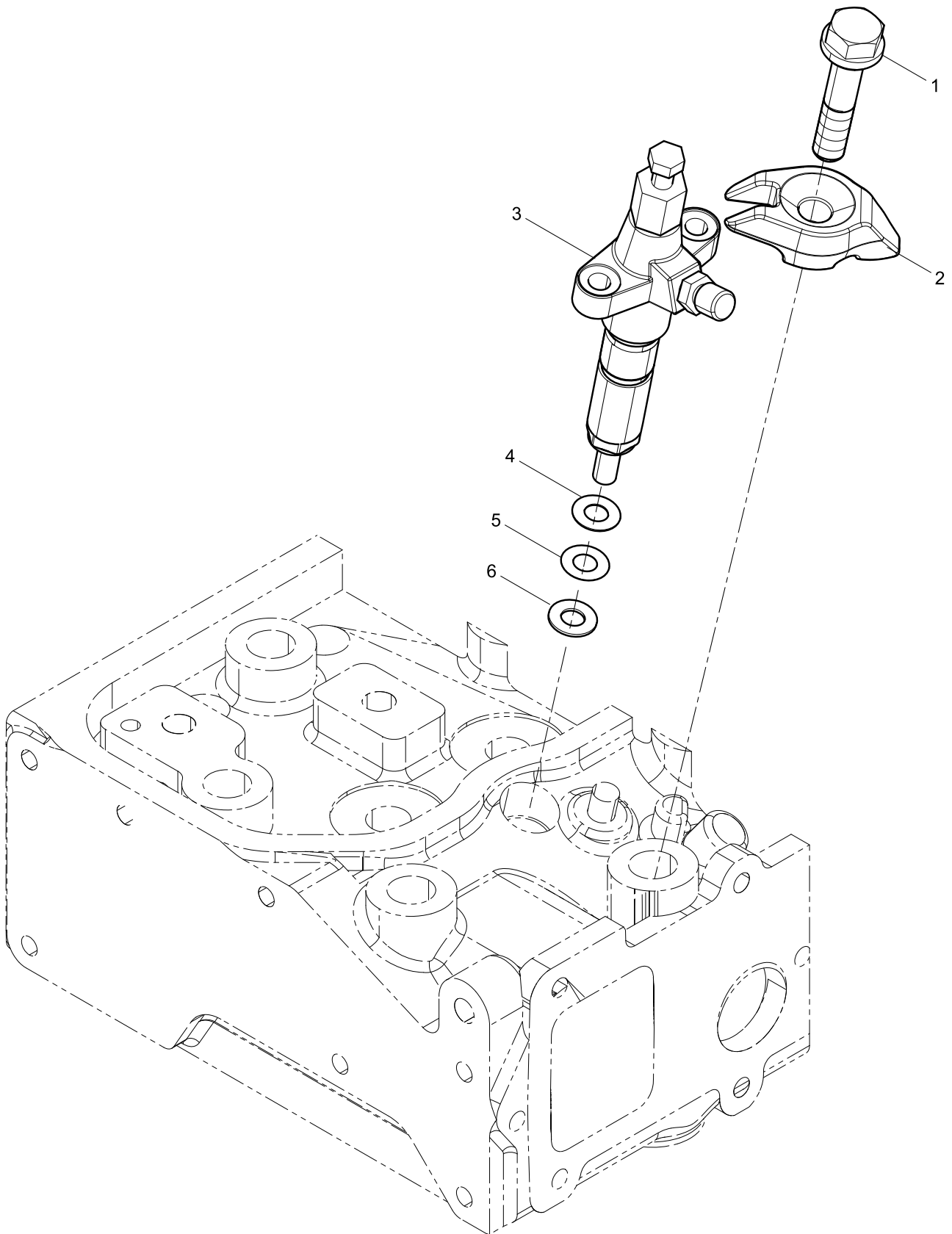





# 低压油管结合组(Low Pressure Fuel Pipe Group)

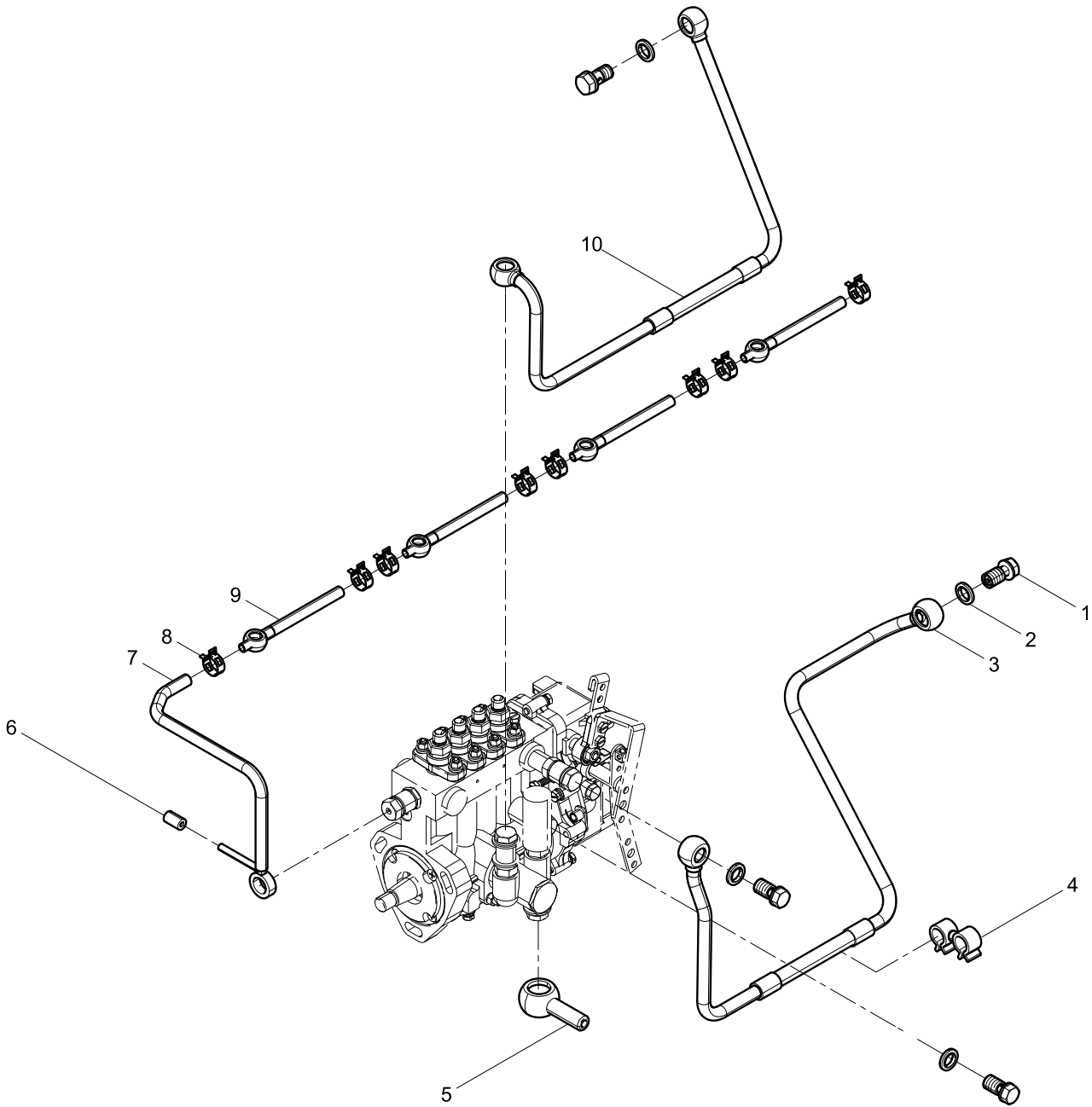

**低压油管结合组(Low Pressure Fuel Pipe Group)**

<b>图序号</b> <b>Pos.</b>	<b>件号</b> <b>Teile.Number</b>	<b>数量</b> <b>Amount</b>	<b>中文名称</b> <b>Denomination</b>	<b>英文名称</b> <b>Designation</b>
1	2020175	4	进油螺钉	Oil inlet screw
2	2ZHDQ-10	4	组合垫圈	Unit washer
3	1001561548	1	燃油进油管总成	Fuel-inlet Pipe Assembly
4	612600082743	2	管夹	Pipe Clamp
5	2120116	1	输油泵进油管接头	Delivery pump oil-inlet pipe joint
6	2120206	1	喷油器回油管堵塞	
7	2085070104	1	喷油器回油管组合	Injector Fuel-return Pipe Group
8	2B050013	8	环箍	
9	2085080133	3	喷油器回油管	Injector Fuel-return Pipe
10	1001561549	1	燃油进油管总成	Fuel-inlet Pipe Assembly

# 燃油滤清器结合组(Fuel Filter Group)

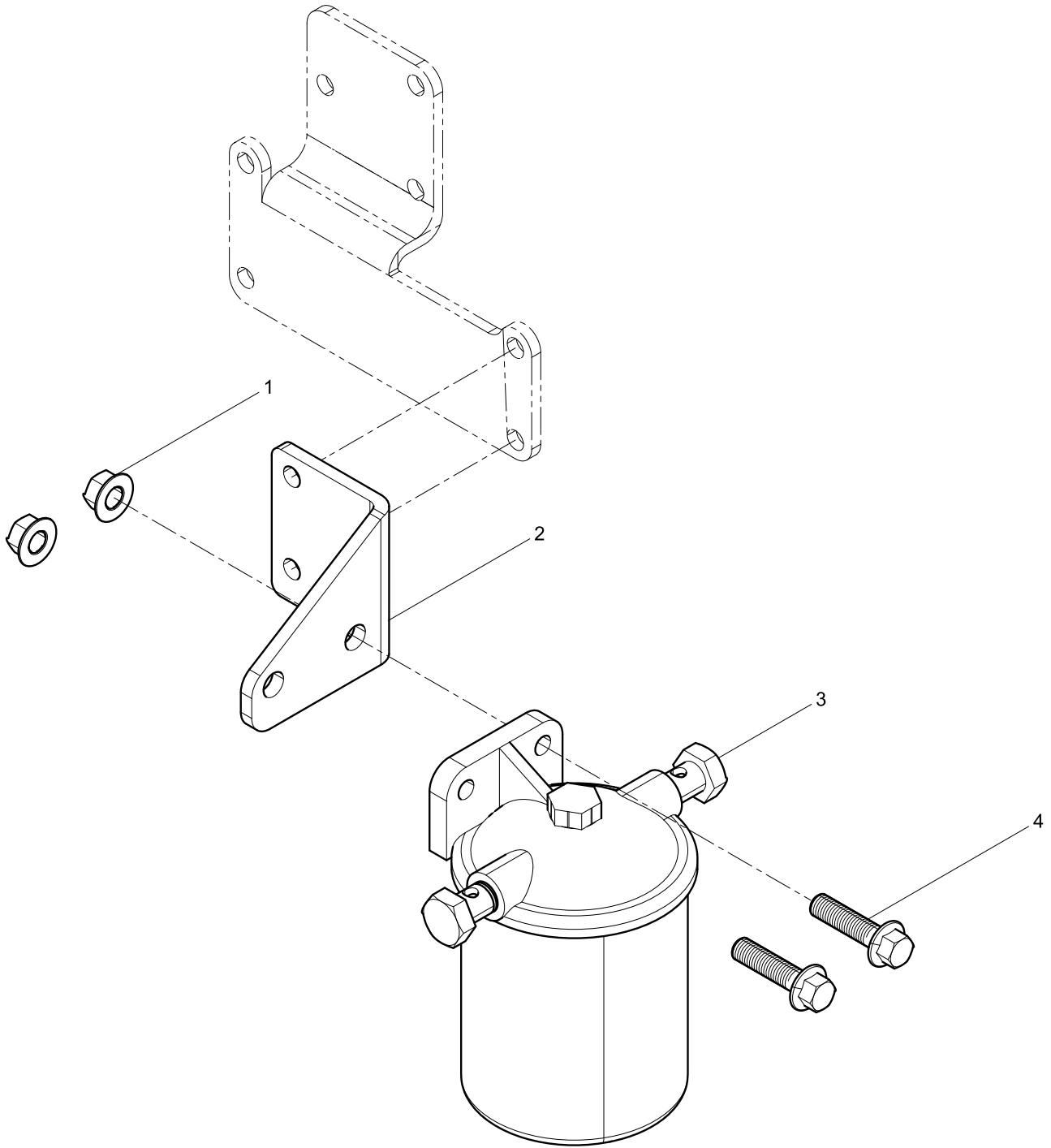

燃油滤清器结合组(Fuel Filter Group)

图序号 Pos.	件号 Teile.Number	数量 Amount	中文名称 Denomination	英文名称 Designation
1	41880410F	1	六角法兰面螺母	Hexagon Flange Nut
2	1001160198	1	燃油滤清器支架	Fuel Filter Bracket
3	1001540355	1	燃油滤清器总成	Fuel Filter Assembly
	1001538508	1	燃油滤清器滤芯	Fuel Filter Element
	1001016798	1	燃油滤清器座	Fuel Filter Seat
4	41901410F	2	六角法兰面螺栓	Hexagon Flange Bolt

高压油管结合组(High Pressure Fuel Pipe Group)

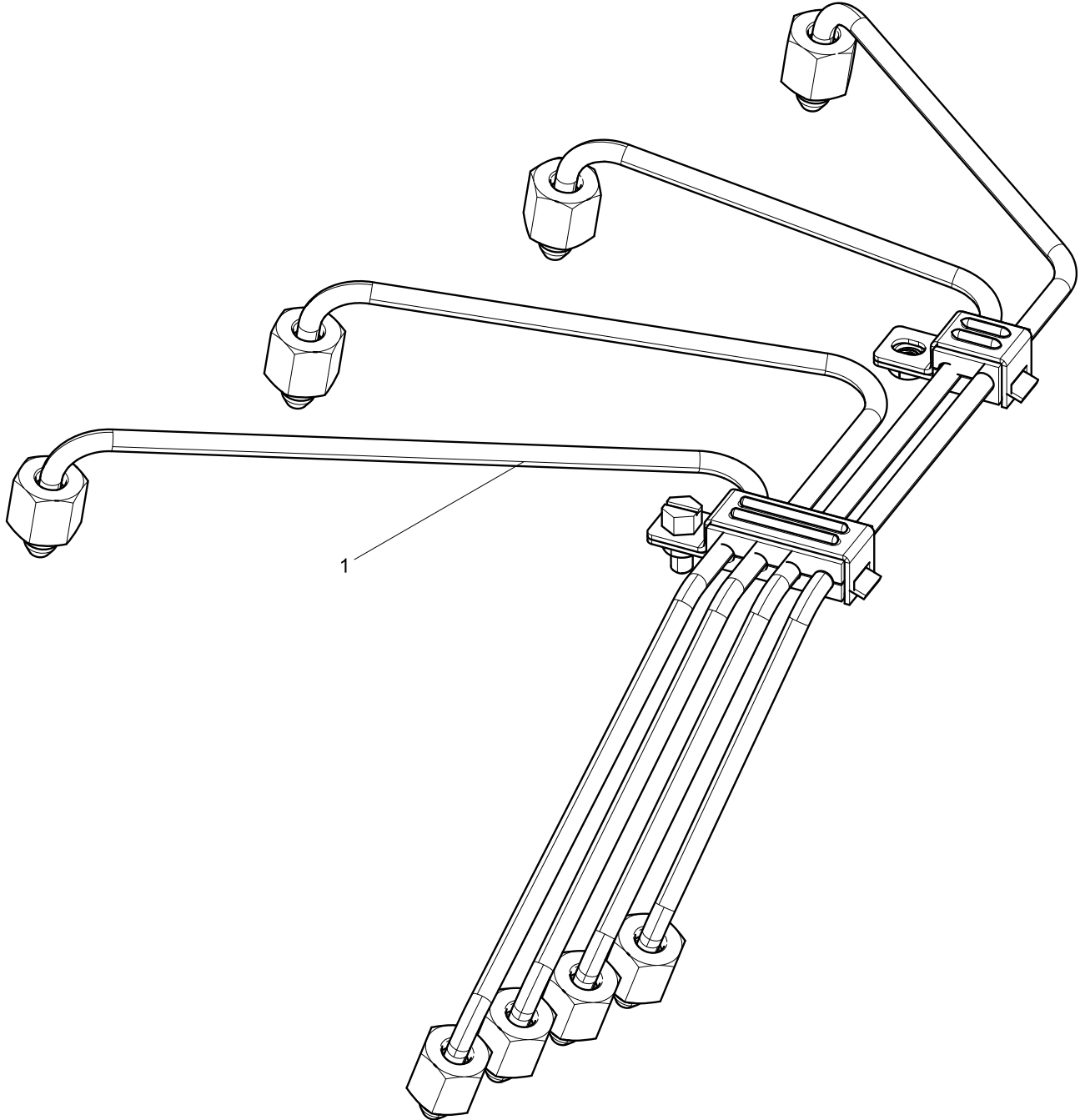



# 高压油管总成(High-pressure Fuel Pipe Assembly)

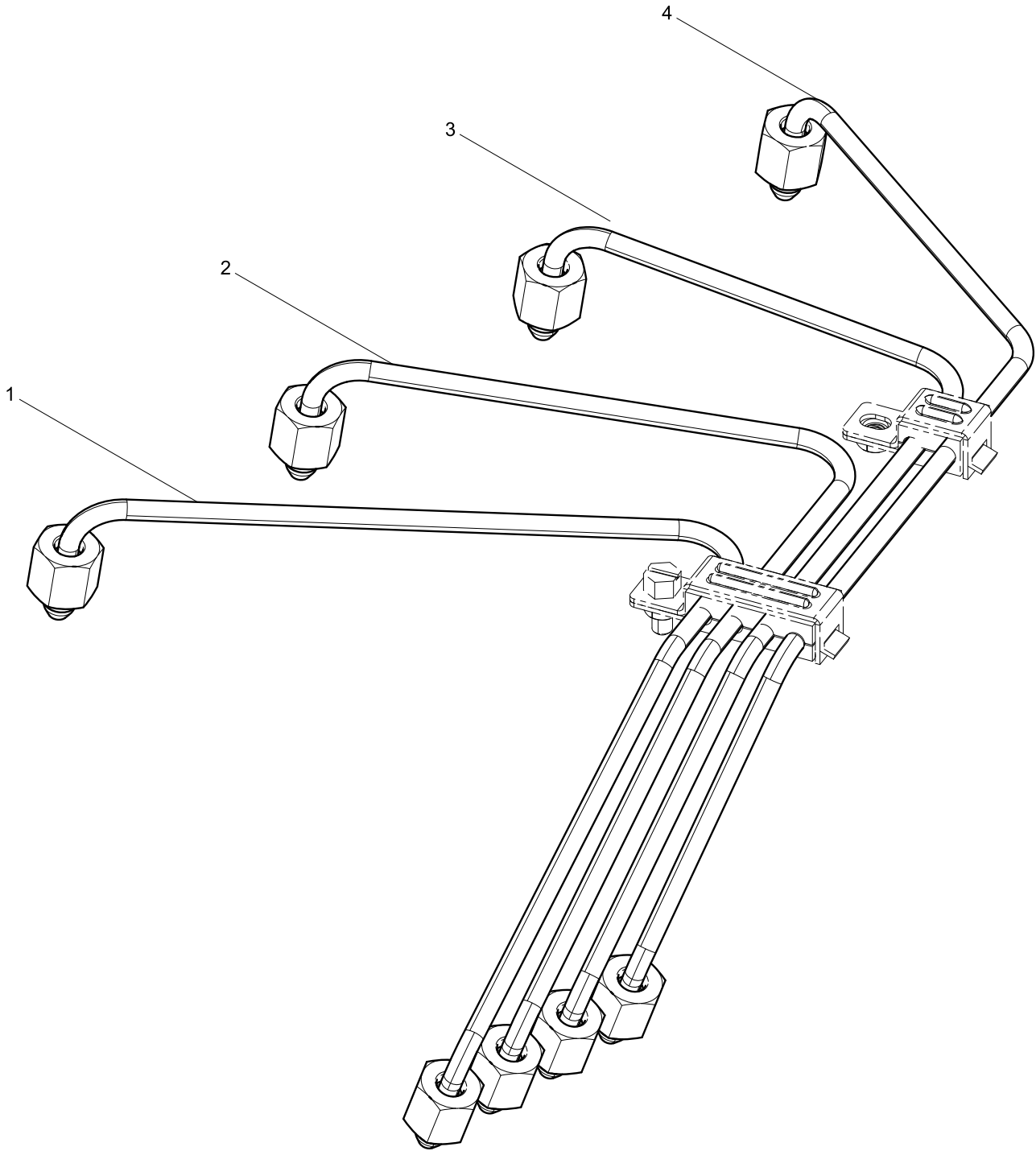

高压油管总成(High-pressure Fuel Pipe Assembly)

图序号 Pos.	件号 Teile.Number	数量 Amount	中文名称 Denomination	英文名称 Designation
1	1001223550	1	高压油管总成	High-pressure Fuel Pipe Assembly
2	1001223551	1	高压油管总成	High-pressure Fuel Pipe Assembly
3	1001223552	1	高压油管总成	High-pressure Fuel Pipe Assembly
4	1001223554	1	高压油管总成	High-pressure Fuel Pipe Assembly



# 进气管结合组(Intake Manifold Group)

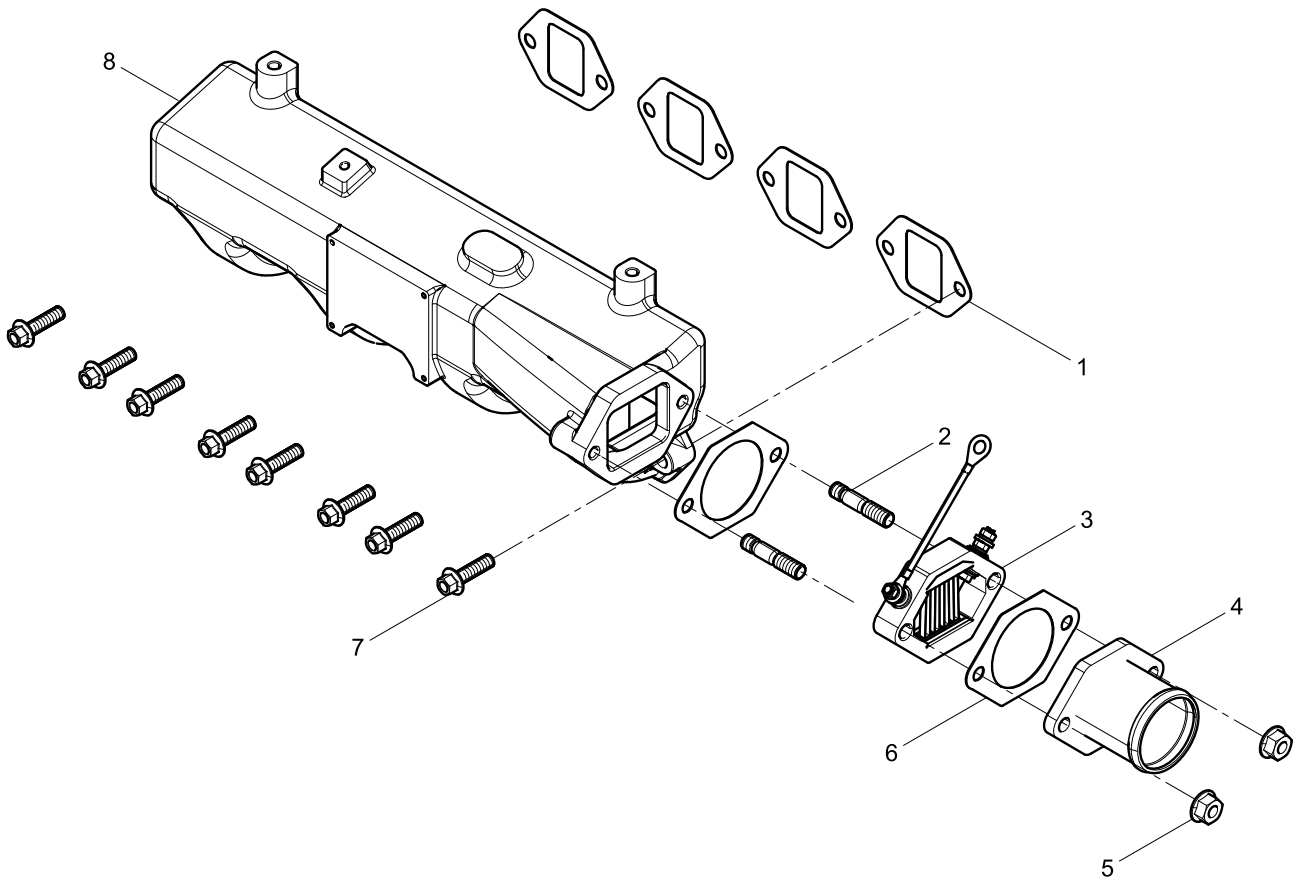

### 进气管结合组(Intake Manifold Group)

图序号 Pos.	件号 Teile.Number	数量 Amount	中文名称 Denomination	英文名称 Designation
1	2010020	4	进气管垫片	Intake Manifold Gasket
2	90011520051	2	双头螺柱	Double End Stud
3	2060361/1	1	加热器	Heater
4	2060417	1	进气管	Intake Manifold
5	41880208F	2	六角法兰面螺母	Hexagon Flange Nut
6	1001689536	2	垫片	Gasket
7	90011420015	8	六角法兰面螺栓	Hexagon Flange Bolt
8	1001541030	1	进气管	Intake Manifold

空气滤清器结合组(Air Filter Group)

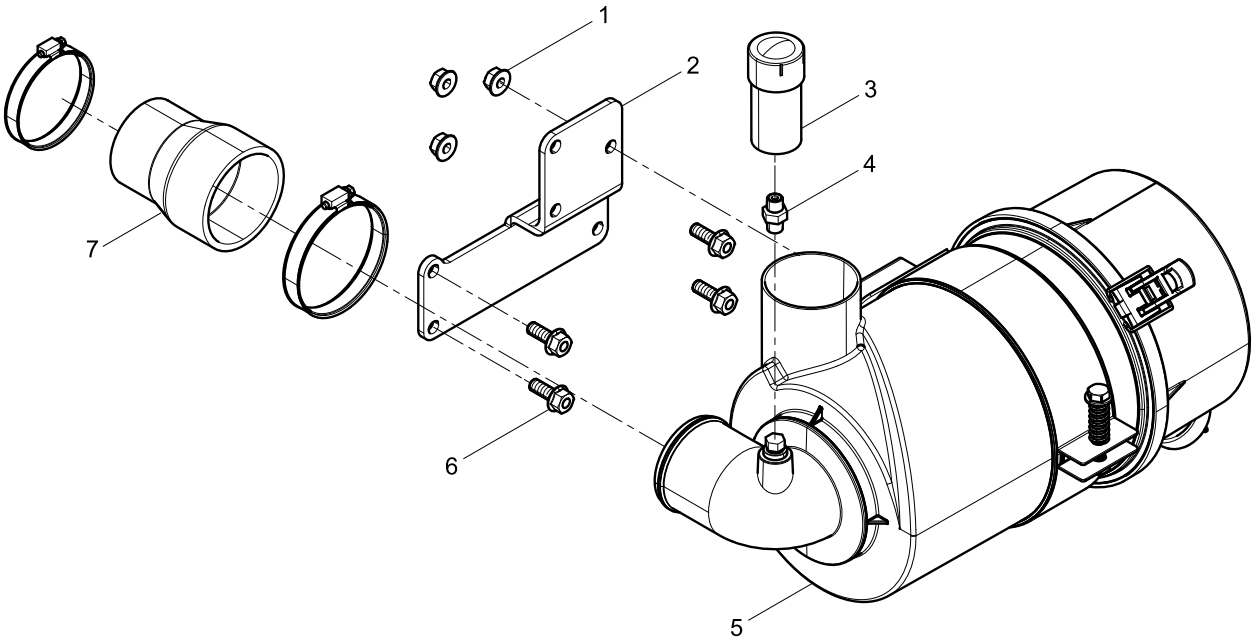

**空气滤清器结合组(Air Filter Group)**

图序号 Pos.	件号 Teile.Number	数量 Amount	中文名称 Denomination	英文名称 Designation
1	41880308F	3	六角法兰面螺母	Hexagon Flange Nut
2	1001916972	1	空滤器支架	Air Filter Bracket
3	1000644232	1	进气阻力报警器	Intake Resistance Alarm
4	612600115282	1	中间接头	Transition joint
5	1001548273	1	空气滤清器	Air Filter
	1001548274	1	空气滤清器壳体	Air Filter Housing
	1000940409	1	空气滤清器芯	Air Filter Element
6	41901306F	3	六角法兰面螺栓	Hexagon Flange Bolt
7	1001916983	1	进气接管	Intake Connecting Pipe

# 排气管结合组(Exhaust Manifold Group)

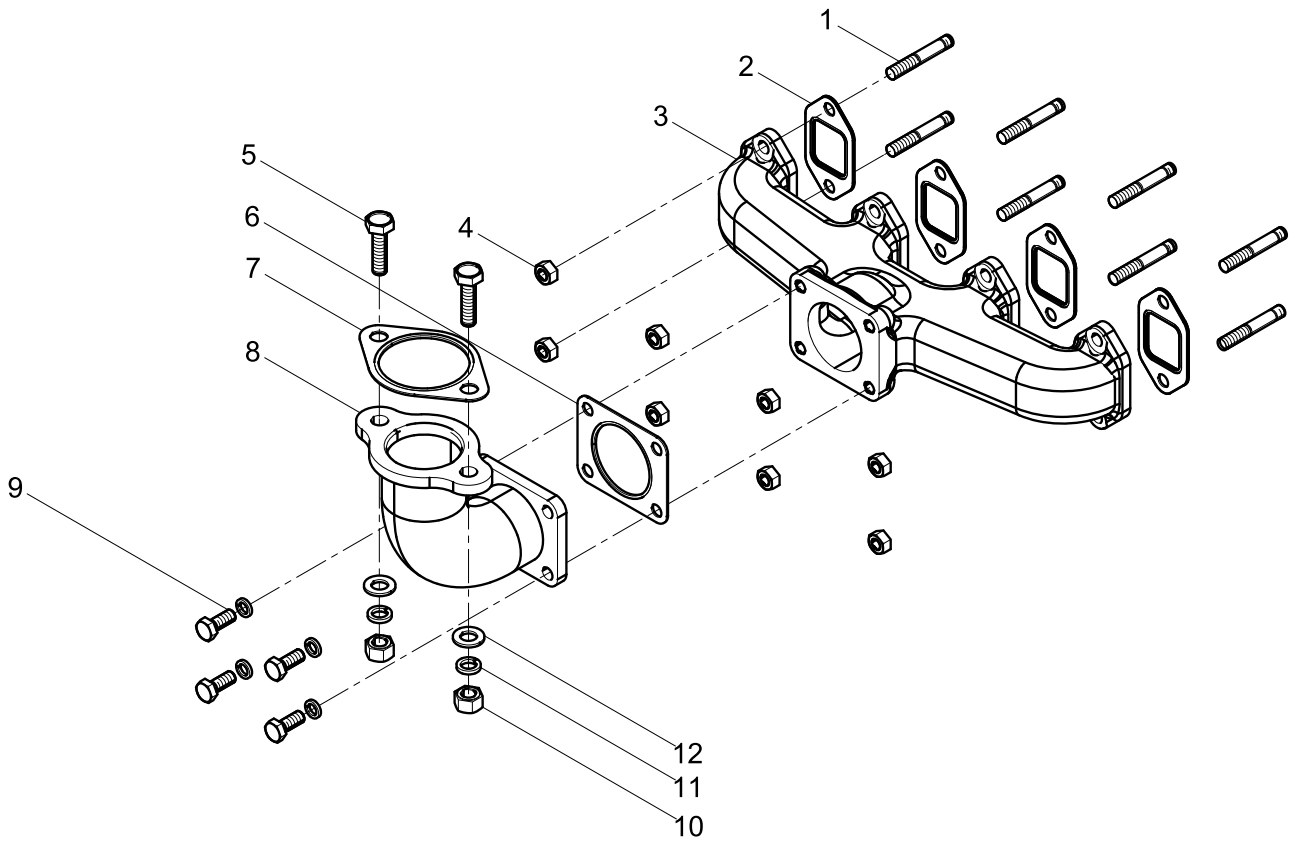

**排气管结合组(Exhaust Manifold Group)**

图序号 Pos.	件号 Teile.Number	数量 Amount	中文名称 Denomination	英文名称 Designation
1	90003813443	8	双头螺柱	Double End Stud
2	2060008	4	排气支管垫片	Exhaust Manifold gasket
3	1001296285	1	排气管隔热罩总成	Exhaust Manifold Heat Shield Assembly
	1001218178	1	排气管隔热罩	Exhaust Manifold Heat Shield
	1001296284	1	排气歧管	Exhaust Manifold
4	2BLM-M8	12	六角螺帽	Hexagon Screw cap
5	X6231.633W	2	排气管螺栓	Exhaust Manifold Bolt
6	1000757316	1	增压器垫片	Turbocharger washer
7	1001251923	1	排气管衬垫	Exhasut Manifold Gasket
8	2085110101	1	排气接管	ExhaustConnecting Pipe
9	2102110168	4	双头螺柱	Double End Stud
10	90003871305	2	1型六角螺母	Hexagon Nuts, Style 1
11	90003931122	2	弹簧垫圈	Spring Washer
12	B291.15	1	堵盖	Plug
	1000791991	1	膨胀管	Expansion Pipe

张紧轮及皮带结合组(Tensioner And Belt Group)

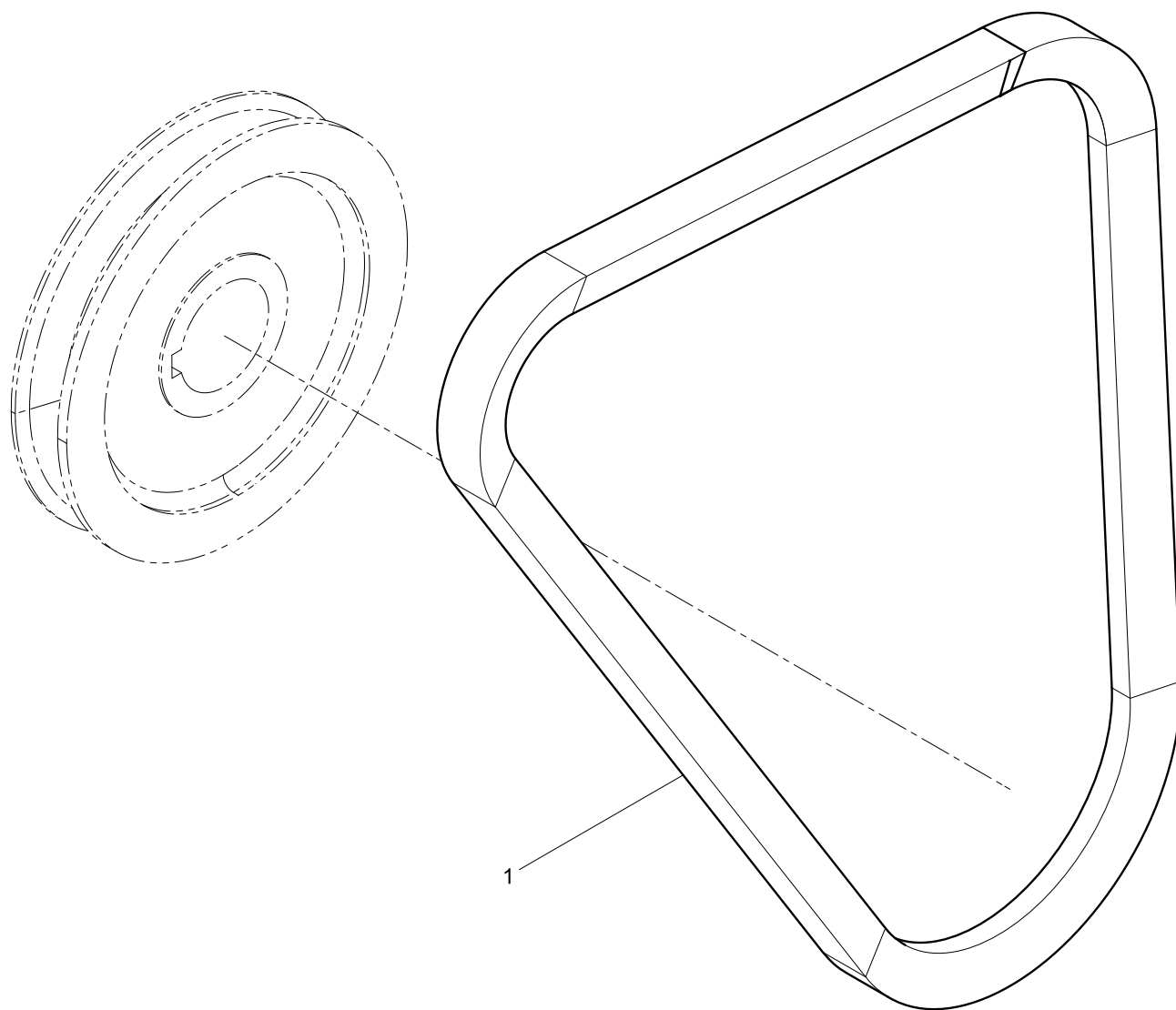

张紧轮及皮带结合组(Tensioner And Belt Group)

图序号 Pos.	件号 Teile.Number	数量 Amount	中文名称 Denomination	英文名称 Designation
1	1002080618	1	多楔带	Poly V Belt



# 起动机结合组(Starter Motor Group)

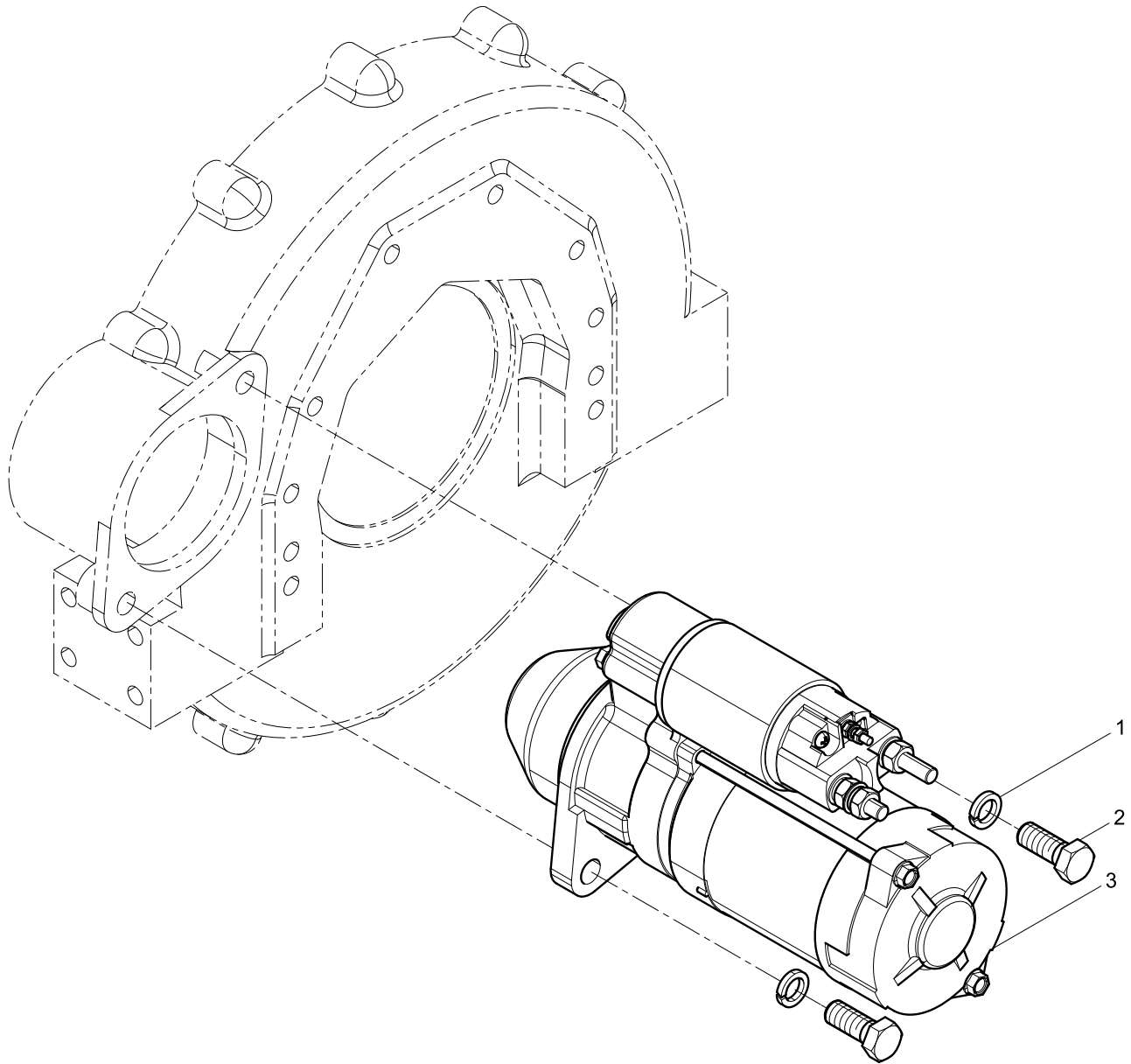

**起动机结合组(Starter Motor Group)**

图序号 Pos.	件号 Teile.Number	数量 Amount	中文名称 Denomination	英文名称 Designation
1	1001538960	1	起动机	Starter Motor
2	2BTDQ-D12	2	弹簧垫圈	Spring Washer
3	2BLS-M12X30/8.8	2	六角螺栓	Hexagon head bolt

# 发动机支架结合组(Engine Bracket Group)

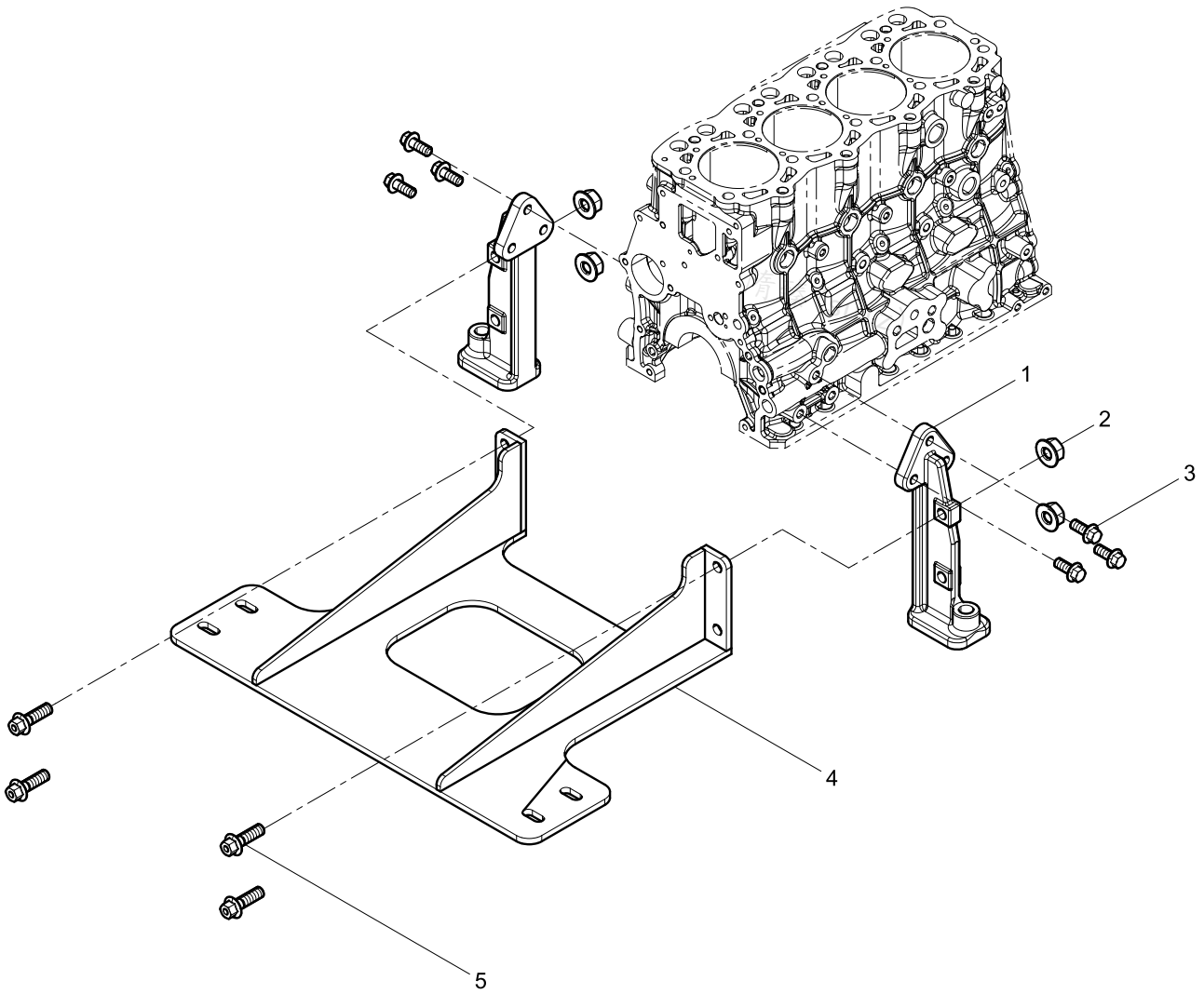

**发动机支架结合组(Engine Bracket Group)**

图序号 Pos.	件号 Teile.Number	数量 Amount	中文名称 Denomination	英文名称 Designation
1	1001058162	2	发动机支架	Engine Bracket
2	90012290003	4	六角法兰面螺母	Hexagon Flange Nut
3	41901408F	6	六角法兰面螺栓	Hexagon Flange Bolt
4	1001071616	1	膨胀水箱支架	Expansion Tank Bracket
5	9000000045	4	六角法兰面螺栓	Hexagon Flange Bolt

主机外围附件支撑结合组(Engine Peripheral Device Support Group)

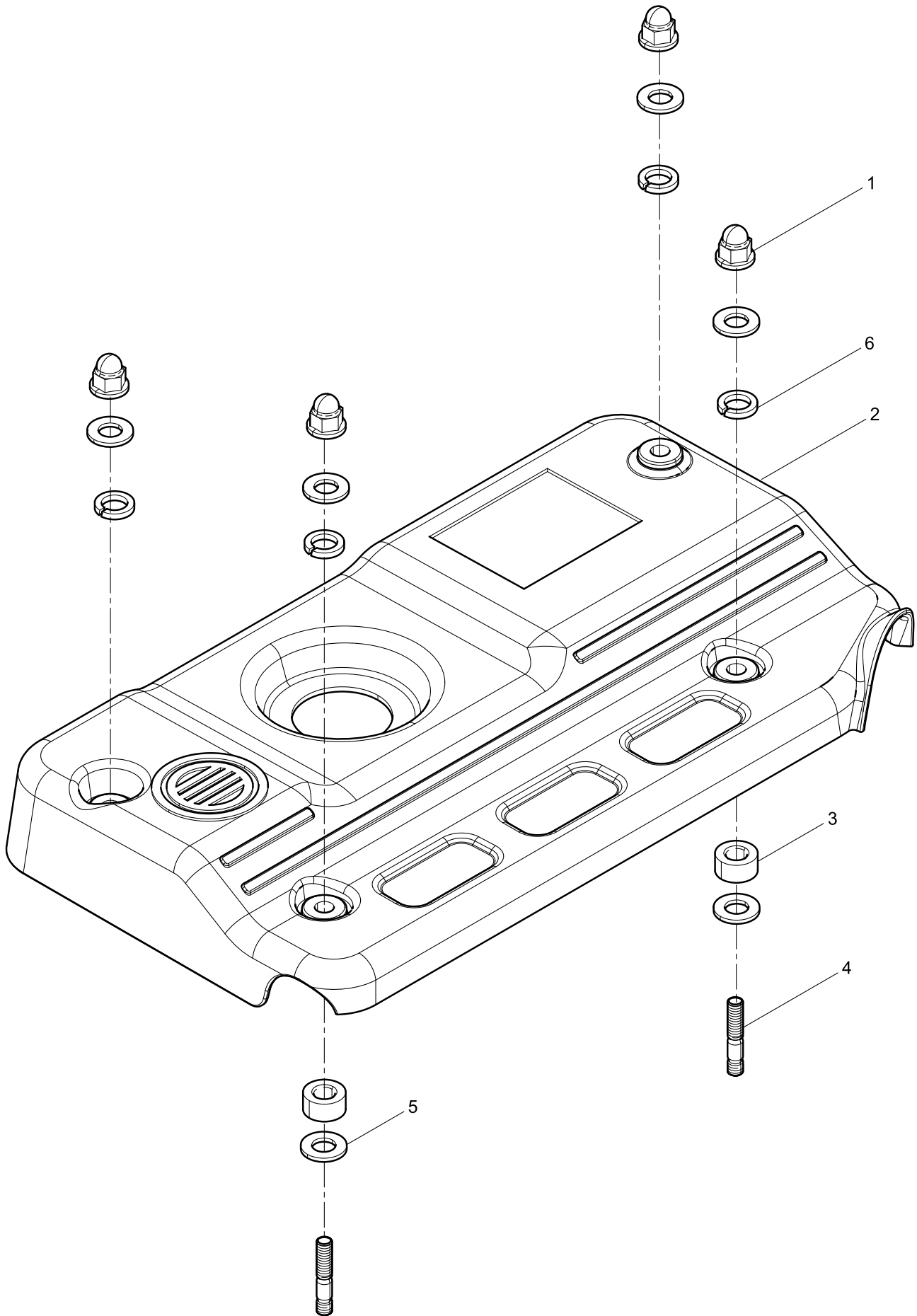

### 主机外围附件支撑结合组(Engine Peripheral Device Support Group)

图序号 Pos.	件号 Teile.Number	数量 Amount	中文名称 Denomination	英文名称 Designation
1	2090040143	4	盖型螺母	Acorn Nut
2	1001538966	1	隔音罩	Sound Insulation Cover
3	2251088	2	垫块	Pad
4	90003813447	2	双头螺柱	Double End Stud
5	90014040007	8	平垫圈	Plain Washer
6	90003931102	4	弹簧垫圈	Spring Washer

随机备件结合组(Spare Parts Attached to Engine Group)

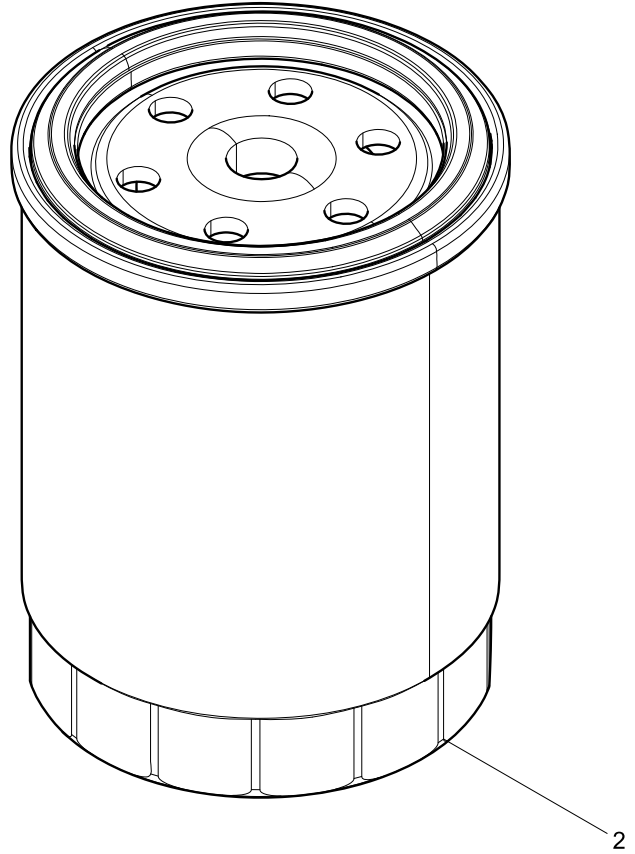
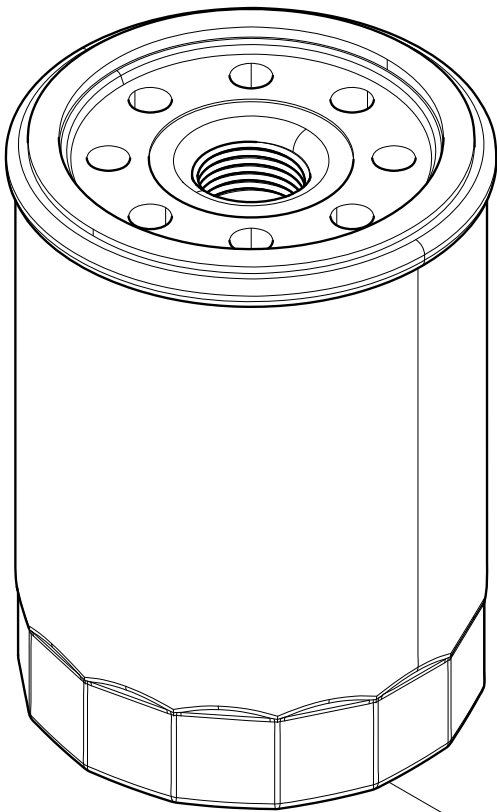
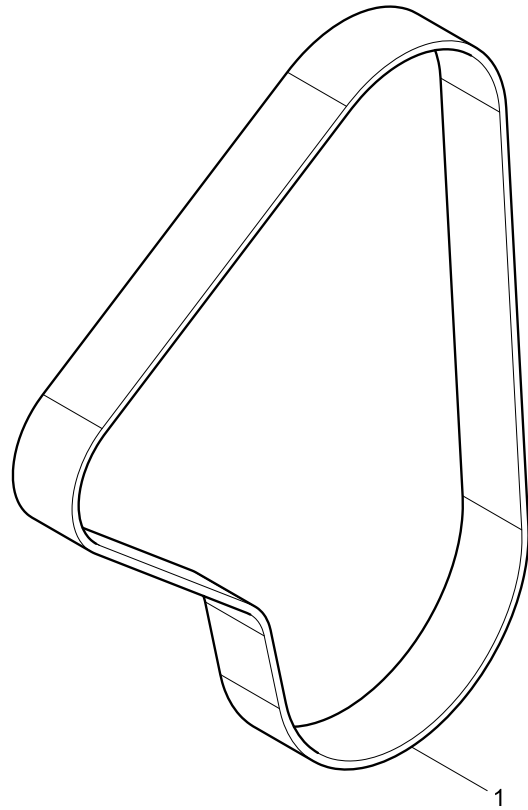

### 随机备件结合组(Spare Parts Attached to Engine Group)

图序号 Pos.	件号 Teile.Number	数量 Amount	中文名称 Denomination	英文名称 Designation
1	1002080618	1	多楔带	Poly V Belt
2	1001538508	1	燃油滤清器滤芯	Fuel Filter Element
3	1001910416	1	机油滤清器滤芯	Oil Filter Element



# 发电机结合组(Alternator Group)

